



YFM600 Grizzly

Service Manual

358+1

LIT-11616-FW-00



YAMAHA

YFM600FWAL

YFM600FWALC

**SUPPLEMENTARY
SERVICE MANUAL**

FOREWORD

This Supplementary Service Manual has been prepared to introduce new service and data for the YFM600FWAL/YFM600FWALC. For complete service information procedures it is necessary to use this Supplementary Service Manual together with the following manual.

YFM600FWAK SERVICE MANUAL: LIT-11616-11-02 (4WV-F8197-E0)
YFM600FWACK SUPPLEMENTARY SERVICE MANUAL: LIT-11616-11-21 (4WV-F8197-E1)

**YFM600FWAL/YFM600FWALC
SUPPLEMENTARY
SERVICE MANUAL**
©1998 by Yamaha Motor Corporation, U.S.A.
First Edition, September 1998
All rights reserved. Any reproduction or
unauthorized use without the written
permission of Yamaha Motor Corporation, U.S.A.
is expressly prohibited.
Printed in U.S.A.
LIT-11616-12-37

NOTICE

This manual was produced by the Yamaha Motor Company primarily for use by Yamaha dealers and their qualified mechanics. It is not possible to include all the knowledge of a mechanic in one manual, so it is assumed that anyone who uses this book to perform maintenance and repairs on Yamaha machine has a basic understanding of the mechanical ideas and the procedures of machine repair. Repairs attempted by anyone without this knowledge are likely to render the machine unsafe and unfit for use.

Yamaha Motor Company, Ltd. is continually striving to improve all its models. Modifications and significant changes in specifications or procedures will be forwarded to all authorized Yamaha dealers and will appear in future editions of this manual where applicable.

NOTE: _____
Designs and specifications are subject to change without notice.

IMPORTANT INFORMATION

Particularly important information is distinguished in this manual by the following notations.



The Safety Alert Symbol means ATTENTION! BECOME ALERT! YOUR SAFETY IS INVOLVED!

WARNING

Failure to follow WARNING instructions could result in severe injury or death to the machine operator, a bystander or a person inspecting or repairing the machine.

CAUTION:

A CAUTION indicates special precautions that must be taken to avoid damage to the machine.

NOTE: A NOTE provides key information to make procedures easier or clearer.

HOW TO USE THIS MANUAL

MANUAL ORGANIZATION

This manual consists of chapters for the main categories of subjects. (See "Illustrated symbols")

1st title ①: This is the title of the chapter with its symbol in the upper right corner of each page.

2nd title ②: This title indicates the section of the chapter and only appears on the first page of each section. It is located in the upper left corner of the page.

3rd title ③: This title indicates a sub-section that is followed by step-by-step procedures accompanied by corresponding illustrations.

EXPLODED DIAGRAMS

To help identify parts and clarify procedure steps, there are exploded diagrams at the start of each removal and disassembly section.

1. An easy-to-see exploded diagram ④ is provided for removal and disassembly jobs.
2. Numbers ⑤ are given in the order of the jobs in the exploded diagram. A number that is enclosed by a circle indicates a disassembly step.
3. An explanation of jobs and notes is presented in an easy-to-read way by the use of symbol marks ⑥. The meanings of the symbol marks are given on the next page.
4. A job instruction chart ⑦ accompanies the exploded diagram, providing the order of jobs, names of parts, notes in jobs, etc.
5. For jobs requiring more information, the step-by-step format supplements ⑧ are given in addition to the exploded diagram and the job instruction chart.

②

①

CLUTCH

CLUTCH ENG

CLUTCH ENG

④

⑤

⑦

③

⑧

⑥

Order	Job name/Part name	Qty	Remarks
	Clutch removal		Remove the parts in the order below. Refer to "PRIMARY AND SECONDARY SHEAVES"
1	Cover	1	
2	Clutch housing assembly	1	
3	Gasket / dowel pin	1	Refer to "CLUTCH REMOVAL / INSTALLATION"
4	One way clutch bearing	1	
5	Nut	1	
6	Clutch carrier assembly	1	
7	Cap	1	

For installation, reverse the removal procedure.

CLUTCH REMOVAL

1 Remove

- Clutch housing assembly
- Gasket
- Dowel pins

NOTE

Working in clockwise pattern, loosen each bolt 1/4 of turn. Remove them after all of them are loosened.

2 Straighten

- Flashed portion of the nut ⑥

3 Remove

- Nut ⑥

NOTE

Use a clutch holding tool ⑧ to hold the clutch carrier assembly.

Clutch holding tool
P/N YM-510A2 90990-0408

CLUTCH INSPECTION

1 Inspect

- Clutch housing ⑥
- Heat damage/wear/damage - Replace
- One way clutch bearing ⑥
- Chasing gear/damage - Replace

NOTE

- Replace the one way clutch assembly and clutch housing as a set
- The one way clutch bearing must be installed with the flange side facing in

.....

Clutch operation

Install the one way clutch bearing and clutch carrier assembly to the clutch housing and hold the clutch carrier assembly.

When turning the clutch housing clockwise ⑥, the clutch housing should turn freely.

If not, the one way clutch assembly is faulty.

Replace it.

When turning the clutch housing counter-clockwise ⑥, the clutch housing and crankshaft should be engaged.

If not, the one way clutch assembly is faulty.





















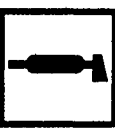

Replace it.

.....

ILLUSTRATED SYMBOLS

Illustrated symbols ① to ⑨ are printed on the top right of each page and indicate the subject of each chapter.

- ① General information
- ② Specifications
- ③ Periodic inspections and adjustments
- ④ Engine
- ⑤ Carburetion
- ⑥ Drive train
- ⑦ Chassis
- ⑧ Electrical
- ⑨ Troubleshooting

① GEN INFO 	② SPEC 	
③ INSP ADJ 	④ ENG 	
⑤ CARB 	⑥ DRIV 	
⑦ CHAS 	⑧ ELEC 	
⑨ TRBL SHTG ?	⑩ 	
⑪ 	⑫ 	
⑬ 	⑭ 	
⑮ 	⑯ 	⑰ 
⑱ 	⑲ 	⑳ 
㉑ 	㉒ 	㉓ 
㉔ 	㉕ New	

Illustrated symbols ⑩ to ⑰ are used to identify the specifications appearing in the text.

- ⑩ Can be serviced with engine mounted
- ⑪ Filling fluid
- ⑫ Lubricant
- ⑬ Special tool
- ⑭ Torque
- ⑮ Wear limit, clearance
- ⑯ Engine speed
- ⑰ Ω, V, A

Illustrated symbols ⑱ to ㉓ in the exploded diagrams indicate the types of lubricants and lubrication points.

- ⑱ Apply engine oil
- ⑲ Apply gear oil
- ⑳ Apply molybdenum disulfide oil
- ㉑ Apply wheel bearing grease
- ㉒ Apply lightweight lithium-soap base grease
- ㉓ Apply molybdenum disulfide grease

Illustrated symbols ㉔ to ㉕ in the exploded diagrams indicate where to apply a locking agent ㉔ and when to install a new part ㉕.

- ㉔ Apply the locking agent (LOCTITE®)
- ㉕ Replace

CONTENTS

SPECIFICATIONS	1
GENERAL SPECIFICATIONS.....	1
MAINTENANCE SPECIFICATIONS.....	2
ENGINE.....	2
CHASSIS.....	5
ELECTRICAL.....	7
LUBRICATION DIAGRAMS.....	8
CABLE ROUTING.....	9



SPECIFICATIONS

GENERAL SPECIFICATIONS

Item	Standard
Model code:	5GT1 (USA), 5GT2 (California), 5GT3 (CDN), 5GT4 (Europe), 5GT5 (Oceania)
Dimensions:	
Overall length	2,068 mm (81.4 in)
Overall width	1,161 mm (45.7 in)
Overall height	1,215 mm (47.8 in)
Seat height	865 mm (34.1 in)
Wheelbase	1,254 mm (49.4 in)
Minimum ground clearance	175 mm (6.9 in)
Minimum turning radius	3,100 mm (122 in)
Basic weight:	
With oil and full fuel tank	289 kg (637 lb) (Except for Europe and Oceania) 290 kg (639 lb) (For Europe and Oceania)
Engine:	
Engine type	Air-cooled 4-stroke, SOHC
Cylinder arrangement	Forward-inclined single cylinder
Displacement	595 cm ³ (36.31 cu in)
Bore × stroke	95 × 84 mm (3.74 × 3.31 in)
Compression ratio	8.5 :1
Compression pressure (STD)	700 kPa (7 kgf/cm ² , 101.5 psi) 600 rpm
Starting system	Electric and recoil starter
Spark plug:	
Type	DP8EA-9 (Except for CDN and Europe) DPR8EA-9 (For CDN and Europe)
Manufacturer	NGK
Spark plug gap	0.8 ~ 0.9 mm (0.03 ~ 0.04 in)
Tire:	
Type	Tubeless
Size	front AT25×8-12 rear AT25×10-12
Manufacturer	front DUNLOP rear DUNLOP
Type	front KT404A rear KT405G
Tire pressure (cold tire):	
Off-road riding	front 22 ~ 25 kPa (0.22 ~ 0.25 kg/cm ² , 3.2 ~ 3.6 psi) rear 22 ~ 25 kPa (0.22 ~ 0.25 kg/cm ² , 3.2 ~ 3.6 psi)
Electrical:	
Ignition system	C.D.I.
Generator system	CDI magneto
Battery type	YTX20L-BS
Battery capacity	12 V 18 AH

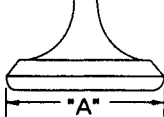
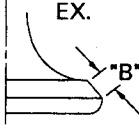
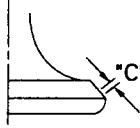
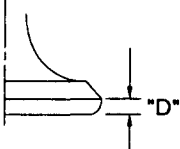

MAINTENANCE SPECIFICATIONS
ENGINE

Item		Standard	Limit
Rocker arm/rocker arm shaft:			
Shaft outside diameter		11.985 ~ 11.991 mm (0.4719 ~ 0.4721 in)	----
Arm inside diameter		12.000 ~ 12.018 mm (0.4724 ~ 0.4731 in)	----
Arm-to-shaft clearance		0.009 ~ 0.033 mm (0.0004 ~ 0.0013 in)	----
Valve, valve seat, valve guide:			
Valve clearance(cold)	IN	0.05 ~ 0.10 mm (0.002 ~ 0.004 in)	----
	EX	0.12~0.17 mm (0.005~0.007 in)	----
Valve dimensions:			
			
Head Dia	Face Width	Seat Width	Margin Thickness
"A" head diameter	IN	36.9 ~ 37.1 mm (1.453 ~ 1.461 in)	----
	EX	31.9 ~ 32.1 mm (1.256 ~ 1.264 in)	----
"B" face width	IN	2.26 mm (0.089 in)	----
	EX	2.26 mm (0.089 in)	----
"C" seat width	IN	1.0 ~ 1.2 mm (0.039 ~ 0.047 in)	1.6 mm (0.063 in)
	EX	1.0 ~ 1.2 mm (0.039 ~ 0.047 in)	1.6 mm (0.063 in)
"D" margin thickness	IN	1.0 ~ 1.4 mm (0.039 ~ 0.055 in)	1.2 mm (0.047 in)
	EX	0.8 ~ 1.2 mm (0.031 ~ 0.047 in)	1.0 mm (0.039 in)
Stem outside diameter	IN	6.975 ~ 6.990 mm (0.2746 ~ 0.2752 in)	----
	EX	6.955 ~ 6.970 mm (0.2738 ~ 0.2744 in)	----
Guide inside diameter	IN	7.000 ~ 7.012 mm (0.2756 ~ 0.2761 in)	----
	EX	7.000 ~ 7.012 mm (0.2756 ~ 0.2761 in)	----
Stem-to-guide clearance	IN	0.010 ~ 0.037 mm (0.0004 ~ 0.0015 in)	0.08 mm (0.003 in)
	EX	0.030 ~ 0.057 mm (0.0012 ~ 0.0022 in)	0.10 mm (0.004 in)

MAINTENANCE SPECIFICATIONS

SPEC

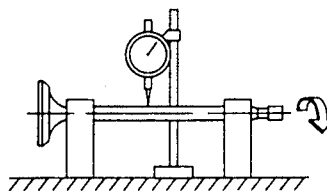
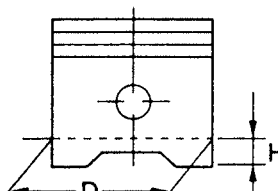

Item	Standard	Limit
Stem runout limit 	----	0.01 mm (0.0004 in)
Valve seat width IN EX	1.1 mm (0.043 in) 1.1 mm (0.043 in)	---- ----
Piston: Piston to cylinder clearance Piston size "D" 	0.045 ~ 0.065 mm (0.0018 ~ 0.0026 in) 94.915 ~ 94.965 mm (3.737 ~ 3.739 in)	0.15 mm (0.0059 in) ----
Measuring point "H" Piston off-set Piston off-set direction Piston pin bore inside diameter Piston pin outside diameter	5 mm (0.20 in) 2 mm (0.08 in) inside 22.004 ~ 22.015 mm (0.8663 ~ 0.8661 in) 21.991 ~ 22.000 mm (0.8658 ~ 0.8661 in)	---- ---- ---- ---- ----
Automatic centrifugal clutch: Clutch shoe thickness Clutch shoe spring free length Clutch-in revolution Clutch-stall revolution	1.5 mm (0.06 in) 21.6 mm (0.85 in) 1,900 r/min 2,800 r/min	1.0 mm (0.04 in) ---- ---- ----
Transmission: Main axle deflection limit Drive axle deflection limit	---- ----	0.06 mm (0.0024 in) 0.06 mm (0.0024 in)
Carburetor: I. D. mark Main jet (M.J) Main air jet (M.A.J) Jet needle (J.N) Needle jet (N.J) Pilot air jet (P.A.J.1)	4WV 00 (Except for California) 4WV 10 (For California) #145 (Except for California) #143.8 (For California) 0.6 6HH23-94-3 (Except for California) 6HH23-94-1 (For California) Y-0M (#782) 0.7	---- ---- ---- ---- ---- ----

MAINTENANCE SPECIFICATIONS

SPEC



Item	Standard	Limit
Pilot air jet (P.A.J.2)	1.0	----
Pilot outlet (P.O)	1.1	----
Pilot jet (P.J)	#42.5	----
Bypass 1 (B.P.1)	1.0	----
Bypass 2 (B.P.2)	0.8	----
Bypass 3 (B.P.3)	0.8	----
Pilot screw (P.S)	3 1/2	----
Valve seat size (V.S)	2.8	----
Starter jet (G.S.1)	#100	----
Starter jet (G.S.2)	2.0	----
Throttle valve size (Th.V)	#110	----
Float height (F.H)	14.7 mm (0.58 in)	----
Fuel level (F.L)	1.5 mm (0.06 in)	----
Engine idle speed	1,350 ~ 1,450 r/min	----
Intake vacuum	38.7 ~ 41.3 kPa (290 ~ 310 mmHg, 11.4281 ~ 12.1959 inHg)	----
Lubrication system:		
Oil filter type	Paper type	----
Oil pump type	Trochoid type	----
Tip clearance "A" or "B"	0.09 ~ 0.15 mm (0.004 ~ 0.006 in)	0.23 mm (0.009 in)
Side clearance	0.03 ~ 0.08 mm (0.001 ~ 0.003 in)	0.15 mm (0.006 in)
Bypass valve setting pressure	40 ~ 80 kPa (0.4 ~ 0.8 kg/cm ² , 5.69 ~ 11.38 psi)	----
Relief valve operating pressure	350 ~ 450 kPa (3.5 ~ 4.5 kg/cm ² , 49.8 ~ 64.0 psi)	----
Oil pressure (hot)	20 kPa (0.2 kgf/cm ² , 2.9 psi) 1,400 rpm	----
Pressure check location	COVER, ELEMENT	

MAINTENANCE SPECIFICATIONS

SPEC



CHASSIS

Item	Standard	Limit
Front suspension:		
Shock absorber travel	151 mm (5.94 in)	----
Fork spring free length	396 mm (15.6 in)	----
Fitting length	339 mm (13.35 in)	----
Spring rate (K1)	1 N/mm (1 kg/mm, 56.00 lb/in)	----
Optional spring	No	----
Rear suspension:		
Shock absorber travel	122.5 mm (4.82 in)	----
Spring free length	326.2 mm (12.84 in)	----
Fitting length	271.5 mm (10.69 in)	----
Spring rate (K1)	29.4 N/mm (3 kgf/mm, 167.87 lb/in)	----
Optional spring	No	----
Stroke (soft) (K1)	0 ~ 90 mm (0.00 ~ 3.54 in)	----
Front wheel:		
Type	Panel wheel	----
Rim size	12 × 6.5AT	----
Rim material	Aluminum	----
Rim runout limit radial	----	2 mm (0.08 in)
lateral	----	2 mm (0.08 in)
Rear wheel:		
Type	Panel wheel	----
Rim size	12 × 75AT	----
Rim material	Aluminum	----
Rim runout limit radial	----	2 mm (0.08 in)
lateral	----	2 mm (0.08 in)

MAINTENANCE SPECIFICATIONS

SPEC



Tightening torques

Part to be tightened	Thread size	Tightening torque			Remarks
		Nm	m·kg	ft·lb	
Final gear case and rear axle housing	M10	63	6.3	45	
Front wheel and wheel hub	M10	55	5.5	40	



ELECTRICAL

Item	Standard	Limit
C.D.I.:		
Magneto model / manufacturer	F4T42571/MITSUBISHI	----
Pickup coil resistance / color	459 ~ 561 Ω at 20°C (68°F) / Red – White	----
Charging coil resistance / color	270 ~ 330 Ω at 20°C (68°F) / Brown – Green	----
Lighting coil resistance / color	0.702 ~ 0.858 Ω / White – White	----
C.D.I. unit model / manufacturer	F8T36071/MITSUBISHI	----
Charging system:		
Type	C.D.I. magneto generator	----
Model / manufacturer	F4T425/MITSUBISHI	----
Nominal output	14 V 12 A at 3,000 r/min	----
Stator coil resistance / color	0.702 ~ 0.858 Ω at 20°C (68°F) / White – White	----
Rectifier:		
Model / manufacturer	SH640-11/SHINDENGEN	----
Capacity	14 A	----
Withstand voltage	200 V	----
Electric starter system:		
Type	Bendix type	----
Starter motor:		
Model / manufacturer	SM-13/MITSUBA	----
I.D. number	SM-13486	----
Output	0.7 kW	----
Armature coil resistance	0.025 ~ 0.035 Ω at 20°C (68°F)	----
Brush overall length	10 mm (0.39 in)	5 mm (0.20 in)
Brush spring pressure	7.65 ~ 10.01 Nm (780 ~ 1.021 gf, 27.5 ~ 36.0 oz)	----
Commutator diameter	28 mm (1.10 in)	27 mm (1.06 in)
Mica undercut	0.7 mm (0.028 in)	----
Starter relay:		
Model / manufacturer	MS5E-691/JIDECO	----
Amperage rating	180 A	----
Coil winding resistance	4.18 ~ 4.62 Ω at 20°C (68°F)	----
Horn:		
Type	Plane type	----
Quantity	1 pcs	----
Model / manufacturer	MF-12/NIKKO	----
Maximum amperage	1.5 A	----
Performance	100 ~ 108 db/2m	----
Coil winding resistance	4.35 ~ 4.80 Ω	----
Thermo unit:		
Model / manufacturer	4SH/DENSO	----



LUBRICATION DIAGRAMS

- ① Oil cooler
- ② Oil cooler hose

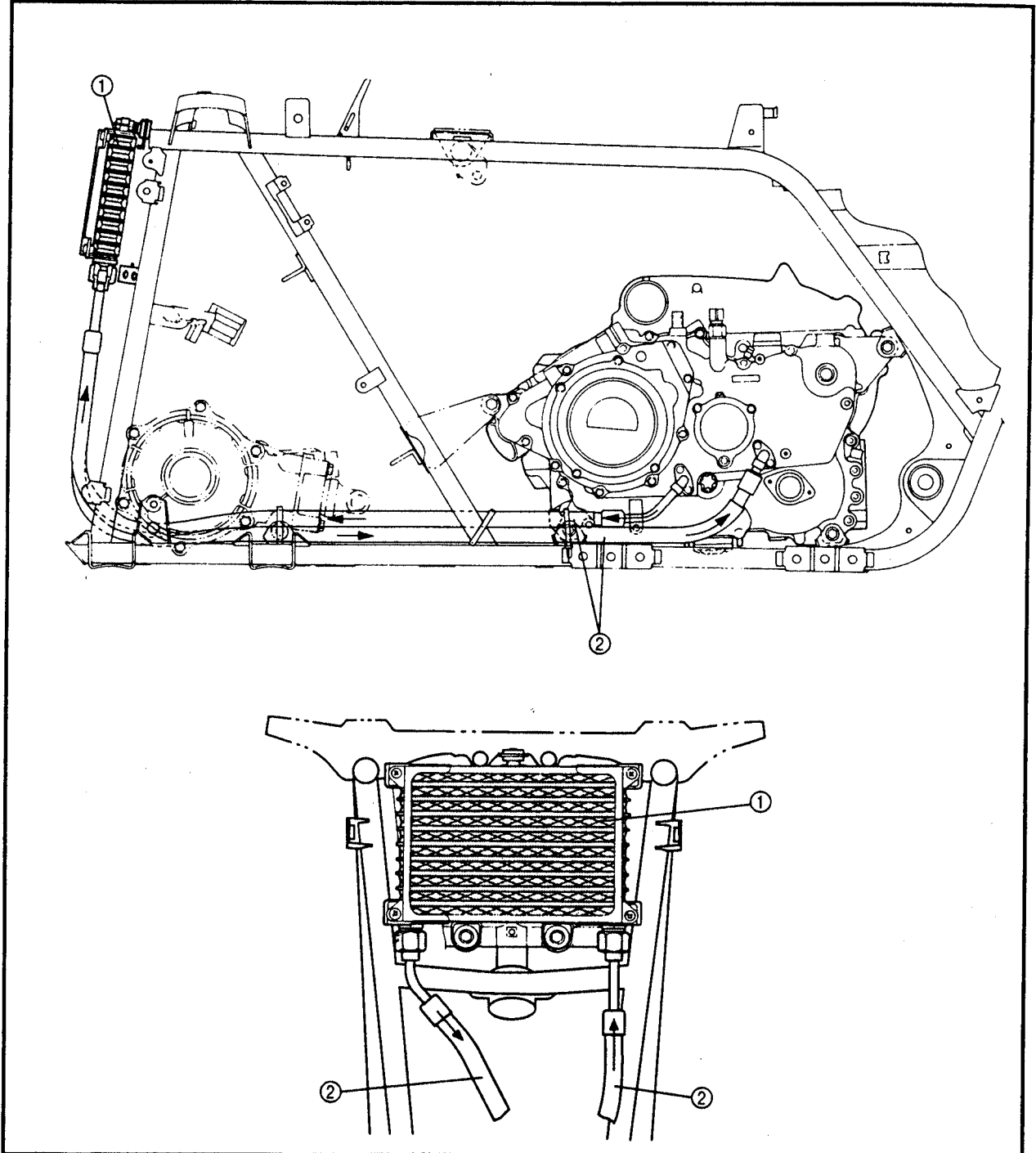

CABLE ROUTING

- ① Rear brake switch
- ② Rear brake cable
- ③ Terminal
- ④ Front brake hose
- ⑤ 2WD/4WD select switch
- ⑥ Fuel tank breather hose
- ⑦ 2WD/4WD select switch lead
- ⑧ Throttle cable
- ⑨ Handlebar switch lead
- ⑩ Rear brake switch lead
- ⑪ Indicator light lead
- ⑫ Main switch lead
- ⑬ Speedometer lead
- ⑭ Brake pipe
- ⑮ Fan motor

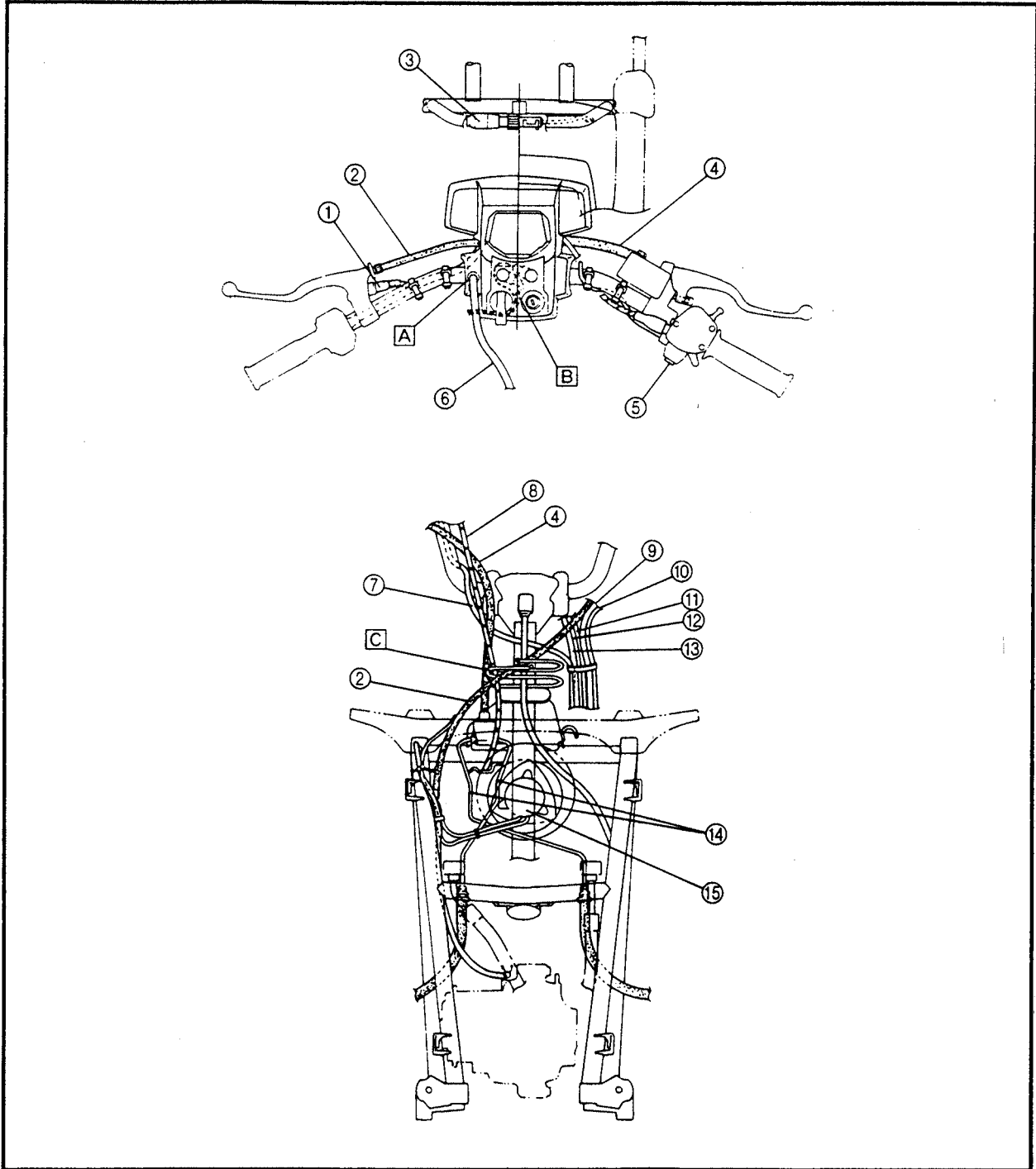



- A Insert the breather hose (fuel tank) into the hole in the handlebar cover.
- B Pass the indicator light leads between the starter knob and main switch, then connect the leads on the inside of the handlebar cover.
- C Pass the rear brake cable through the front part of the cable guide and pass the speedometer cable and throttle cable through the rear part of the cable guide.

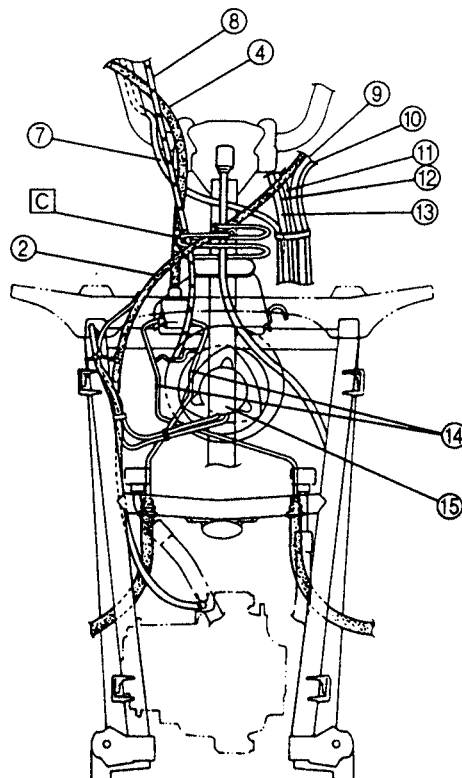
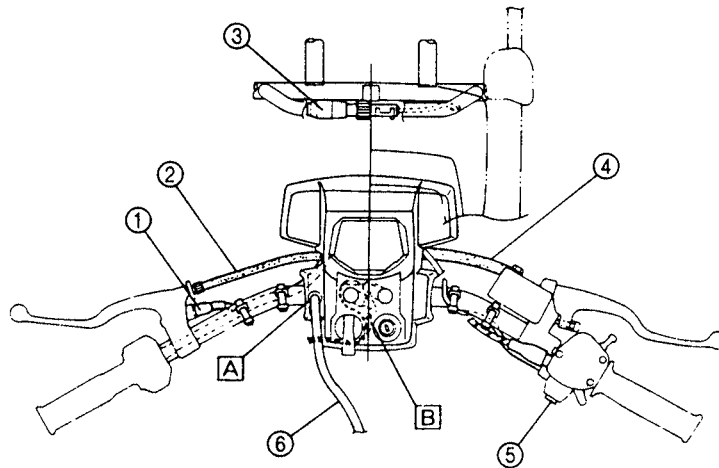

CABLE ROUTING

SPEC



- | | |
|------------------------------|---------------------------------------|
| ① Headlight lead | ⑫ Rear brake breather hose |
| ② Fuel tank breather hose | ⑬ Final drive gear breather hose |
| ③ Rectifier/regulator | ⑭ Battery negative lead (ground lead) |
| ④ CDI unit | ⑮ Starter motor lead |
| ⑤ Carburetor overflow hose | ⑯ Taillight lead |
| ⑥ Carburetor drain hose | ⑰ Wire harness |
| ⑦ Ignition coil | ⑱ Speedometer cable |
| ⑧ Starter relay | ⑲ Oil cooler hose |
| ⑨ Select lever control cable | |
| ⑩ Starter cable | |
| ⑪ Carburetor breather hose | |

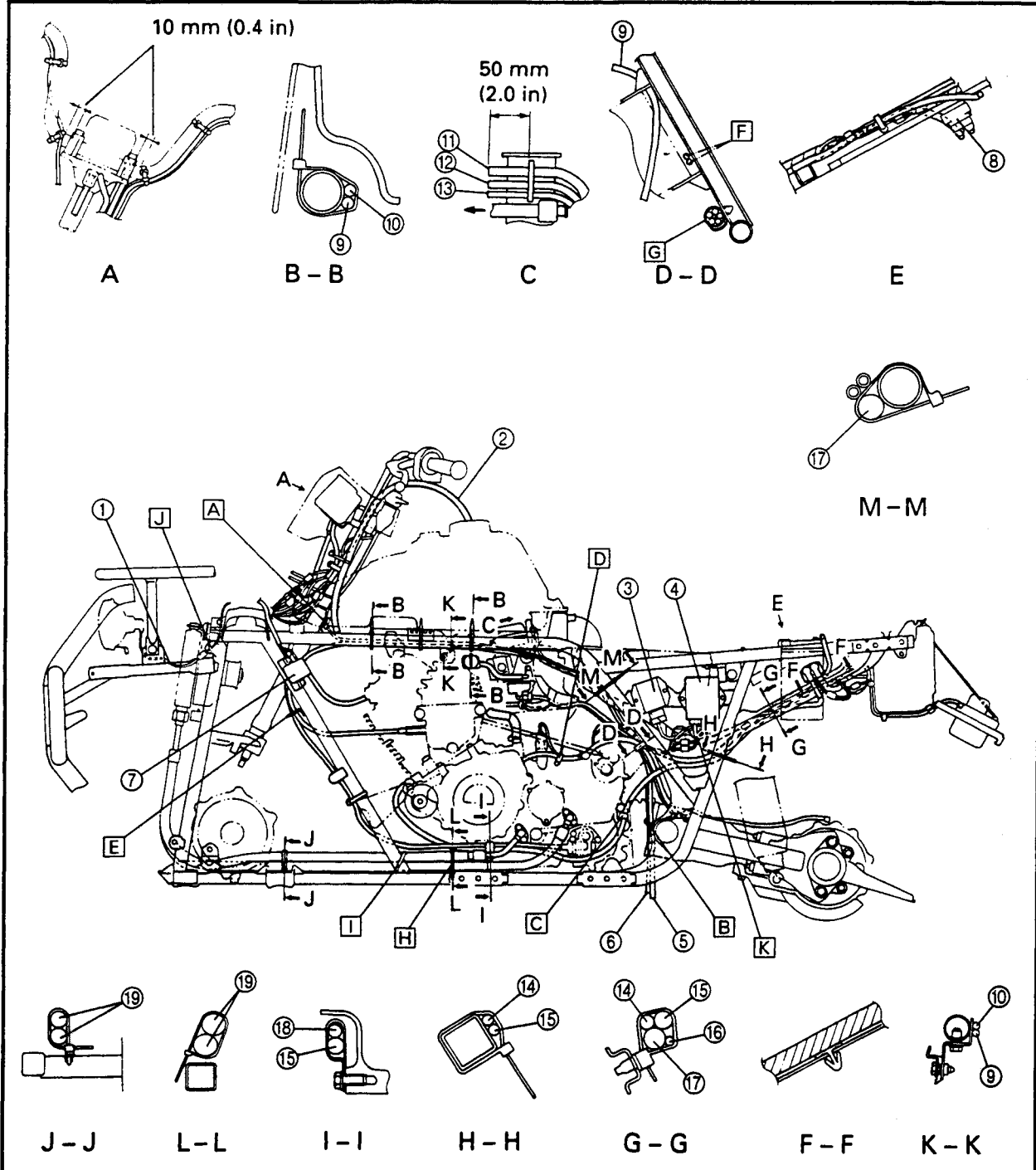

CABLE ROUTING

SPEC



- A** Pass the starter cable through the wire guide.
- B** Pass the carburetor overflow hose and carburetor drain hose through the metal guide on the swingarm.
- C** Fasten the starter motor lead with a metal clamp.
- D** Fasten the CDI magneto lead and thermo unit lead with a metal clamp.
- E** Pass the speedometer cable and select lever control cable through the metal guide.
- F** Pass the carburetor overflow hose and the carburetor drain hose toward the left side of the vehicle and between the engine and the frame.
- G** Fasten the battery negative lead (ground lead), neutral switch/reverse switch lead, starter motor lead, thermo unit lead and rear brake breather hose with a plastic clamp.
- H** Fasten the oil cooler hoses with a plastic locking tie. The plastic locking tie should not be overtightened.
- I** Fasten the oil cooler hoses to the frame with a plastic locking tie. The plastic locking tie should not be overtightened.
- J** Fasten the headlight lead with a plastic clamp.
- K** Pass the rectifier/regulator lead behind the CDI unit lead.

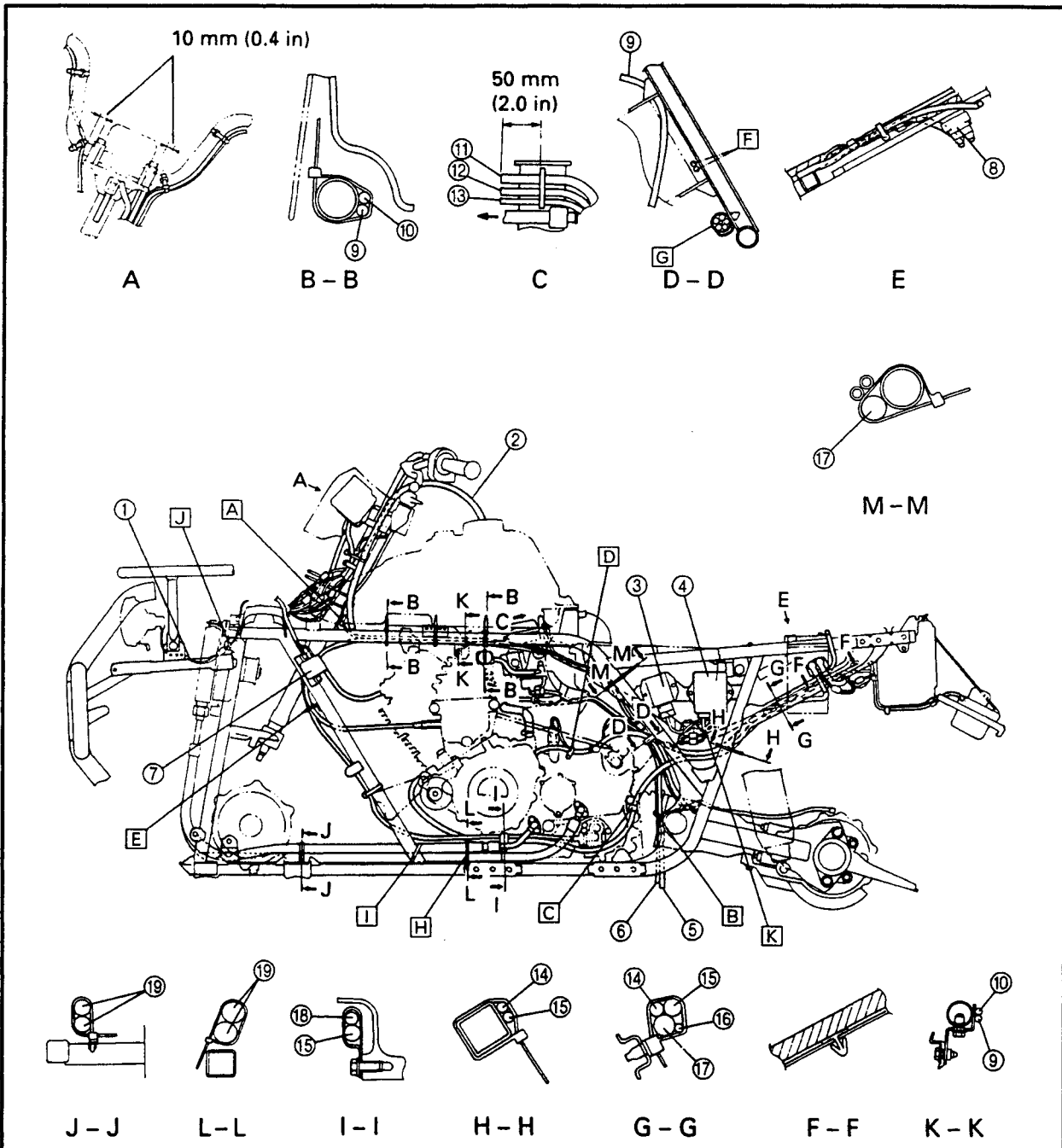

CABLE ROUTING

SPEC



- ① Select lever control cable
- ② Gear motor
- ③ 4WD switch
- ④ Rear brake cable (brake lever)
- ⑤ Rear brake cable (brake pedal)
- ⑥ Fan motor breather hose
- ⑦ Differential gear breather hose
- ⑧ Gear motor lead

- A Pass the throttle cable through the metal guide.
- B Pass the differential gear breather hose and fan motor breather hose through the hole in the right side frame.
- C Fasten the fan motor breather hose and differential gear breather hose with a plastic clip.
- D Pass the rear brake cable (brake lever) through the metal guide.

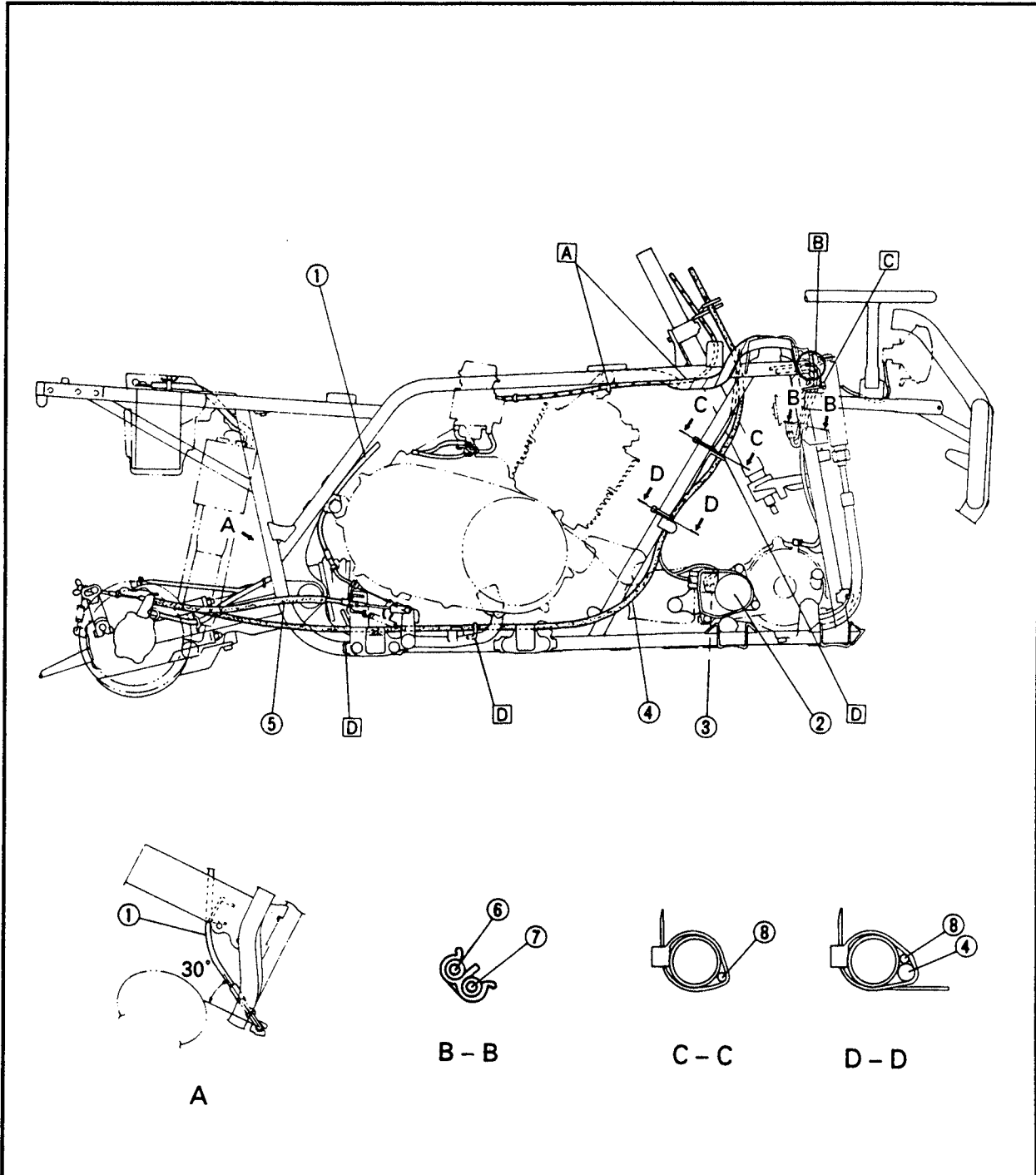



- ① Headlight lead
- ② Diode
- ③ Wire harness
- ④ Throttle cable
- ⑤ Select lever control cable
- ⑥ Main fuse
- ⑦ Terminal fuse
- ⑧ Battery
- ⑨ Starter cable
- ⑩ Taillight lead
- ⑪ Rear brake breather hose
- ⑫ Final drive gear breather hose
- ⑬ Fuse lead
- ⑭ Fan motor control unit
- ⑮ Reverse relay
- ⑯ Fan motor relay
- ⑰ Starting circuit cut-off relay

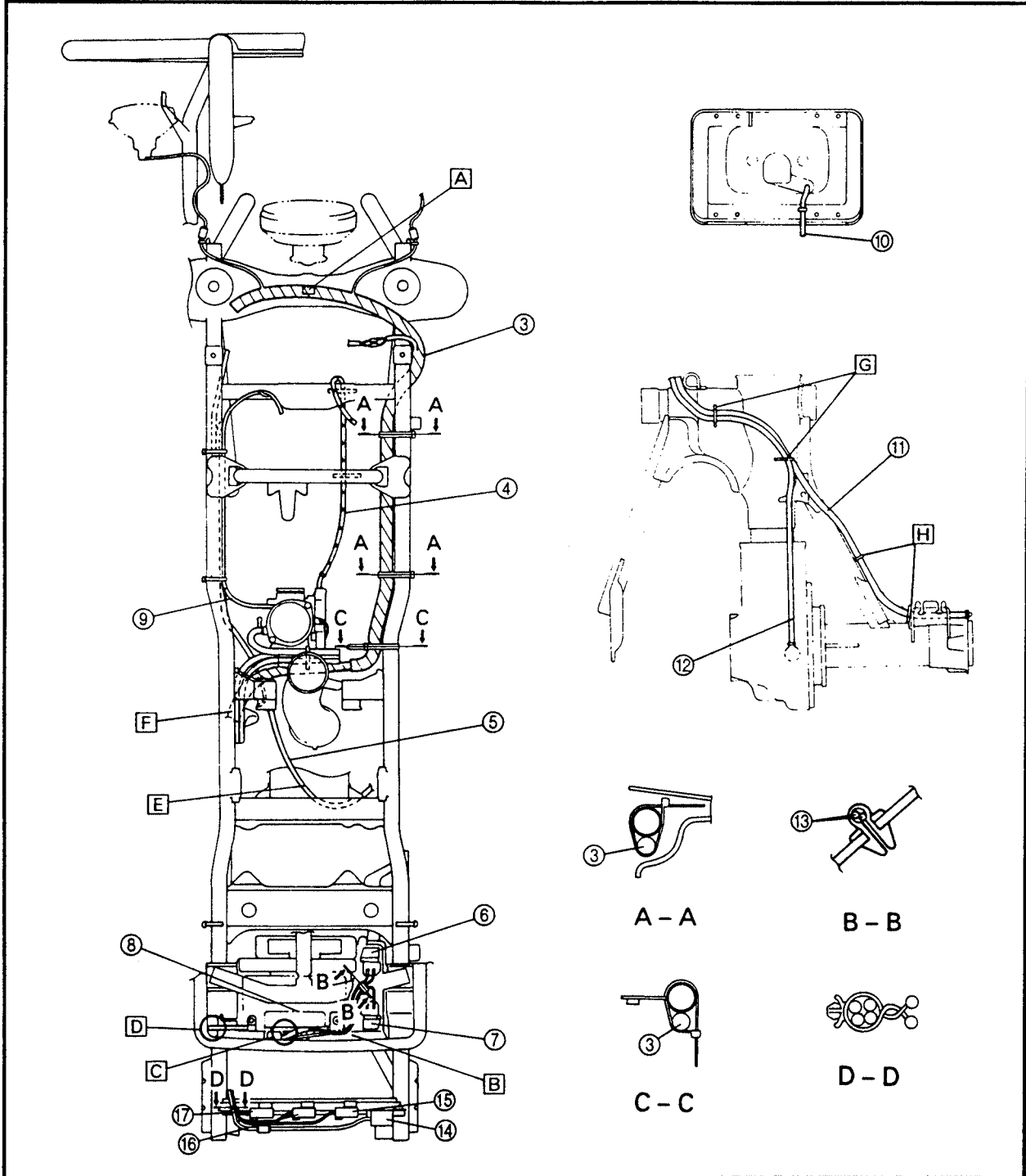



- A Insert the wire harness T-joint into the hole in the frame.
- B Pass the fuse lead under the battery positive lead.
- C Pass the battery positive lead and the fuse lead through the hole in the rear fender.
- D Pass the battery negative lead through the hole in the rear fender.
- E Pass the select lever control cable between the engine and the frame.

- F Pass the final drive gear breather hose and the rear brake breather hose over the air filter case mounting bracket on the frame.
- G Pass the rear brake breather hose and the final drive gear breather hose through the metal guides on the swingarm.
- H Pass the rear brake breather hose through the metal guides on the swingarm.

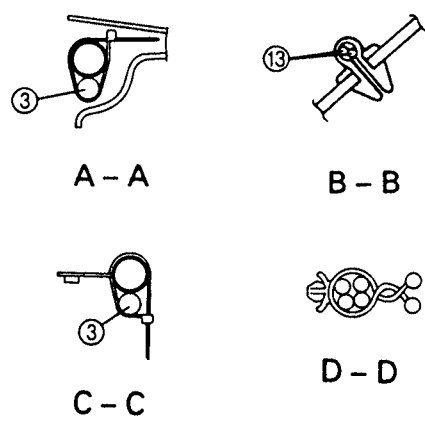
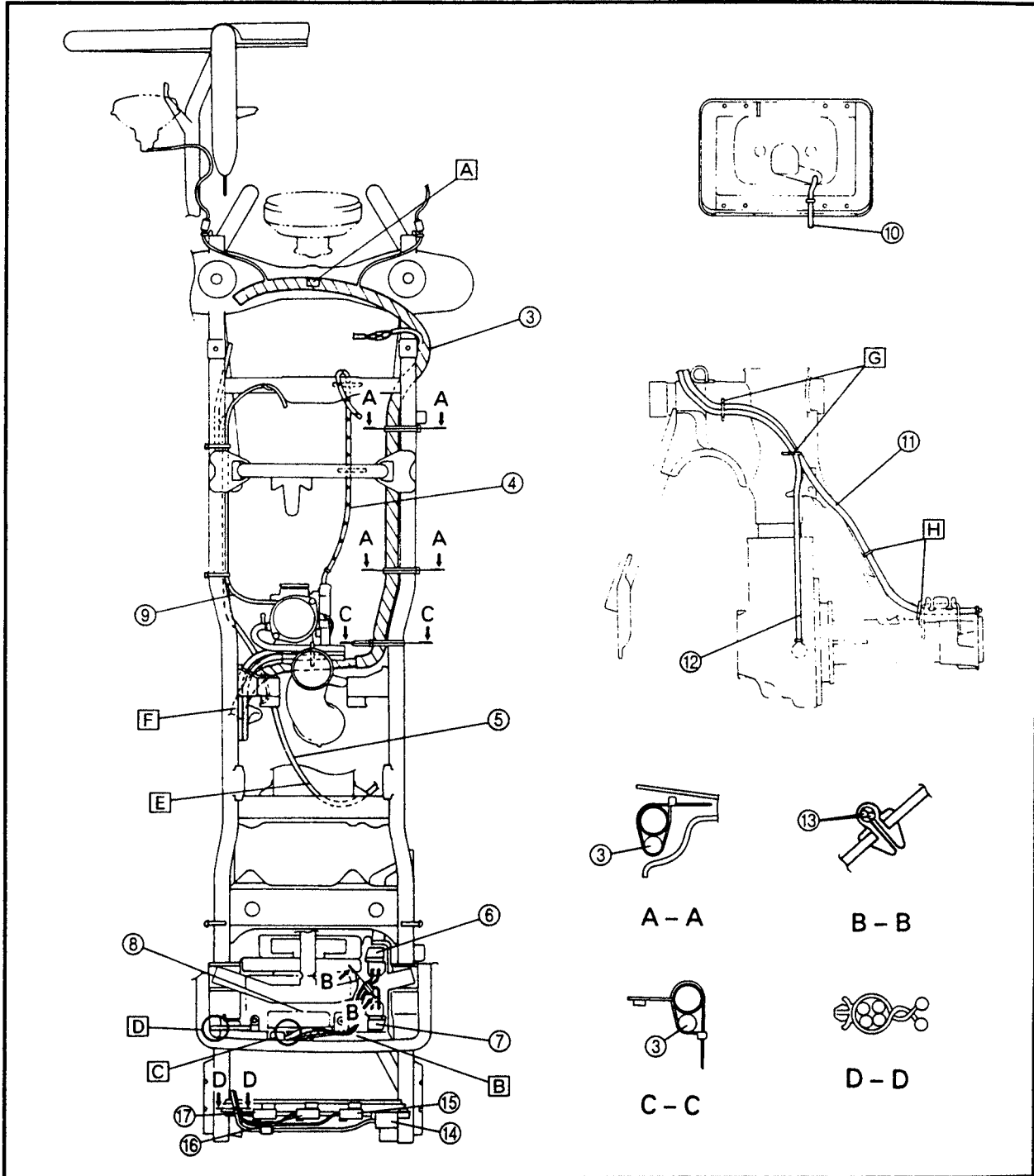

YAMAHA

YFM600FWACK
(for California)

SUPPLEMENTARY
SERVICE MANUAL

FOREWORD

This Supplementary Service Manual has been prepared to introduce new service and data for the YFM600FWACK. For complete service information procedures it is necessary to use this Supplementary Service Manual together with the following manual.

YFM600FWAK SERVICE MANUAL: LIT-11616-11-02 (4WV-F8197-E0)

**YFM600FWACK
SUPPLEMENTARY
SERVICE MANUAL**

©1997 by Yamaha Motor Corporation, U.S.A.

First Edition, July 1997

**All rights reserved. Any reproduction or
unauthorized use without the written
permission of Yamaha Motor Corporation, U.S.A.
is expressly prohibited.**

Printer in U.S.A.

LIT-11616-11-21

NOTICE

This manual was produced by the Yamaha Motor Company primarily for use by Yamaha dealers and their qualified mechanics. It is not possible to include all the knowledge of a mechanic in one manual, so it is assumed that anyone who uses this book to perform maintenance and repairs on Yamaha machine has a basic understanding of the mechanical ideas and the procedures of machine repair. Repairs attempted by anyone without this knowledge are likely to render the machine unsafe and unfit for use.

Yamaha Motor Company, Ltd. is continually striving to improve all its models. Modifications and significant changes in specifications or procedures will be forwarded to all authorized Yamaha dealers and will appear in future editions of this manual where applicable.

NOTE:

Designs and specifications are subject to change without notice.

IMPORTANT INFORMATION

Particularly important information is distinguished in this manual by the following notations.



The Safety Alert Symbol means ATTENTION! BECOME ALERT! YOUR SAFETY IS INVOLVED!

⚠ WARNING

Failure to follow **WARNING** instructions could result in severe injury or death to the machine operator, a bystander or a person inspecting or repairing the machine.

CAUTION:

A CAUTION indicates special precautions that must be taken to avoid damage to the machine.

NOTE:

A NOTE provides key information to make procedures easier or clearer.

HOW TO USE THIS MANUAL

MANUAL ORGANIZATION

This manual consists of chapters for the main categories of subjects. (See "Illustrated symbols")

1st title ①: This is the title of the chapter with its symbol in the upper right corner of each page.

2nd title ②: This title indicates the section of the chapter and only appears on the first page of each section. It is located in the upper left corner of the page.

3rd title ③: This title indicates a sub-section that is followed by step-by-step procedures accompanied by corresponding illustrations.

EXPLODED DIAGRAMS

To help identify parts and clarify procedure steps, there are exploded diagrams at the start of each removal and disassembly section.

1. An easy-to-see exploded diagram ④ is provided for removal and disassembly jobs.
2. Numbers ⑤ are given in the order of the jobs in the exploded diagram. A number that is enclosed by a circle indicates a disassembly step.
3. An explanation of jobs and notes is presented in an easy-to-read way by the use of symbol marks ⑥. The meanings of the symbol marks are given on the next page.
4. A job instruction chart ⑦ accompanies the exploded diagram, providing the order of jobs, names of parts, notes in jobs, etc.
5. For jobs requiring more information, the step-by-step format supplements ⑧ are given in addition to the exploded diagram and the job instruction chart.

The diagram illustrates the clutch assembly and its removal procedure. It includes an exploded view of the clutch components, a job instruction chart, and a step-by-step removal procedure with illustrations and notes.

CLUTCH REMOVAL

1. Remove
 - Clutch housing assembly
 - Gasket
 - Dowel pins

NOTE:
Working in clockwise pattern, loosen each bolt 1/4 of turn. Remove them after all of them are loosened.

2. Straighten
 - Punched portion of the nut ①
3. Remove
 - Nut ②

NOTE:
Use a clutch holding tool ③ to hold the clutch carrier assembly.

Clutch holding tool P/N: 796-916A2, 90890-04066

CLUTCH INSPECTION

1. Inspect
 - Clutch housing ④
 - Heat damage/wear/damage → Replace
 - One-way clutch bearing ⑤
 - Chalmers/wear/damage → Replace

NOTE:
• Replace the one-way clutch assembly and clutch housing as a set.
• The one way clutch bearing must be installed with the flange side facing in.

Clutch operation:
• Install the one way clutch bearing and clutch carrier assembly to the clutch housing and hold the clutch carrier assembly.
• When turning the clutch housing clockwise ⑥, the clutch housing should turn freely.
• If not, the one-way clutch assembly is faulty.
• Replace it.
• When turning the clutch housing counter-clockwise ⑦, the clutch housing and crankshaft should be engaged.
• If not, the one way clutch assembly is faulty.
• Replace it.

Job Instruction Chart:

Order	Job name/Part name	Qty	Remarks
	Clutch removed		Remove the parts in the order below. Refer to "PRIMARY AND SECONDARY SHAFTS"
1	Cover	1	
2	Clutch housing assembly	1	
3	Gasket / Dowel pin	1	
4	One-way clutch bearing	1/2	Refer to "CLUTCH REMOVAL / INSTALLATION"
5	Nut	1	
6	Clutch carrier assembly	1	
7	Collar	1	For installation, reverse the removal procedure

ILLUSTRATED SYMBOLS

Illustrated symbols ① to ⑨ are printed on the top right of each page and indicate the subject of each chapter.

- ① General information
- ② Specifications
- ③ Periodic inspections and adjustments
- ④ Engine
- ⑤ Carburetion
- ⑥ Drive train
- ⑦ Chassis
- ⑧ Electrical
- ⑨ Troubleshooting

Illustrated symbols ⑩ to ⑰ are used to identify the specifications appearing in the text.

- ⑩ Can be serviced with engine mounted
- ⑪ Filling fluid
- ⑫ Lubricant
- ⑬ Special tool
- ⑭ Torque
- ⑮ Wear limit, clearance
- ⑯ Engine speed
- ⑰ Ω , V, A

Illustrated symbols ⑱ to ⑳ in the exploded diagrams indicate the types of lubricants and lubrication points.

- ⑱ Apply engine oil
- ⑲ Apply gear oil
- ㉑ Apply molybdenum disulfide oil
- ㉒ Apply wheel bearing grease
- ㉓ Apply lightweight lithium-soap base grease
- ㉔ Apply molybdenum disulfide grease

Illustrated symbols ㉕ to ㉖ in the exploded diagrams indicate where to apply a locking agent ㉕ and when to install a new part ㉖.

- ㉕ Apply the locking agent (LOCTITE®)
- ㉖ Replace

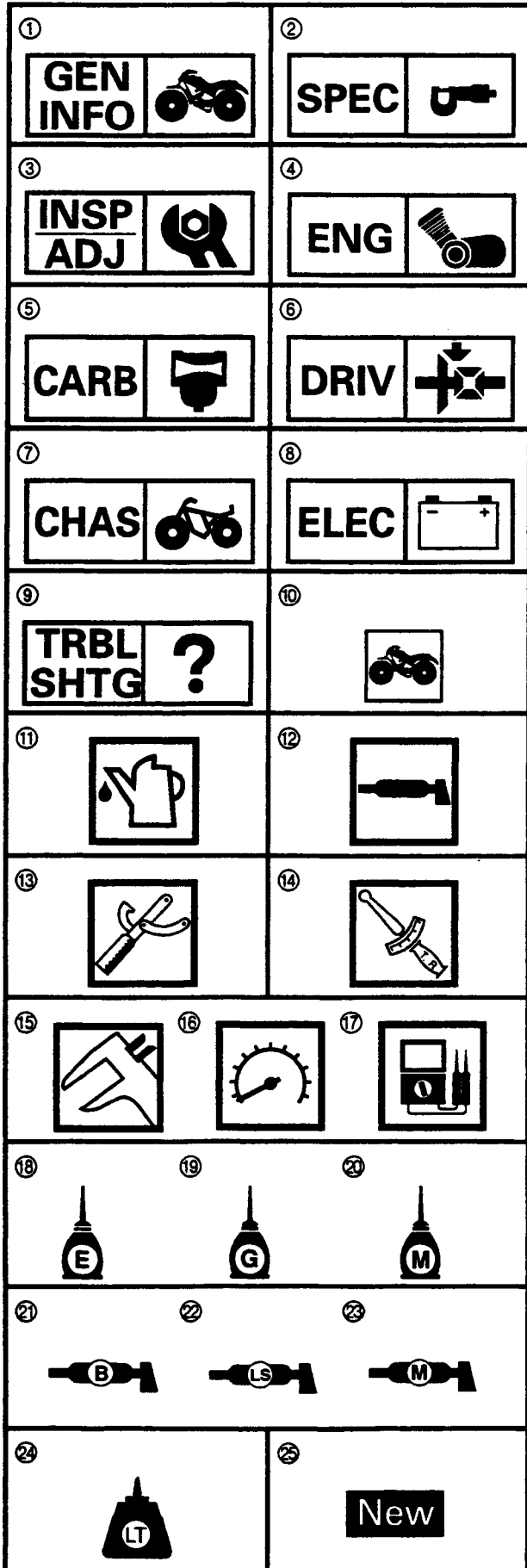

CONTENTS

SPECIFICATIONS	1
GENERAL SPECIFICATIONS	1
MAINTENANCE SPECIFICATIONS	1
ENGINE	1



SPECIFICATIONS

GENERAL SPECIFICATIONS

Item	Standard
Model code:	4WV3

**MAINTENANCE SPECIFICATIONS
ENGINE**

Item	Standard	Limit
Carburetor:		
I. D. mark	4WV 10	----
Main jet (M.J)	#143.8	----
Main air jet (M.A.J)	0.6	----
Jet needle (J.N)	6HH24-94-1	----
Needle jet (N.J)	Y-0M (#782)	----
Pilot air jet (P.A.J.1)	0.7	----
Pilot air jet (P.A.J.2)	1.0	----
Pilot outlet (P.O)	1.1	----
Pilot jet (P.J)	#42.5	----
Bypass 1 (B.P.1)	1.0	----
Bypass 2 (B.P.2)	0.8	----
Bypass 3 (B.P.3)	0.8	----
Pilot screw (P.S)	3 1/2	----
Valve seat size (V.S)	2.8	----
Starter jet (G.S.1)	#100	----
Throttle valve size (Th.V)	#110	----
Float height (F.H)	14.7 mm (0.59 in)	----
Fuel level (F.L)	2 ~ 3 mm (0.08 ~ 0.12 in)	----
Engine idle speed	1,350 ~ 1,450 r/min	----
Intake vacuum	30.8 kPa (231 mmHg, 9.09 inHg)	----

YAMAHA
YAMAHA MOTOR CO., LTD.
2500 SHINGAI IWATA SHIZUOKA JAPAN

PRINTED IN U.S.A.

YAMAHA

YFM600FWAK

SERVICE MANUAL

**YFM600FWAK
SERVICE MANUAL**

**© 1997 by Yamaha Motor Corporation, U.S.A.
First Edition, April 1997**

**All rights reserved. Any reproduction or
unauthorized use without the written
permission of Yamaha Motor Corporation, U.S.A.
is expressly prohibited.**

**Printed in U.S.A.
LIT-11616-11-02**

NOTICE

This manual was produced by the Yamaha Motor Company primarily for use by Yamaha dealers and their qualified mechanics. It is not possible to include all the knowledge of a mechanic in one manual, so it is assumed that anyone who uses this book to perform maintenance and repairs on Yamaha machine has a basic understanding of the mechanical ideas and the procedures of machine repair. Repairs attempted by anyone without this knowledge are likely to render the machine unsafe and unfit for use.

Yamaha Motor Company, Ltd. is continually striving to improve all its models. Modifications and significant changes in specifications or procedures will be forwarded to all authorized Yamaha dealers and will appear in future editions of this manual where applicable.

NOTE: _____
Designs and specifications are subject to change without notice.

IMPORTANT INFORMATION

Particularly important information is distinguished in this manual by the following notations.



The Safety Alert Symbol means ATTENTION! BECOME ALERT! YOUR SAFETY IS INVOLVED!

WARNING

Failure to follow WARNING instructions could result in severe injury or death to the machine operator, a bystander or a person inspecting or repairing the machine.

CAUTION

A CAUTION indicates special precautions that must be taken to avoid damage to the machine.

NOTE: A NOTE provides key information to make procedures easier or clearer.

HOW TO USE THIS MANUAL

MANUAL ORGANIZATION

This manual consists of chapters for the main categories of subjects. (See "Illustrated symbols")

1st title ①: This is the title of the chapter with its symbol in the upper right corner of each page.

2nd title ②: This title indicates the section of the chapter and only appears on the first page of each section. It is located in the upper left corner of the page.

3rd title ③: This title indicates a sub-section that is followed by step-by-step procedures accompanied by corresponding illustrations.

EXPLODED DIAGRAMS

To help identify parts and clarify procedure steps, there are exploded diagrams at the start of each removal and disassembly section.

1. An easy-to-see exploded diagram ④ is provided for removal and disassembly jobs.
2. Numbers ⑤ are given in the order of the jobs in the exploded diagram. A number that is enclosed by a circle indicates a disassembly step.
3. An explanation of jobs and notes is presented in an easy-to-read way by the use of symbol marks ⑥. The meanings of the symbol marks are given on the next page.
4. A job instruction chart ⑦ accompanies the exploded diagram, providing the order of jobs, names of parts, notes in jobs, etc.
5. For jobs requiring more information, the step-by-step format supplements ⑧ are given in addition to the exploded diagram and the job instruction chart.

②
①

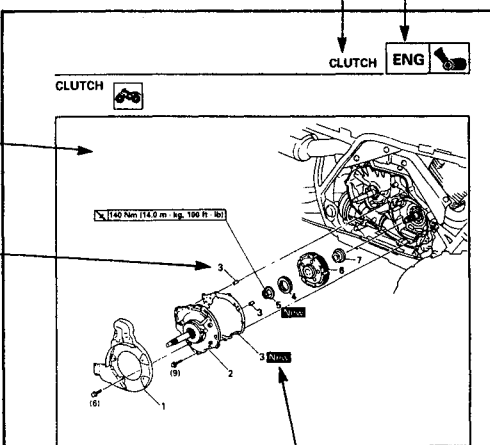

CLUTCH ENG

④

⑤

⑦

Order	Job name/Part name	Qty	Remarks
	Clutch removal		Remove the parts in the order below.
	Primary and secondary sheaves		Refer to "PRIMARY AND SECONDARY SHEAVES".
1	Cover	1	
2	Clutch housing assembly	1	
3	Gasket / dowel pin	1/2	Refer to "CLUTCH REMOVAL / INSTALLATION".
4	One-way clutch bearing	1	
5	Nut	1	
6	Clutch carrier assembly	1	
7	Collar	1	For installation, reverse the removal procedure.

⑥

CLUTCH
ENG

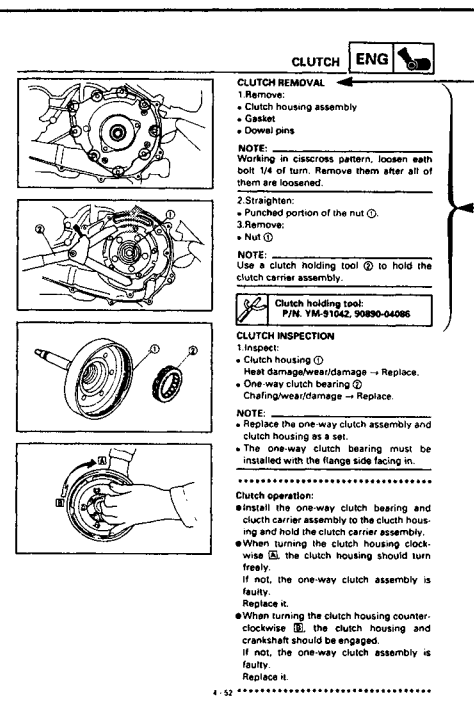

CLUTCH ENG

















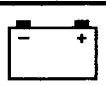







③

⑧

ILLUSTRATED SYMBOLS

Illustrated symbols ① to ⑨ are printed on the top right of each page and indicate the subject of each chapter.

- ① General information
- ② Specifications
- ③ Periodic inspections and adjustments
- ④ Engine
- ⑤ Carburetion
- ⑥ Drive train
- ⑦ Chassis
- ⑧ Electrical
- ⑨ Troubleshooting

① GEN INFO 	② SPEC 	
③ INSP ADJ 	④ ENG 	
⑤ CARB 	⑥ DRIV 	
⑦ CHAS 	⑧ ELEC 	
⑨ TRBL SHTG ? 	⑩ 	
⑪ 	⑫ 	
⑬ 	⑭ 	
⑮ 	⑯ 	⑰ 
⑱ 	⑲ 	⑳ 
㉑ 	㉒ 	㉓ 
㉔ 	㉕ 	

Illustrated symbols ⑩ to ⑰ are used to identify the specifications appearing in the text.

- ⑩ Can be serviced with engine mounted
- ⑪ Filling fluid
- ⑫ Lubricant
- ⑬ Special tool
- ⑭ Torque
- ⑮ Wear limit, clearance
- ⑯ Engine speed
- ⑰ Ω, V, A









Illustrated symbols ⑱ to ㉓ in the exploded diagrams indicate the types of lubricants and lubrication points.

- ⑱ Apply engine oil
- ⑲ Apply gear oil
- ⑳ Apply molybdenum disulfide oil
- ㉑ Apply wheel bearing grease
- ㉒ Apply lightweight lithium-soap base grease
- ㉓ Apply molybdenum disulfide grease

Illustrated symbols ㉔ to ㉕ in the exploded diagrams indicate where to apply a locking agent ㉔ and when to install a new part ㉕.

- ㉔ Apply the locking agent (LOCTITE®)
- ㉕ Replace

CHAPTER TITLES

GENERAL INFORMATION	 GEN INFO 1
SPECIFICATIONS	 SPEC 2
PERIODIC INSPECTION AND ADJUSTMENT	 INSP ADJ 3
ENGINE OVERHAUL	 ENG 4
CARBURETION	 CARB 5
DRIVE TRAIN	 DRIVE 6
CHASSIS	 CHAS 7
ELECTRICAL	 ELEC 8
TROUBLESHOOTING	 TRBL SHTG 9









CONTENTS

CHAPTER 1. GENERAL INFORMATION

MACHINE IDENTIFICATION	1-1
VEHICLE IDENTIFICATION NUMBER	1-1
MODEL LABEL	1-1
 FEATURES	 1-2
 IMPORTANT INFORMATION	 1-7
PREPARATION FOR REMOVAL PROCEDURES	1-7
REPLACEMENT PARTS	1-7
GASKETS, OIL SEALS AND O-RINGS	1-7
LOCK WASHERS/PLATES AND COTTER PINS	1-8
BEARINGS AND OIL SEALS	1-8
CIRCLIPS	1-8
 CHECKING OF CONNECTIONS	 1-9
 SPECIAL TOOLS	 1-10

CHAPTER 2. SPECIFICATIONS

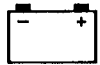
GENERAL SPECIFICATIONS	2-1
 MAINTENANCE SPECIFICATIONS	 2-4
ENGINE	2-4
CHASSIS	2-14
ELECTRICAL	2-18
 HOW TO USE THE CONVERSION TABLE	 2-20
 GENERAL TORQUE SPECIFICATIONS	 2-20
 LUBRICATION POINTS AND LUBRICANT TYPES	 2-21
ENGINE	2-21
 LUBRICATION DIAGRAMS	 2-22
 CABLE ROUTING	 2-25

	GEN INFO	1
	SPEC	2
	INSP ADJ	3
	ENG	4
	CARB	5
	DRIVE	6
	CHAS	7
	ELEC	8
	TRBL SHTG	9

CHAPTER 3. PERIODIC INSPECTIONS AND ADJUSTMENTS

INTRODUCTION	3-1
PERIODIC MAINTENANCE/LUBRICATION INTERVALS	3-1
SEAT, CARRIERS, FENDERS AND FUEL TANK	3-3
SEAT	3-3
FRONT CARRIER, FRONT BUMPER AND FRONT FENDER	3-4
REAR CARRIER AND REAR FENDER	3-5
FUEL TANK	3-6
ENGINE	3-7
VALVE CLEARANCE ADJUSTMENT	3-7
TIMING CHAIN ADJUSTMENT	3-10
IDLING SPEED ADJUSTMENT	3-10
THROTTLE LEVER FREE PLAY ADJUSTMENT	3-11
SPEED LIMITER ADJUSTMENT	3-13
SPARK PLUG INSPECTION	3-14
IGNITION TIMING CHECK	3-15
COMPRESSION PRESSURE MEASUREMENT	3-16
ENGINE OIL LEVEL INSPECTION	3-17
OIL TEMP WARNING LIGHT CHECK	3-18
ENGINE OIL REPLACEMENT	3-19
AIR FILTER CLEANING	3-20
V-BELT INSPECTION	3-22
CHASSIS	3-24
FRONT BRAKE ADJUSTMENT	3-24
REAR BRAKE LEVER AND PEDAL ADJUSTMENT	3-24
FRONT BRAKE FLUID LEVEL INSPECTION	3-26
FRONT BRAKE PAD INSPECTION	3-27
REAR BRAKE SHOE INSPECTION	3-27
BRAKE HOSE INSPECTION	3-28
AIR BLEEDING (HYDRAULIC BRAKE SYSTEM)	3-28
SELECT LEVER CONTROL CABLE AND SHIFT ROD ADJUSTMENT	3-30
FINAL GEAR OIL LEVEL INSPECTION	3-31
FINAL GEAR REPLACEMENT	3-31
DIFFERENTIAL GEAR OIL REPLACEMENT	3-32
CONSTANT VELOCITY JOINT DUST BOOT INSPECTION	3-33
STEERING SYSTEM INSPECTION	3-33
TOE-IN ADJUSTMENT	3-34
REAR SHOCK ABSORBER ADJUSTMENT	3-36
TIRE INSPECTION	3-36
WHEEL INSPECTION	3-38
CABLE INSPECTION AND LUBRICATION	3-39
LEVERS, PEDAL, ETC. LUBRICATION	3-39

ELECTRICAL	3-40
BATTERY INSPECTION	3-40
FUSE INSPECTION	3-45
HEADLIGHT BEAM ADJUSTMENT	3-47
HEADLIGHT BULB REPLACEMENT	3-47

CHAPTER 4. ENGINE

ENGINE REMOVAL	4-1
AIR DUCTS, MUFFLER, EXHAUST PIPE, AND FOOTLEST BOARD (right).....	4-1
SELECT LEVER UNIT AND FOOTREST BOARD (left).....	4-2
HOSES AND LEADS	4-3
ENGINE MOUNTING BOLTS	4-4
 CYLINDER HEAD COVER	4-6
CYLINDER HEAD COVER REMOVAL	4-7
CYLINDER HEAD COVER INSPECTION	4-7
TAPPET COVER INSPECTION	4-7
CYLINDER HEAD COVER INSTALLATION	4-8
 ROCKER ARMS	4-9
ROCKER ARM REMOVAL	4-10
ROCKER ARM AND CAMSHAFT INSPECTION	4-10
ROCKER ARM INSTALLATION	4-11
 CAMSHAFT AND CYLINDER HEAD	4-12
CAMSHAFT AND CYLINDER HEAD REMOVAL	4-14
CAMSHAFT INSPECTION	4-15
CAMSHAFT SPROCKET INSPECTION	4-15
DECOMPRESSION SYSTEM INSPECTION	4-15
TIMING CHAIN GUIDE INSPECTION	4-16
TIMING CHAIN TENTIONER INSPECTION	4-16
CYLINDER HEAD INSPECTION	4-16
CAMSHAFT AND CYLINDER HEAD INSTALLATION	4-17
 VALVES AND VALVE SPRINGS	4-20
VALVE AND VALVE SPRING REMOVAL	4-21
VALVE AND VALVE SPRING INSPECTION	4-21
VALVE AND VALVE SPRING INSTALLATION	4-26
 CYLINDER AND PISTON	4-27
PISTON REMOVAL	4-28
CYLINDER AND PISTON INSPECTION	4-28
PISTON RING INSPECTION	4-30
PISTON PIN INSPECTION	4-31



**GEN
INFO** **1**



SPEC **2**



**INSP
ADJ** **3**



ENG **4**



CARB **5**



DRIVE **6**



CHAS **7**

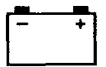

ELEC **8**



**TRBL
SHTG** **9**

PISTON INSTALLATION	4-31
CYLINDER INSTALLATION	4-32
RECOIL STARTER AND CDI MAGNETO	4-33
CDI MAGNETO REMOVAL	4-36
RECOIL STARTER DISASSEMBLY	4-36
CDI MAGNETO INSPECTION	4-37
STARTER PULLEY INSPECTION	4-37
RECOIL STARTER INSPECTION	4-37
RECOIL STARTER ASSEMBLY	4-38
CDI MAGNETO INSTALLATION	4-39
PRIMARY AND SECONDARY SHEAVES	4-41
PRIMARY SEAVE	4-43
SECONDARY SHEAVE	4-44
PRIMARY AND SECONARY SHEAVES REMOVAL	4-45
SECONDARY SHEAVE DISASSEMBLY	4-45
PRIMARY SHEAVE INSPECTION	4-46
SECONDARY SHEAVE INSPECTION	4-46
PRIMARY SHEAVE ASSEMBLY	4-47
SECONDARY SHEAVE ASSEMBLY	4-47
PRIMARY AND SECONDARY SHEAVE INSTALLATION	4-49
CLUTCH	4-50
CLUTCH REMOVAL	4-52
CLUTCH INSPECTION	4-52
CLUTCH INSTALLATION	4-53
CRANKCASE	4-55
STARTER MOTOR, TIMING CHAIN AND OIL FILTER	4-55
CRANKCASE	4-57
CRANKCASE BEARINGS	4-58
CRANKCASE SEPARATION	4-59
TIMING CHAIN AND GUIDE INSPECTION	4-59
OIL STRAINER, OIL FILTER AND OIL DELIVERY PIPE INSPECTION	4-60
CRANKCASE INSPECTION	4-60
BEARINGS AND OIL SEALS INSPECTION	4-60
CRANKCASE ASSEMBLY	4-61
TRANSMISSION AND CRANKSHAFT	4-62
CRANKSHAFT REMOVAL	4-63
SHIFT FORK INSPECTION	4-63
SHIFT CAM INSPECTION	4-64
TRANSMISSION INSPECTION	4-64
CRANKSHAFT INSPECTION	4-65
CRANKSHAFT AND BALANCER INSTALLATION	4-66
TRANSMISSION INSTALLATION	4-66

OIL PUMP	4-68
OIL PUMP INSPECTION	4-71
MIDDLE GEAR	4-72
MIDDLE DRIVE SHAFT	4-72
MIDDLE DRIVEN SHAFT	4-73
MIDDLE DRIVE SHAFT REMOVAL	4-75
MIDDLE DRIVEN SHAFT REMOVAL	4-75
INSPECTION	4-77
MIDDLE DRIVE AND DRIVEN GEAR SHIM SELECTION	4-78
MIDDLE DRIVEN SHAFT INSTALLATION	4-81
MIDDLE DRIVE SHAFT INSTALLATION	4-83
GEAR LASH MEASUREMENT	4-84

CHAPTER 5. CARBURETION

CARBURETOR	5-1
CARBURETOR DISASSEMBLY	5-4
CARBURETOR INSPECTION	5-4
CARBURETOR ASSEMBLY	5-6
FUEL LEVEL ADJUSTMENT	5-7

CHAPTER 6. DRIVE TRAIN

TROUBLESHOOTING	6-1
CONSTANT VELOCITY JOINTS AND DIFFERENTIAL GEAR	6-4
UNIVERSAL JOINT DISASSEMBLY	6-9
DIFFERENTIAL GEAR DISASSEMBLY	6-9
CONSTANT VELOCITY JOINT INSPECTION	6-10
DIFFERENTIAL GEAR INSPECTION	6-10
CONSTANT VELOCITY JOINT ASSEMBLY	6-11
DIFFERENTIAL GEAR ASSEMBLY	6-12
UNIVERSAL JOINT INSTALLATION	6-12
DIFFERENTIAL GEAR LASH MEASUREMENT AND ADJUSTMENT	6-13
DIFFERENTIAL GEAR OPERATION CHECK	6-15
REAR AXLE/FINAL DRIVE GEAR AND DRIVE SHAFT	6-16
REAR AXLE REMOVAL	6-19
FINAL DRIVE GEAR DISASSEMBLY	6-19
FINAL DRIVE ROLLER BEARING REMOVAL AND REASSEMBLY	6-20
FINAL DRIVE PINION GEAR AND RING GEAR POSITIONING	6-21



**GEN
INFO 1**



SPEC 2



**INSP
ADJ 3**



ENG 4



CARB 5



DRIVE 6



CHAS 7

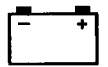

ELEC 8



**TRBL
SHTG 9**

REAR AXLE INSPECTION	6-25
DRIVE SHAFT INSPECTION	6-26
FINAL DRIVE GEAR INSPECTION	6-26
FINAL GEAR LASH MEASUREMENT AND ADJUSTMENT	6-27
FINAL DRIVE GEAR ASSEMBLY	6-29
REAR AXLE INSTALLATION	6-29

CHAPTER 7. CHASSIS

FRONT AND REAR WHEELS	7-1
FRONT WHEELS	7-1
REAR WHEELS	7-2
WHEEL INSPECTION	7-3
WHEEL HUB INSPECTION	7-3
BRAKE DRUM INSPECTION	7-3
BRAKE DISK INSPECTION	7-4
WHEEL HUB/BRAKE DRUM INSTALLATION	7-4
WHEEL INSTALLATION	7-4
FRONT BRAKE	7-6
BRAKE PADS	7-6
BRAKE PAD REPLACEMENT	7-7
MASTER CYLINDER	7-9
MASTER CYLINDER INSPECTION	7-11
MASTER CYLINDER ASSEMBLY	7-11
MASTER CYLINDER INSTALLATION	7-12
BRAKE CALIPER	7-14
CALIPER DISASSEMBLY	7-16
CALIPER INSPECTION	7-16
CALIPER ASSEMBLY	7-17
CALIPER INSTALLATION	7-17
REAR BRAKE	7-19
BRAKE SHOE PLATE INSPECTION	7-21
BRAKE SHOE INSPECTION	7-21
BRAKE DRUM INSPECTION	7-22
REAR BRAKE ASSEMBLY	7-22
REAR BRAKE INSTALLATION	7-23
STEERING SYSTEM	7-24
HANDLEBAR	7-24
HANDLEBAR INSPECTION	7-26
HANDLEBAR INSTALLATION	7-26
REAR BRAKE LEVER INSTALLATION	7-26
MASTER CYLINDER ASSEMBLY INSTALLATION	7-26
STEERING STEM	7-27

BEARING RETAINER REMOVAL	7-29
STEERING STEM INSPECTION	7-29
BEARING, RETAINER INSTALLATION	7-29
CABLE GUIDE INSTALLATION	7-29
TIE-ROD AND STEERING KNUCKLE	7-30
STEERING KNUCKLE REMOVAL	7-31
TIE-ROD INSPECTION	7-31
STEERING KNUCKLE INSPECTION	7-31
BALL JOINT INSPECTION	7-32
TIE-ROD INSTALLATION	7-32
FRONT ARM AND FRONT SHOCK ABSORBER	7-33
FRONT ARM REMOVAL	7-34
FRONT ARM INSPECTION	7-34
FRONT SHOCK ABSORBER INSPECTION	7-34
FRONT ARM INSTALLATION	7-35
REAR SHOCK ABSORBER AND SWINGARM	7-36
SWINGARM REMOVAL	7-38
REAR SHOCK ABSORBER INSPECTION	7-38
SWINGARM INSPECTION	7-39
RUBBER BOOT INSPECTION	7-39
RUBBER BOOT INSTALLATION	7-39
SWINGARM INSTALLATION	7-40

CHAPTER 8. ELECTRICAL

ELECTRICAL COMPONENTS	8-1
SWITCH INSPECTION	8-2
SWITCH INSPECTION	8-2
INSPECTING A SWITCH SHOWN IN THE MANUAL	8-2
SWITCH CONTINUITY INSPECTION	8-3
IGNITION SYSTEM	8-5
CIRCUIT DIAGRAM	8-5
TROUBLESHOOTING	8-6
ELECTRIC STARTING SYSTEM	8-10
CIRCUIT DIAGRAM	8-10
STARTING CIRCUIT OPERATION	8-11
TROUBLESHOOTING	8-12
STARTER MOTOR.....	8-16
STARTER MOTOR INSPECTION	8-17
STARTER MOTOR ASSEMBLY	8-18



**GEN
INFO 1**



SPEC 2



**INSP
ADJ 3**



ENG 4



CARB 5



DRIVE 6



CHAS 7



ELEC 8



**TRBL
SHTG 9**









CHARGING SYSTEM	8-19
CIRCUIT DIAGRAM	8-19
TROUBLESHOOTING	8-20
LIGHTING SYSTEM	8-22
CIRCUIT DIAGRAM	8-22
TROUBLESHOOTING	8-23
LIGHTING SYSTEM CHECK	8-25
SIGNAL SYSTEM	8-27
CIRCUIT DIAGRAM	8-27
TROUBLESHOOTING	8-28
SIGNAL SYSTEM CHECK	8-30
COOLING SYSTEM	8-35
CIRCUIT DIAGRAM	8-35
TROUBLESHOOTING	8-36
2WD/4WD SELECTING SYSTEM	8-40
CIRCUIT DIAGRAM	8-40
TROUBLESHOOTING	8-41

CHAPTER 9. TROUBLESHOOTING

STARTING FAILURE/HARD STARTING	9-1
FUEL SYSTEM	9-1
ELECTRICAL SYSTEM	9-1
COMPRESSION SYSTEM	9-2
POOR IDLE SPEED PERFORMANCE	9-2
POOR IDLE SPEED PERFORMANCE	9-2
POOR MEDIUM AND HIGH SPEED PERFORMANCE	9-2
POOR MEDIUM AND HIGH SPEED PERFORMANCE	9-2
FAULTY DRIVE TRAIN	9-3
FAULTY GEAR SHIFTING	9-4
HARD SHIFTING	9-4
SHIFT LEVER DOES NOT MOVE	9-4
JUMPS-OUT-OF GEAR	9-4
FAULTY CLUTCH PERFORMANCE	9-4

ENGINE OPERATES BUT SCOOTER WILL NOT MOVE	9-4
CLUTCH SLIPPING	9-4
POOR STARTING PERFORMANCE.....	9-4
POOR SPEED PERFORMANCE	9-5
OVERHEATING	9-5
OVERHEATING	9-5
FAULTY BRAKE	9-5
POOR BRAKING EFFECT	9-5
SHOCK ABSORBER MALFUNCTION	9-6
MALFUNCTION	9-6
UNSTABLE HANDLING	9-6
UNSTABLE HANDLING	9-6
LIGHTING SYSTEM	9-6
HEADLIGHT DARK	9-6
BULB BURNT OUT	9-6

YFM600FWA WIRNING DIAGRAM

	GEN INFO	1
	SPEC	2
	INSP ADJ	3
	ENG	4
	CARB	5
	DRIVE	6
	CHAS	7
	ELEC	8
	TRBL SHTG	9

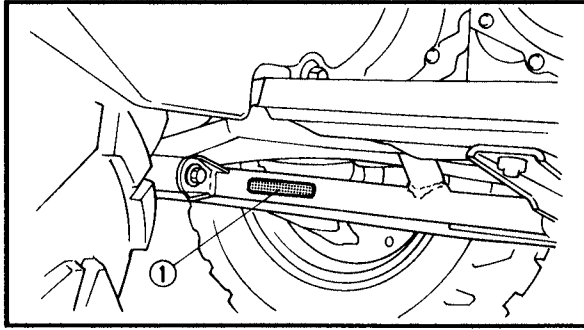

GENERAL INFORMATION
MACHINE IDENTIFICATION

VEHICLE IDENTIFICATION NUMBER

The vehicle identification number ① is stamped into the left side of the frame.

1

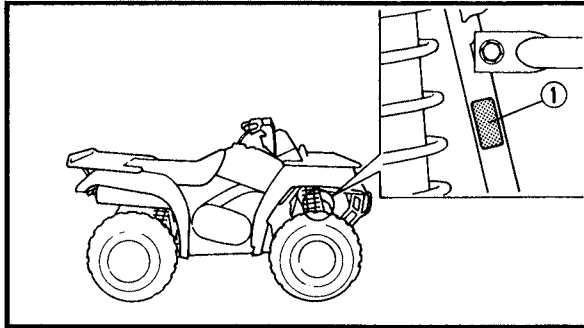

MODEL LABEL

The model label ① is affixed to the frame. This information will be needed to order spare parts.

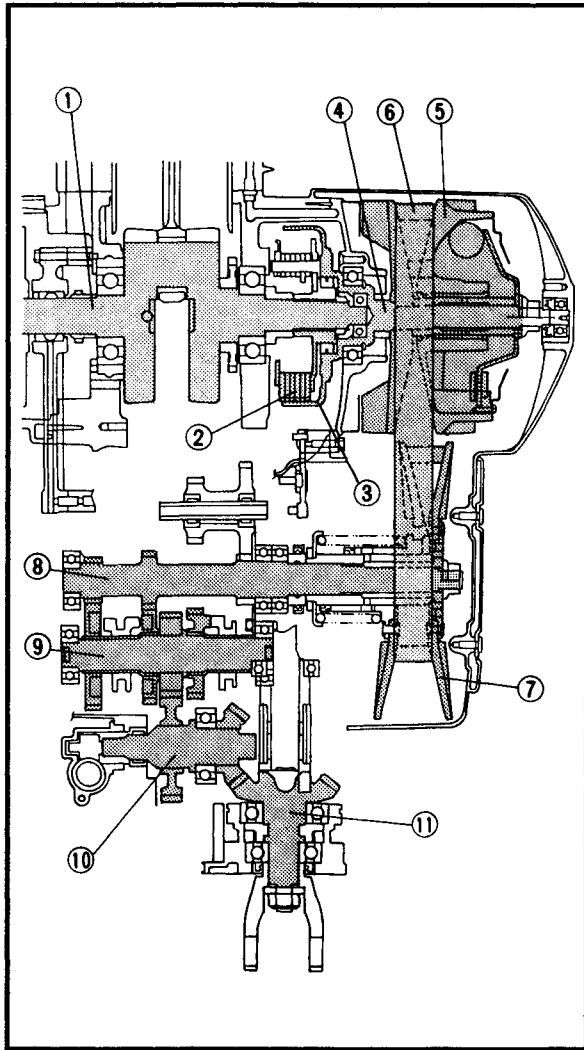

FEATURES

Transmission of power

The V-belt transmission system, combined with a high torque engine, allows easy and comfortable driving at all power ranges.

Power Transmission

- Crankshaft ①
- ↓
- Centrifugal clutch ②
- ↓
- Clutch housing ③
- ↓
- Sheave shaft ④
- ↓
- Primary sheave ⑤
- ↓
- V-belt ⑥
- ↓
- Secondary sheave ⑦
- ↓
- Main axle ⑧
- ↓
- Drive axle ⑨
- ↓
- Drive pinion gear shaft ⑩
- ↓
- Pinion driven gear shaft ⑪

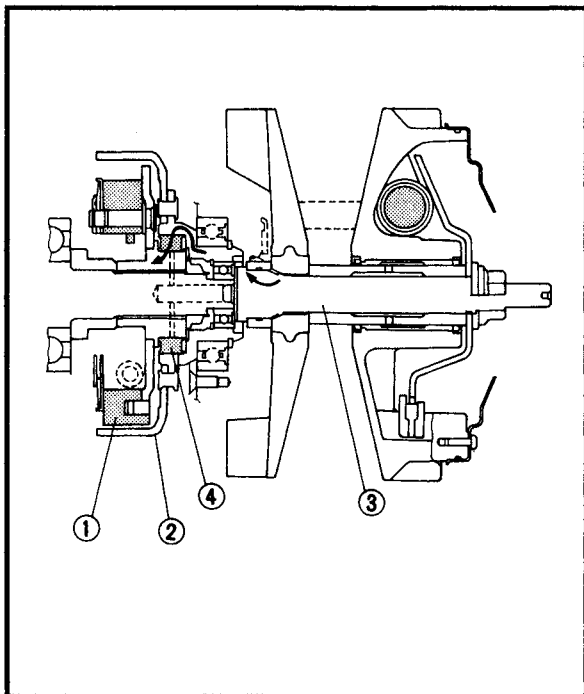

Clutch & Engine brake

The engine brake functions when the throttle lever is returned by the constant-contact type V-belt and one-way clutch.

Operation is as follows.

- a) When the engine speed reaches approximately 1,900 r/min, the centrifugal clutch ① presses against the clutch housing ② and the drive force is transmitted to the sheave shaft ③.
- b) During deceleration, when the engine speed is less than 1,900 r/min, the centrifugal clutch ① releases from the clutch housing ② and the one way clutch ④ continues to transmit braking force to the engine.

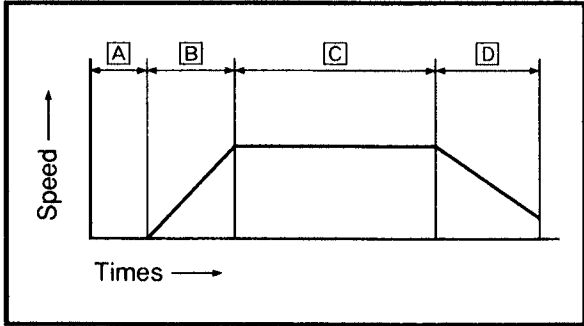

Explanation of Operation

- A Idling**
The centrifugal clutch is separated from the clutch housing, and no power is transmitted to the primary sheave.
- B Accelerating**
The centrifugal clutch comes in contact with the clutch housing, and power is transmitted to the primary sheave. The primary sheave (or secondary sheave) is in constant contact with the V-belt and transmits power.
- C Running at Constant Speed**
The centrifugal clutch is in contact with the clutch housing so power is transmitted.
- D Decelerating**
When the throttle lever is returned, the V-belt is always in contact with the sheave, so the inertia force of the wheels is transmitted to the engine, and the engine brake functions. Also, when the engine is running at less than 1900 r/min with the clutch in (for example, when idling and going down hill), the engine brake functions by way of the one-way clutch.

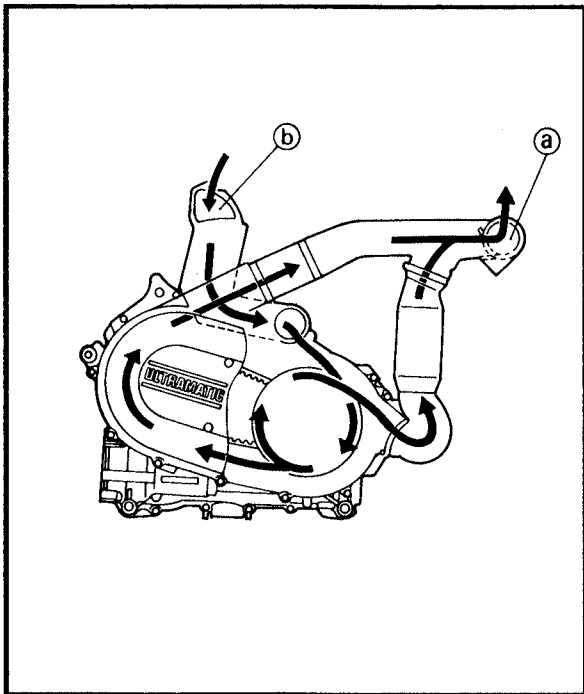

Cooling the V-belt Chamber

There are fins located around the outside of the primary sheave and they cool the inside of the V-belt chamber.

- Ⓐ Exhaust duct
- Ⓑ Intake duct

CAUTION:

Make sure that water, dirt, etc., do not get inside the chamber through ducts Ⓐ and Ⓑ.

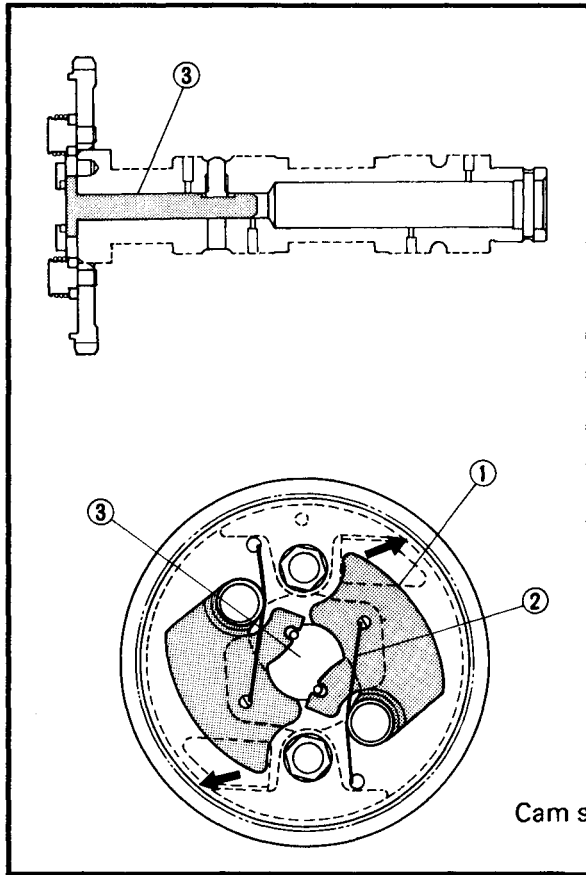

Auto-Decompression

Auto-Decompression of the centrifugal mechanism is used in this vehicle.

From approximately 0 ~ 700 r/min, the governor's weights ① are pulled inward by the springs ② and causes the decompression lever ③ to turn clockwise. As a result, the pin ④ in the decompression lever is forced up and the exhaust valve's rocker arm is pushed and compression is slightly released.

When engine revolution exceeds 700 r/min, the weights are forced out causing the decompression lever to turn counterclockwise. The pin is then forced down by the spring.

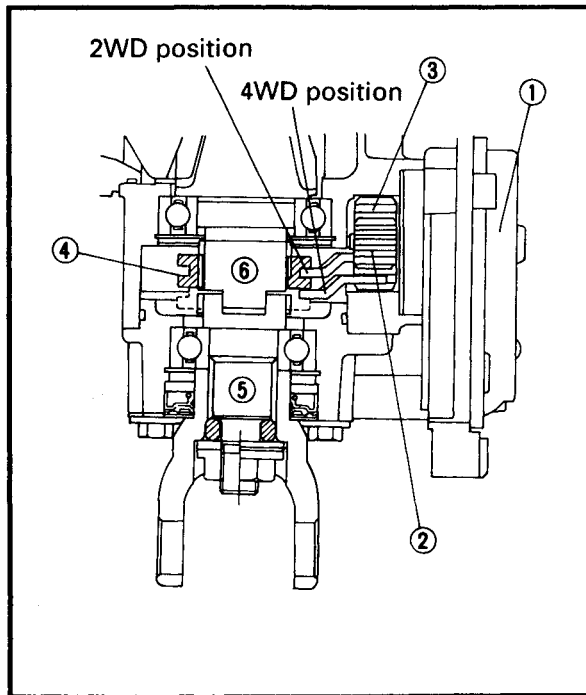
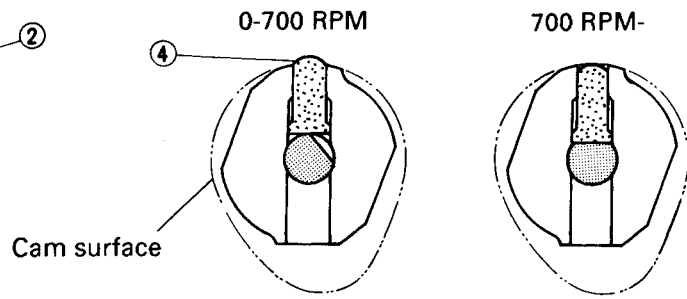

On command 4WD

When 4WD is selected using the 2WD/4WD select switch

The gear motor ① operates for approximately 1.5 second, the pinion gear ② turns and the shift fork sliding gear ③ moves approximately 8 mm (0.31 in.) together with the shift fork.

At this time, if the splines of the input shaft ⑤ and drive pinion gear ⑥ do not mesh, the 2WD/4WD shift sleeve ④ does not shift completely into 4WD and the 4WD indicator light does not light.

If the splines of the input shaft ⑤ and drive pinion gear ⑥ mesh, the 2WD/4WD shift sleeve ④ is shifted completely into 4WD by the force of the spring inside the gear motor and the 4WD indicator light lights.

Install the gear motor by the following method in order that the spring inside the

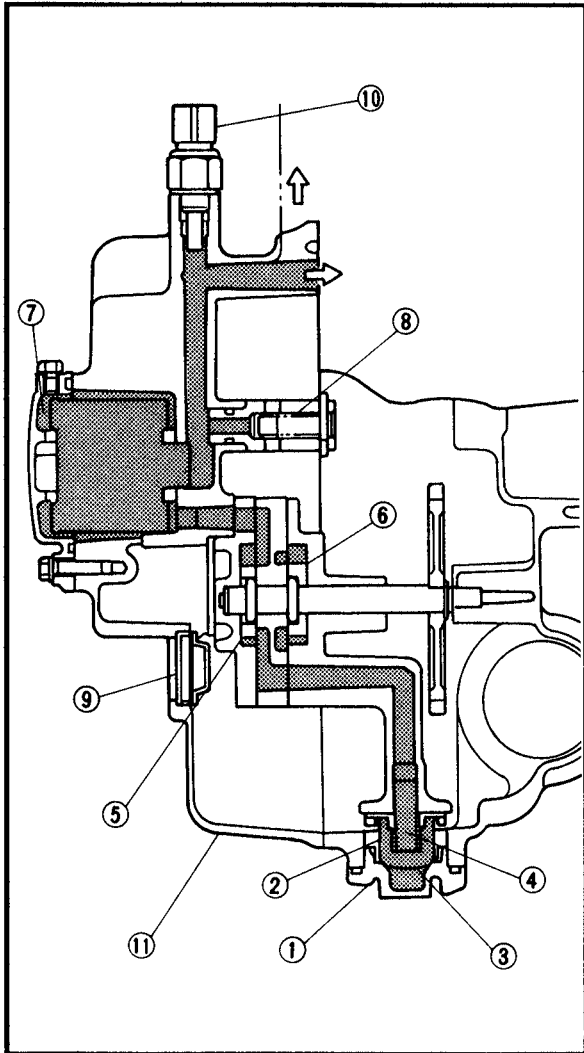
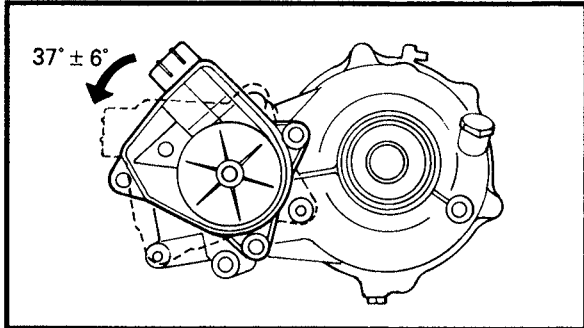
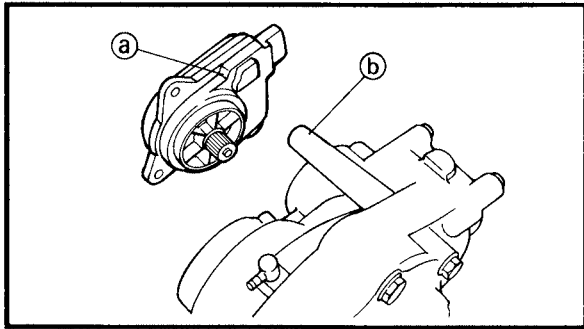

Gear motor installation steps

- 1) Apply lightweight lithium-soap base grease to the gear motor's O-ring.
- 2) Make sure the gear motor and shift fork sliding gear are in the 2WD position. If their position is not correct, position them in the 2WD position.
- 3) While aligning the gear motor's stopper (a) with the differential gear case's boss (b), mesh the pinion gear (gear motor) and shift fork sliding gear together.
- 4) Push the gear motor into the differential gear case.
- 5) Rotate the gear motor counterclockwise approximately $37^\circ \pm 6^\circ$ and align it with the gear motor's mounting hole. In this way, the initial load is applied to the spring inside the gear motor.
- 6) Fasten the gear motor with the bolt(s).

	<p>Bolt (gear motor): 13 Nm (1.3 m · kg, 9.4 ft · lb)</p>
---	--

Lubrication

A wet sump lubrication system is used. Two oil pump rotors are used independently for lubrication and for sending oil to the oil cooler.

- ① Plug
- ② Spring
- ③ Strainer
- ④ Pipe
- ⑤ Rotor for lubrication
- ⑥ Rotor for oil cooler
- ⑦ Oil filter
- ⑧ Relief valve
- ⑨ Oil level gauge
- ⑩ Thermo switch

NOTE: _____
 When disassembling the left side crankcase (11), remove the following parts to avoid obstructing the right side crankcase: plug (1), spring (2), strainer (3), and pipe (4).

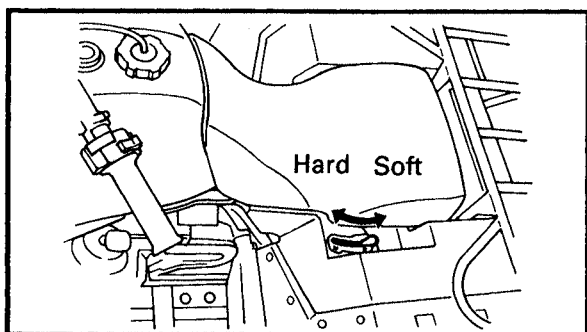

Rear shock absorber

The spring rate can be adjusted with the remote lever, which is connected to the spring rate adjuster with linkage.

NOTE:

The spring rate cannot be adjusted when the ATV is loaded.

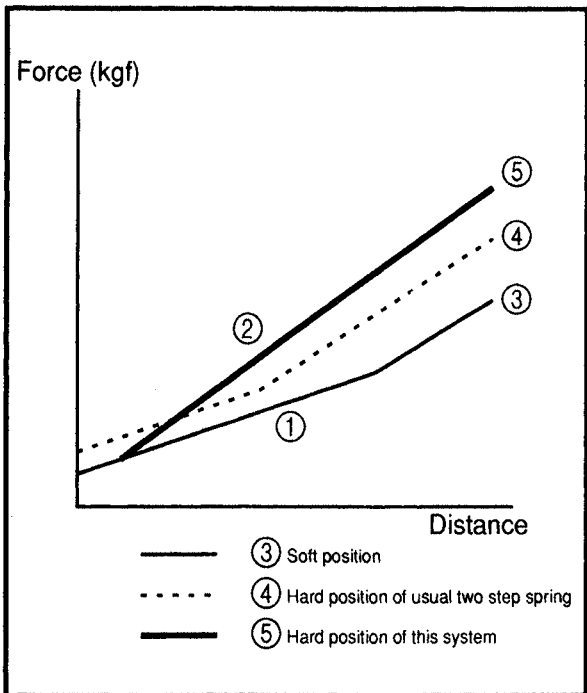

At the "Soft" position ①, the suspension operates with the combined spring rate of both springs. At the "Hard" position ②, the spacer ⑥ is moved down causing the upper spring to have a shorter stroke and the bottom spring is in full operation.

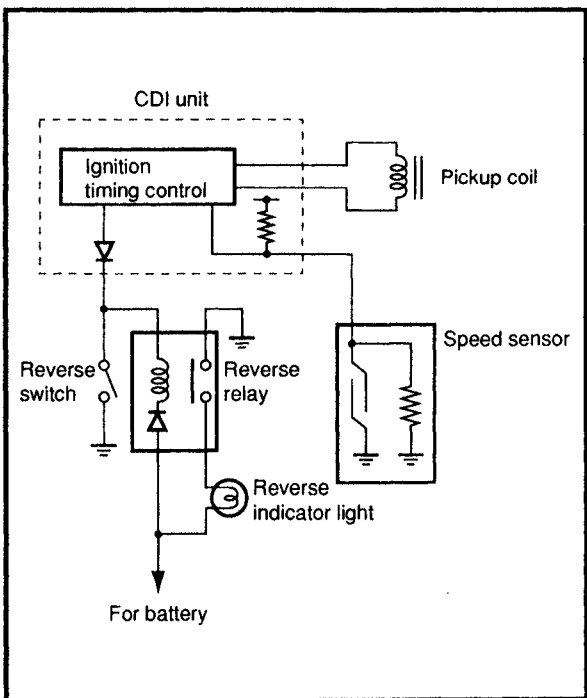
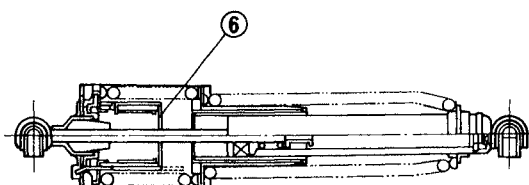

Revolution and Speed Limiter

This ATV is equipped with an engine speed control function.

- 1) Over-revolution limiter system
During normal operation (except in reverse), the engine speed will be kept below 7,800 r/min.
- 2) Speed limiter system
When the reverse indicator light comes on, the signal from the speed sensor is detected and the system is activated when the vehicle speed reaches 20 km/h. At this time, if the signal should not reach the CDI unit because the speed sensor is broken or the coupler is disconnected, the engine speed will be kept below 2,500 r/min.



EB101000

IMPORTANT INFORMATION
PREPARATION FOR REMOVAL
PROCEDURES

1. Remove all dirt, mud, dust and foreign material before removal and disassembly.
2. Use proper tools and cleaning equipment. Refer to the "SPECIAL TOOLS" section.
3. When disassembling the machine, always keep mated parts together. This includes gears, cylinder, piston and other parts that have been "mated" through normal wear. Mated parts must always be reused or replaced as an assembly.
4. During machine disassembly, clean all parts and place them in trays in the order of disassembly. This will speed up assembly and allow for the correct installation of all parts.
5. Keep all parts away from any source of fire.

EB101010

REPLACEMENT PARTS

1. Use only genuine Yamaha parts for all replacements. Use oil and grease recommended by Yamaha for all lubrication jobs. Other brands may be similar in function and appearance, but inferior in quality.

EB101020

GASKETS, OIL SEALS AND O-RINGS

1. Replace all gaskets, seals and O-rings when overhauling the engine. All gasket surfaces, oil seal lips and O-rings must be cleaned.
2. Properly oil all mating parts and bearings during reassembly. Apply grease to the oil seal lips.

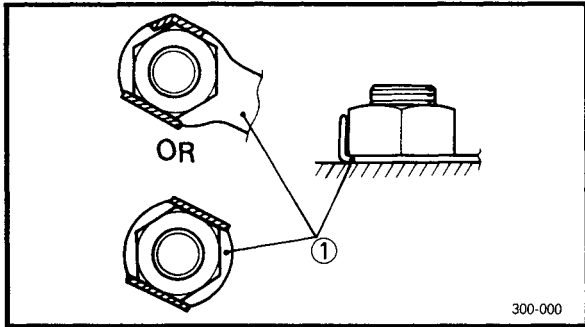

EB101030

LOCK WASHERS/PLATES AND COTTER PINS

1. Replace all lock washers/plates ① and cotter pins after removal. Bend lock tabs along the bolt or nut flats after the bolt or nut has been tightened to specification.

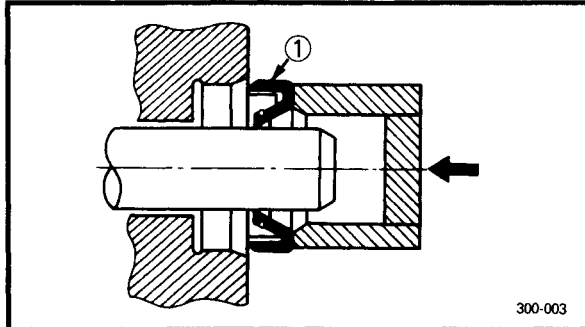

EB101040

BEARINGS AND OIL SEALS

1. Install bearings and oil seals so that the manufacturer's marks or numbers are visible. When installing oil seals, apply a light coating of lightweight lithium base grease to the seal lips. Oil bearings liberally when installing, if appropriate.

- ① Oil seal

CAUTION:

Do not use compressed air to spin the bearings dry. This will damage the bearing surfaces.

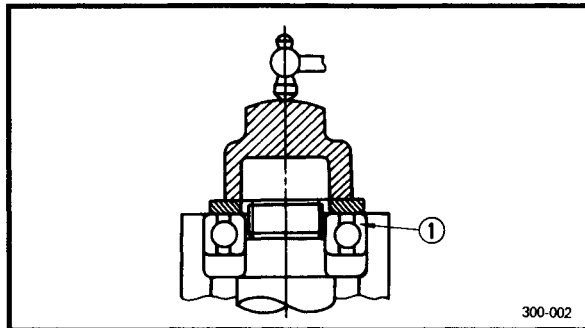

- ① Bearing

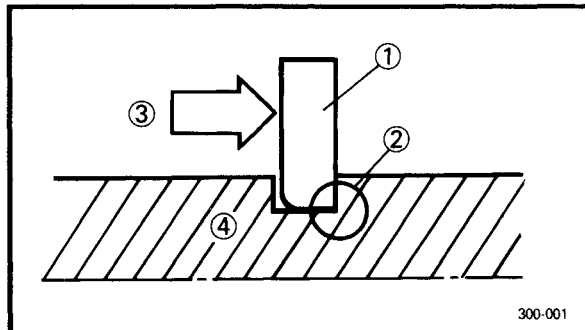

EB101050

CIRCLIPS

1. Check all circlips carefully before reassembly. Always replace piston pin clips after one use. Replace distorted circlips. When installing a circlip ①, make sure that the sharp-edged corner ② is positioned opposite the thrust ③ it receives. See sectional view.

- ④ Shaft

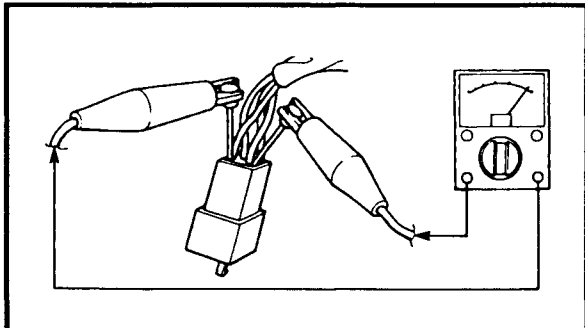
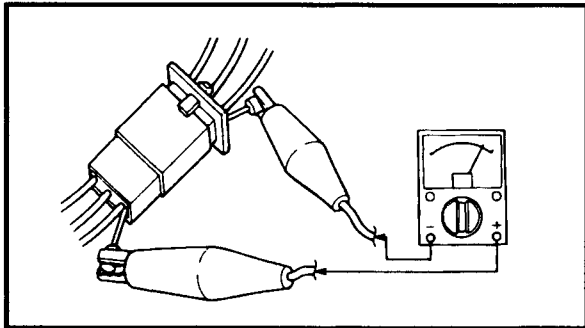
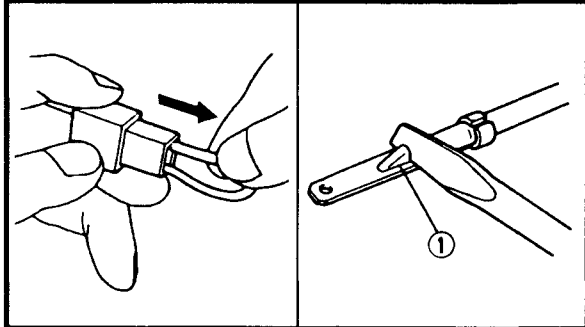
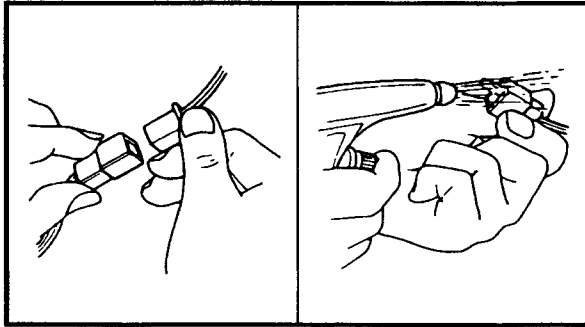

EB801000

CHECKING OF CONNECTIONS

Check the connectors for stains, rust, moisture, etc.

1. Disconnect:

- Connector

2. Check:

- Connector

Moisture → Dry each terminal with an air blower.

Stains/rust → Connect and disconnect the terminals several times.

3. Check:

- Connector leads

Looseness → Bend up the pin ① and connect the terminals.

4. Connect:

- Connector terminals

NOTE:

The two terminals "click" together.

5. Check:

- Continuity (using a pocket tester)

NOTE:

- If there is no continuity, clean the terminals.
- When checking the wire harness be sure to perform steps 1 to 3.
- As a quick remedy, use a contact revitalizer available at most part stores.
- Check the connector with a pocket tester as shown.

EB102001

SPECIAL TOOLS

The following special tools are necessary for complete and accurate tune-up and assembly. Use only the appropriate special tools; this will help prevent damage caused by the use of inappropriate tools or improvised techniques. Special tools may differ by shape and part number from country to country. In such a case, two types are provided.



When placing an order, refer to the list provided below to avoid any mistakes.



For US and CDN

P/N. YM-, YU-, YS-, YK-, ACC-

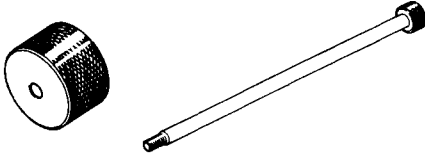
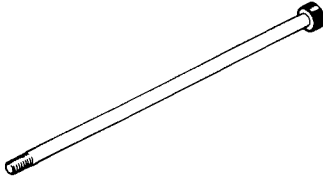
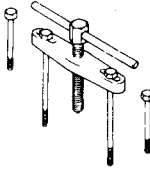

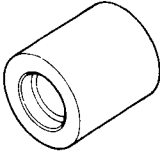
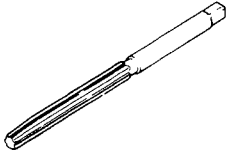
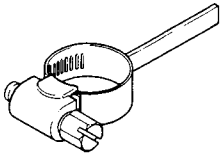
Except for US and CDN

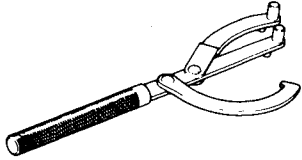
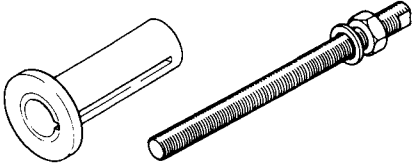
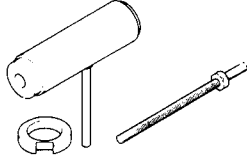
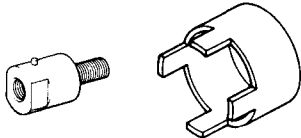
P/N. 90890-

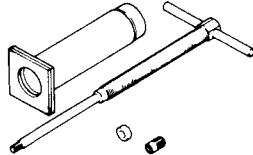
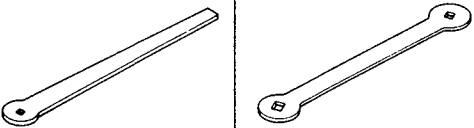
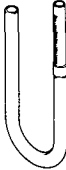
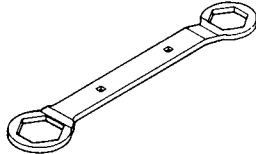
Tool No.	Tool name / How to use	Illustration
Bolt 90890-01083 Weight 90890-01084 Set YU-01083-A	Slide hammer bolt (M6) / weight / set These tools are used to remove the rocker arm shaft.	
90890-01085 YU-01083-2	Slide hammer bolt (M8) These tools are used to separate to the crankcase.	
90890-01135 YU-01135-A	Crankcase separating tool This tool is used to separate to the crankcase.	
90890-01225 YM-01225-A	Valve guide remover (7.0 mm) This tool is needed to remove and install the valve guide.	
90890-04017 YM-04017	Valve guide installer (7.0 mm) This tool is needed to install the valve guide.	
90890-01227 YM-01227	Valve guide reamer (7.0 mm) This tool is needed to rebores the new valve guide.	
90890-01231 YM-01231	Gear lash measurement tool This tool is used to measure the gear lash.	

Tool No.	Tool name / How to use	Illustration
90890-01235 YU-01235	<p>Rotor holding tool</p> <p>This tool is needed to hold the starter puller when removing / installing the starter puller bolt or camshaft sprocket bolts.</p>	
Pot 90890-01274 Bolt 90890-01275	<p>Crankshaft installer pot Crankshaft installer bolt</p> <p>These tools are used to install the crankshaft.</p>	
YU-90050	<p>Crankshaft installer set</p> <p>These tools are used to install the crankshaft.</p>	
Adapter 90890-01383 YM-01383 Spacer 90890-04081 YM-91044	<p>Adapter (M10) Spacer (crankshaft installer)</p> <p>These tools are used to install the crankshaft.</p>	
90890-01016	<p>Spacer</p> <p>This tool is used to install the crankshaft.</p>	
90890-01304 YU-01304	<p>Piston pin puller</p> <p>This tool is used to remove the piston pin.</p>	
90890-01311 YU-08035	<p>Tappet adjusting tool (3 mm)</p> <p>This tool is necessary for adjusting the valve clearance.</p>	
90890-01312 YM-01312-A	<p>Fuel level gauge</p> <p>This gauge is used to measure the fuel level in the float chamber.</p>	
90890-01348	<p>Locknut wrench</p> <p>This tool is needed when removing or installing the secondary sheave spring.</p>	

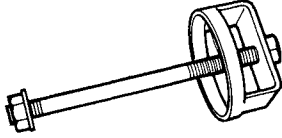
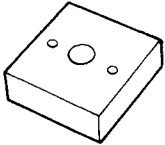
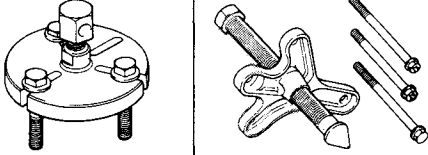

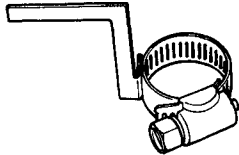
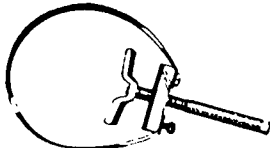
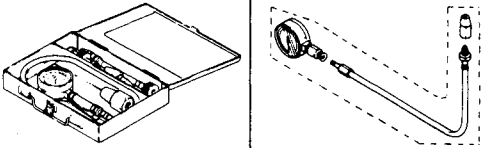
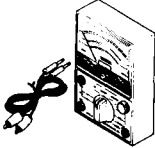
Tool No.	Tool name / How to use	Illustration
90890-04134 YM-04134	Sheave spring compressor This tool is needed when removing or installing the secondary sheave spring.	
90890-04135 YM-04135	Sheave fixed block This tool is needed when removing or installing the secondary sheave spring.	
90890-01362 YU-33270	Flywheel puller These tools are needed to remove the rotor.	
90890-01375	Damper rod holder (29 mm) This tool is needed to loosen and tighten the steering stem bearing retainer.	
90890-01430 YM-38404	Ring nut wrench This tool is needed to removing and installing the middle driven shaft bearing retainer.	
90890-01467 YM-01467	Gear lash measurement tool This tool is used to measure the gear lash.	
90890-01701 YU-01880	Sheave holder This tool is needed to hold the primary sheave when removing or installing the sheave bolts.	
Set 90890-03081 YU-33223 Adapter 90890-04082 YU-33223-3	Compression gauge set Adapter These tools are needed to measure engine compression.	
90890-03112 YU-03112	Pocket tester This instrument is needed for checking the electrical system.	

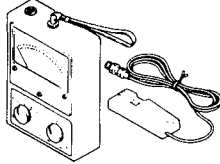
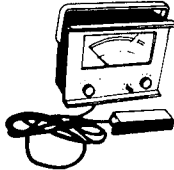
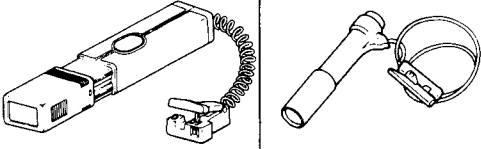
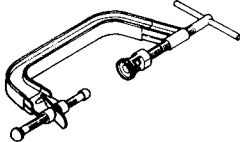
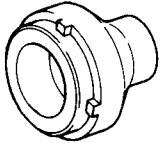
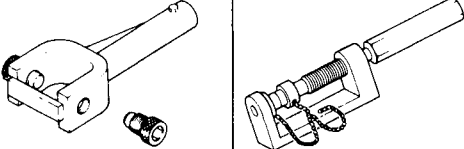
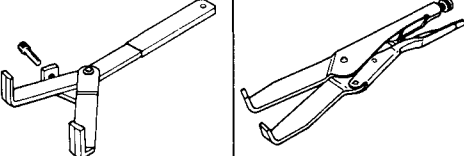
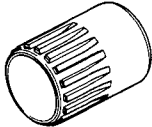
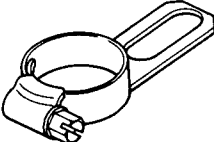
Tool No.	Tool name / How to use	Illustration	
90890-03113	<p>Engine tachometer</p> <p>This tool is needed for observing engine rpm.</p>		
YU-8036-1	<p>Inductive tachometer</p> <p>This tool is needed for observing engine rpm.</p>		
90890-03141 YM-33277-A	<p>Timing light</p> <p>This tool is necessary for checking ignition timing.</p>		
90890-04019 YM-04019	<p>Valve spring compressor</p> <p>This tool is needed to remove and install the valve assemblies.</p>		
90890-04050 YM-04050	<p>Bearing retainer wrench</p> <p>This tool is needed when removing or installing the final drive shaft bearing retainer.</p>		
90890-04062 YM-04062	<p>Universal joint holder</p> <p>This tool is needed when removing or installing the universal joint yoke nut.</p>		
90890-04086 YM-91042	<p>Clutch holding tool</p> <p>This tool is needed to hold the clutch carrier when removing or installing the carrier nut.</p>		
90890-04128 YM-04128	<p>Bearing retainer wrench</p> <p>This tool is needed when removing or installing the middle driven pinion gear bearing retainer.</p>		
90890-04129 YM-04129	<p>Pinion gear fix clamp</p> <p>This tool is used to hold the shift cam.</p>		

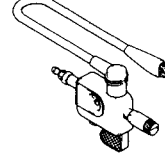
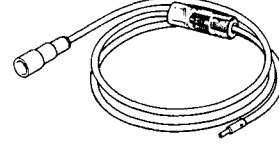
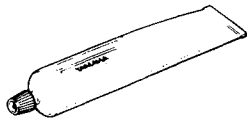
Tool No.	Tool name / How to use	Illustration
90890-06754	<p>Ignition checker</p> <p>This instrument is necessary for checking the ignition system components.</p>	
YM-34487	<p>Dynamic spark tester</p> <p>This instrument is necessary for checking the ignition system components.</p>	
<p>Bont 90890-85505 Sealant ACC-11001-05-01</p>	<p>Yamaha bond No. 1215 Sealant (Quick Gasket®)</p> <p>This sealant (bond) is used on crank-case mating surfaces, etc.</p>	



SPECIFICATIONS

GENERAL SPECIFICATIONS

Item	Standard
Model code:	4WV1 : USA 4WV2 : CDN
Dimensions:	
Overall length	2,079 mm (81.9 in)
Overall width	1,161 mm (45.7 in)
Overall height	1,215 mm (47.8 in)
Seat height	865 mm (34.1 in)
Wheelbase	1,254 mm (49.3 in)
Minimum ground clearance	178 mm (25.4 in)
Minimum turning radius	3,100 mm (122 in)
Basic weight:	
With oil and full fuel tank	307 kg (139 lb)
Engine:	
Engine type	Air-cooled 4-stroke, SOHC
Cylinder arrangement	Forward-inclined single cylinder
Displacement	595 cm ³
Bore × stroke	95 × 84 mm (3.74 × 3.31 in)
Compression ratio	8.5 :1
Starting system	Electric and recoil starter
Lubrication system:	Wet sump
Oil type or grade:	
Engine oil	
Final gear oil	SAE80API "GL-4" Hypoid Gear Oil
Differential gear oil	SAE80API "GL-4" Hypoid Gear Oil
Oil capacity:	
Engine oil	
Periodic oil change	1.9 L (1.67 Imp qt, 2.0 US qt)
With oil filter replacement	2 L (1.67 Imp qt, 2.1 US qt)
Total amount	2.6 L (2.29 Imp qt, 2.7 US qt)
Final gear case oil	
Periodic oil change	0.19 L (0.17 Imp qt, 0.20 US qt)
Total amount	0.22 L (0.20 Imp qt, 0.23 US qt)
Differential gear case oil	
Periodic oil change	0.67 L (0.59 Imp qt, 0.71 US qt)
Total amount	0.7 L (0.62 Imp qt, 0.74 US qt)
Oil cooler capacity (including all routes)	0.23 L (0.20 Imp qt, 0.24 US qt)

GENERAL SPECIFICATIONS

SPEC



Item	Standard
Air filter:	Wet type element
Fuel:	
Type	Regular gasoline
Fuel tank capacity	19 L (16.7 Imp qt, 20 US qt)
Fuel reserve amount	3 L (2.64 Imp qt, 3.2 US qt)
Carburetor:	
Type / quantity	BST40/1
Manufacturer	MIKUNI
Spark plug:	
Type	DP8EA-9 : USA DPR8EA-9 : CDN
Manufacturer	NGK
Spark plug gap	0.8 ~ 0.9 mm (0.031 ~ 0.035 in)
Clutch type	Wet, centrifugal automatic
Transmission:	
Primary reduction system	V-belt
Secondary reduction system	Spur gear
Secondary reduction ratio	34/25 × 24/18 × 33/9 (6.649)
Transmission type	Single speed automatic (V-belt type)
Operation	Left hand operation
Single speed automatic	2.45 ~ 0.70
Sub transmission ratio	low 38/14 (2.714) high 30/16 (1.875)
Reverse gear	30/13 × 27/19 (3.279)
Chassis:	
Frame type	Steel tube frame
Frame type	Pressed and steel tube frame
Caster angle	3°
Camber angle	1°
Kingpin angle	14°
Kingpin offset	0 mm (0 in)
Trail	15.5 mm (0.61 in)
Tread (STD)	rear 858 mm (33.8 in)
Tread (STD)	front 874 mm (34.4 in)
Toe-in	- 5 ~ 5 mm (-0.20 ~ 0.20 in)
Tire:	
Type	Tubeless
Size	front AT25x8-12 rear AT25x10-10
Manufacturer	front DUNLOP rear DUNLOP
Type	front KT-122 rear KT-126

GENERAL SPECIFICATIONS

SPEC



Item	Standard
Tire pressure (cold tire): Maximum load-except motorcycle Off-road riding	220 kg (485 lb) 27 ~ 33 kPa (0.27 ~ 0.33 kg/cm ² , 3.8 ~ 4.7 psi) 24.5 ~ 30.5 kPa (0.245 ~ 0.305 kg/cm ² , 3.5 ~ 4.3 psi)
Brake: Front brake Rear brake	type operation type operation Dual disc brake Right hand operation Drum brake Left hand and right foot operation
Suspension: Front suspension Rear suspension	Strut Swingarm (monocross)
Shock absorber: Front shock absorber Rear shock absorber	Coil spring / oil damper Coil spring / oil damper
Wheel travel: Front wheel travel Rear wheel travel	160 mm (6.30 in) 190 mm (7.48 in)
Electrical: Ignition system Generator system Battery type Battery capacity	C.D.I. A.C. magneto YTX20L-BS 12 V 18 AH
Headlight type:	Krypton bulb
Bulb wattage × quantity: Headlight Tail / brake light Meter light Indicator lights: Neutral Reverse Oil temperature 4WD	12 V 30 W/ 30 W × 2 12 V 7.5 W × 1 12 V 1.7 W × 1 12 V 1.7 W × 1 12 V 1.7 W × 1 12 V 3.4 W × 1 12 V 3.4 W × 1

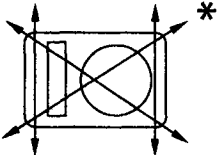
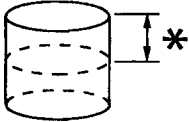
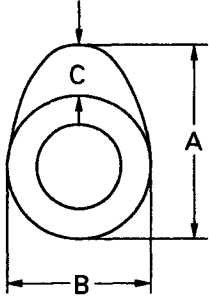

**MAINTENANCE SPECIFICATIONS
ENGINE**

Item	Standard	Limit
Cylinder head: Warp limit 	0.03 mm (0.0012 in)	0.10 mm (0.004 in)
Cylinder: Bore size Measuring point *  Out of round limit	94.97 ~ 95.02 mm (3.739 ~ 3.741 in) 40 mm (1.6 in) ----	95.1 mm (3.744 in) ---- 0.01 mm (0.0004 in)
Camshaft: Drive method Cam cap inside diameter Camshaft outside diameter Shaft-to-cap clearance Cam dimensions  Intake "A" "B" "C" Exhaust "A" "B" "C"	Chain drive (Left) 23.000 ~ 23.021 mm (0.9055 ~ 0.9063 in) 22.967 ~ 22.980 mm (0.9042 ~ 0.9047 in) 0.020 ~ 0.054 mm (0.0008 ~ 0.0021 in) 36.47 ~ 36.57 mm (1.436 ~ 1.440 in) 30.06 ~ 30.16 mm (1.183 ~ 1.187 in) 6.37 ~ 6.67 mm (0.251 ~ 0.263 in) 36.62 ~ 36.72 mm (1.442 ~ 1.446 in) 30.11 ~ 30.16 mm (1.185 ~ 1.187 in) 6.52 ~ 6.82 mm (0.257 ~ 0.269 in)	---- ---- ---- ---- 36.37 mm (1.433 in) 29.96 mm (1.180 in) ---- 36.52 mm (1.438 in) 30.01 mm (1.181 in) ----

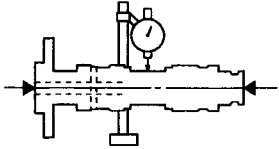
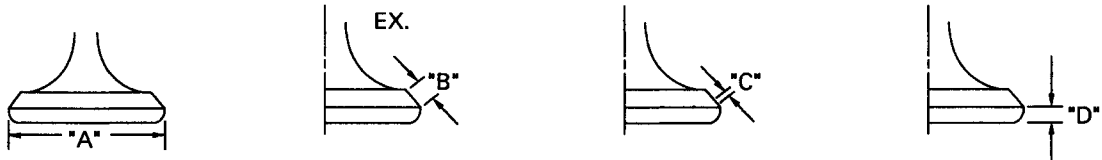

Item	Standard	Limit
Camshaft runout limit 	----	0.03 mm (0.0012 in)
Cam chain: Cam chain type / No. of links Cam chain adjustment method	75RH2015J/126 Automatic	---- ----
Rocker arm / rocker arm shaft: Shaft outside diameter Arm-to-shaft clearance	11.985 ~ 11.991 mm (0.4719 ~ 0.4721 in) 0.009 ~ 0.033 mm (0.0004 ~ 0.0013 in)	---- ----
Valve, valve seat, valve guide: Valve clearance (cold)	IN 0.05 ~ 0.10 mm (0.002 ~ 0.004 in) EX 0.12 ~ 0.17 mm (0.005 ~ 0.007 in)	---- ----
Valve dimensions: 		
Head Dia "A" head diameter	IN EX	36.9 ~ 37.1 mm (1.453 ~ 1.461 in) 31.9 ~ 32.1 mm (1.256 ~ 1.264 in)
Face Width "B" face width	IN EX	2.26 mm (0.089 in) 2.26 mm (0.089 in)
Seat Width "C" seat width	IN EX	1.0 ~ 1.2 mm (0.039 ~ 0.047 in) 1.0 ~ 1.2 mm (0.039 ~ 0.047 in)
Margin Thickness "D" margin thickness	IN EX	1.6 mm (0.063 in) 1.6 mm (0.063 in) 1.2 mm (0.047 in) 1.0 mm (0.039 in)
Stem outside diameter	IN EX	6.975 ~ 7.025 mm (0.2746 ~ 0.2766 in) 6.975 ~ 7.025 mm (0.2746 ~ 0.2766 in)
Guide inside diameter	IN EX	6.495 ~ 6.505 mm (0.2557 ~ 0.2561 in) 6.495 ~ 6.505 mm (0.2557 ~ 0.2561 in)

MAINTENANCE SPECIFICATIONS

SPEC

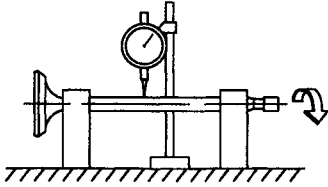
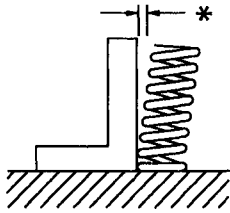

Item		Standard	Limit
Stem-to-guide clearance	IN	0.010 ~ 0.037 mm (0.0004 ~ 0.0015 in)	0.08 mm (0.003 in)
	EX	0.030 ~ 0.057 mm (0.0012 ~ 0.0022 in)	0.10 mm (0.004 in)
Stem runout limit		----	0.01 mm (0.0004 in)
			
Valve seat width	IN	1.1 mm (0.043 in)	----
	EX	1.1 mm (0.043 in)	----
Valve spring:			
Inner spring:			
Free length	IN	40.1 mm (1.58 in)	38.1 mm (1.50 in)
	EX	40.1 mm (1.58 in)	38.1 mm (1.50 in)
Set length (valve closed)	IN	31.2 mm (1.23 in)	----
	EX	31.2 mm (1.23 in)	----
Compressed pressure (installed)	IN	73 ~ 89 N (7.3 ~ 8.9 kg, 16.1 ~ 19.2 lb)	----
	EX	73 ~ 89 N (7.3 ~ 8.9 kg, 16.1 ~ 19.2 lb)	----
Tilt limit *	IN		2.5°/ 1.7 mm (2.5°/0.067 in)
	EX		2.5°/ 1.7 mm (2.5°/0.067 in)
			
Direction of winding (top view)			
	IN	Counterclockwise	----
	EX	Counterclockwise	----
Outer spring:			
Free length	IN	43.8 mm (1.72 in)	41.6 mm (1.64 in)
	EX	43.8 mm (1.72 in)	41.6 mm (1.64 in)
Set length (valve closed)	IN	34.2 mm (1.35 in)	----
	EX	34.2 mm (1.35 in)	----

MAINTENANCE SPECIFICATIONS

SPEC

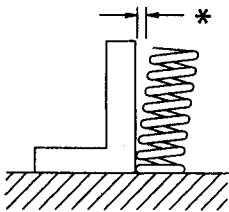
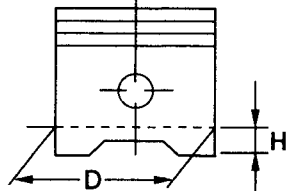
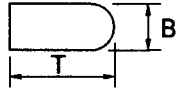

Item		Standard	Limit	
<p>Compressed pressure (installed)</p> <p style="text-align: right;">IN</p> <p style="text-align: right;">EX</p> <p>Tilt limit *</p> <p style="text-align: right;">IN</p> <p style="text-align: right;">EX</p> <div style="text-align: center;">  </div> <p>Direction of winding (top view)</p> <p style="text-align: right;">IN</p> <p style="text-align: right;">EX</p>		<p>152 ~ 186 N (15.2 ~ 18.6 kg, 33.5 ~ 41.0 lb)</p> <p>152 ~ 186 N (15.2 ~ 18.6 kg, 33.5 ~ 41.0 lb)</p>	<p>----</p> <p>----</p> <p>2.5°/1.9 mm (2.5°/0.075 in)</p> <p>2.5°/1.9 mm (2.5°/0.075 in)</p> <p>----</p> <p>----</p>	
	<p>Piston:</p> <p>Piston to cylinder clearance</p> <p>Piston size "D"</p> <div style="text-align: center;">  </div> <p>Measuring point "H"</p> <p>Piston off-set</p> <p>Piston pin bore inside diameter</p> <p>Piston pin outside diameter</p>		<p>0.045 ~ 0.065 mm (0.0018 ~ 0.0026 in)</p> <p>94.915 ~ 94.965 mm (3.737 ~ 3.739 in)</p>	<p>0.15 mm (0.0059 in)</p> <p>----</p>
			<p>5 mm (0.20 in)</p> <p>2 mm (0.08 in)</p> <p>22.004 ~ 22.015 mm (0.8663 ~ 0.8667 in)</p> <p>21.991 ~ 22.000 mm (0.8658 ~ 0.8661 in)</p>	<p>----</p> <p>----</p> <p>----</p> <p>----</p>
	<p>Piston rings:</p> <p>Top ring:</p> <div style="text-align: center;">  </div> <p>Type</p> <p>Dimensions (B × T)</p> <p>End gap (installed)</p> <p>Side clearance (installed)</p>		<p>Barrel</p> <p>1.2 × 3.8 mm (0.047 × 0.150 in)</p> <p>0.30 ~ 0.45 mm (0.012 ~ 0.018 in)</p> <p>0.04 ~ 0.08 mm (0.001 ~ 0.003 in)</p>	<p>----</p> <p>----</p> <p>0.7 mm (0.028 in)</p> <p>0.13 mm (0.005 in)</p>

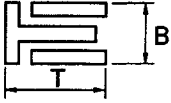
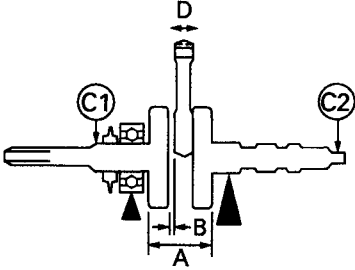

Item	Standard	Limit
<p>2nd ring:</p>  <p>Type Dimensions (B × T) End gap (installed) Side clearance</p> <p>Oil ring:</p>  <p>Dimensions (B × T) End gap (installed)</p>	<p>Plain 1.2 × 3.8 mm (0.047 ~ 0.150 in) 0.30 ~ 0.45 mm (0.012 ~ 0.018 in) 0.03 ~ 0.07 mm (0.001 ~ 0.002 in) 2.5 × 3.4 mm (0.098 ~ 0.134 in) 0.2 ~ 0.7 mm (0.008 ~ 0.028 in)</p>	<p>---- ---- 0.8 mm (0.031 in) 0.13 mm (0.005 in) ---- ----</p>
<p>Crankshaft:</p>  <p>Crank width "A" Runout limit C1 C2 Big end side clearance "D" Big end radial clearance "E" Small end free play "F"</p>	<p>74.95 ~ 75.00 mm (2.951 ~ 2.953 in) ---- ---- 0.35 ~ 0.65 mm (0.014 ~ 0.026 in) 0.010 ~ 0.025 mm (0.0004 ~ 0.0010 in) 0.8 mm (0.0315 in)</p>	<p>---- 0.03 mm (0.0012 in) 0.03 mm (0.0012 in) 1.0 mm (0.040 in) ---- ----</p>
<p>Balancer: Balancer drive method</p>	<p>Gear</p>	<p>----</p>
<p>Shifter: Shifter type</p>	<p>Cam drum and guide bar</p>	<p>----</p>
<p>Decompression device: Type</p>	<p>Auto decomp</p>	<p>----</p>
<p>Air filter oil grade:</p>	<p>Engine oil</p>	<p>----</p>

MAINTENANCE SPECIFICATIONS

SPEC



Item	Standard	Limit
Carburetor:		
I. D. mark	4WV 00	----
Main jet (M.J)	#145	----
Main air jet (M.A.J)	0.6	----
Jet needle (J.N)	6HH23-94-3	----
Needle jet (N.J)	Y-0M (#782)	----
Pilot air jet (P.A.J.1)	0.7	----
Pilot air jet (P.A.J.2)	1.0	----
Pilot outlet (P.O)	1.1	----
Pilot jet (P.J)	#42.5	----
Bypass 1 (B.P.1)	1.0	----
Bypass 2 (B.P.2)	0.8	----
Bypass 3 (B.P.3)	0.8	----
Pilot screw (P.S)	3 1/2	----
Valve seat size (V.S)	2.8	----
Starter jet (G.S.1)	#100	----
Throttle valve size (Th.V)	#110	----
Float height (F.H)	14.7 mm (0.59 in)	----
Fuel level (F.L)	2 ~ 3 mm (0.08 ~ 0.12 in)	----
Engine idle speed	1.350 ~ 1.450 r/min	----
Intake vacuum	30.8 kPa (231 mmHg, 9.09 inHg)	----
Lubrication system:		
Oil filter type	Paper type	----
Oil pump type	Trochoid type	----
Tip clearance "A" or "B"	0.09 ~ 0.15 mm (0.004 ~ 0.006 in)	0.23 mm (0.009 in)
Side clearance	0.03 ~ 0.08 mm (0.001 ~ 0.003 in)	0.15 mm (0.006 in)
Bypass valve setting pressure	40 ~ 80 kPa (0.4 ~ 0.8 kg/cm ² , 5.69 ~ 11.38 psi)	----
Relief valve operating pressure	350 ~ 450 kPa (3.5 ~ 4.5 kg/cm ² , 49.8 ~ 64.0 psi)	----
Shaft drive:		
Middle gear backlash	0.1 ~ 0.3 mm (0.004 ~ 0.012 in)	----
Final gear backlash	0.1 ~ 0.2 mm (0.004 ~ 0.008 in)	----
Differential gear backlash	0.05 ~ 0.25 mm (0.002 ~ 0.010 in)	----

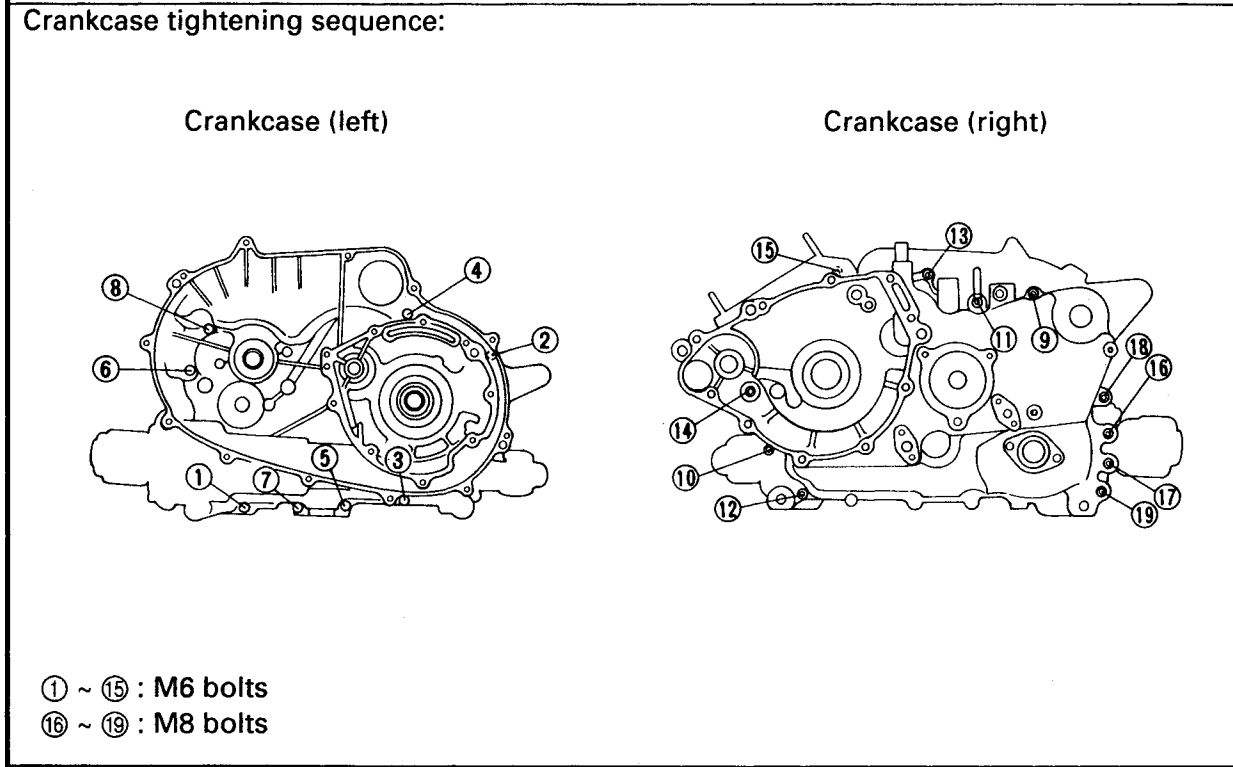
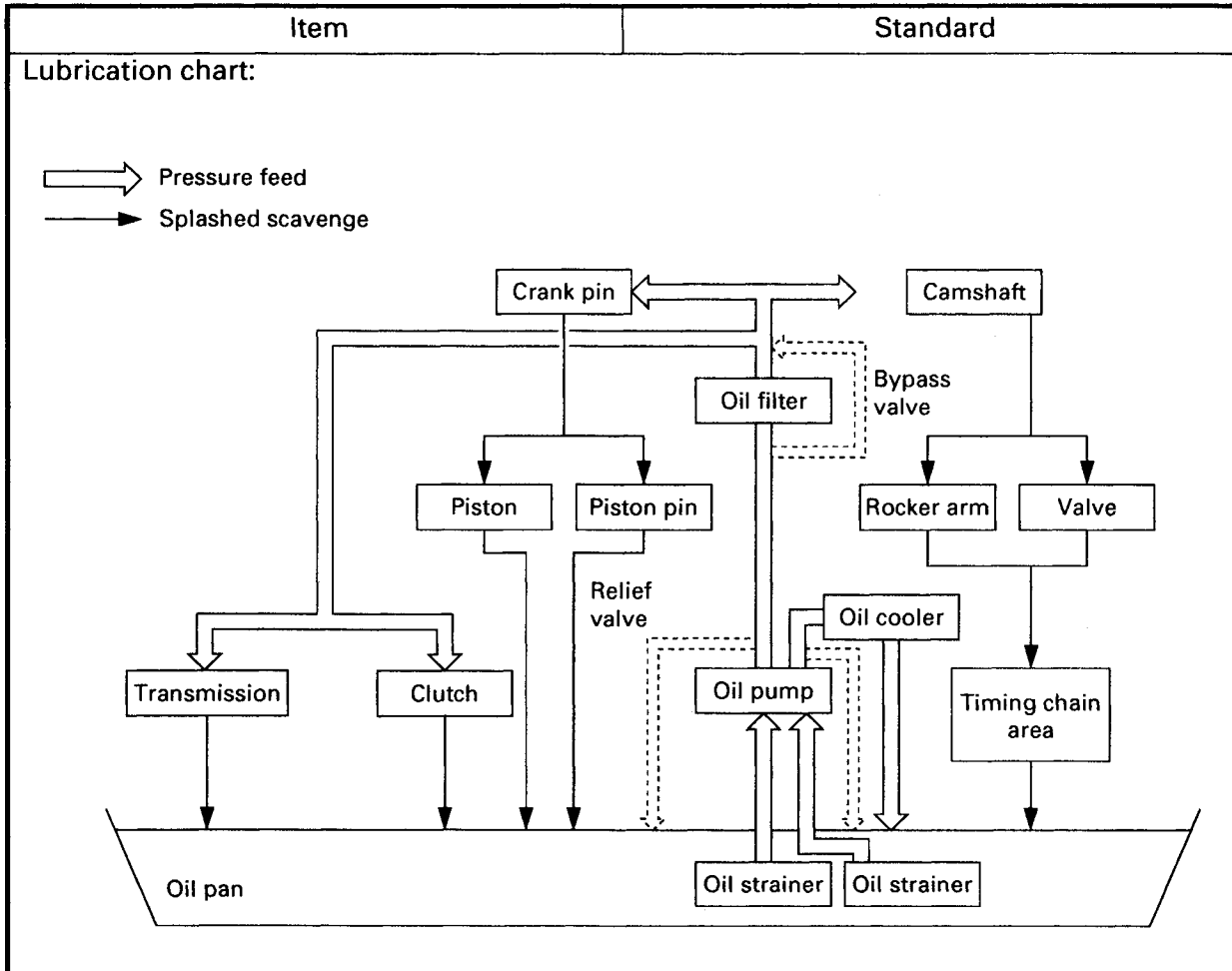

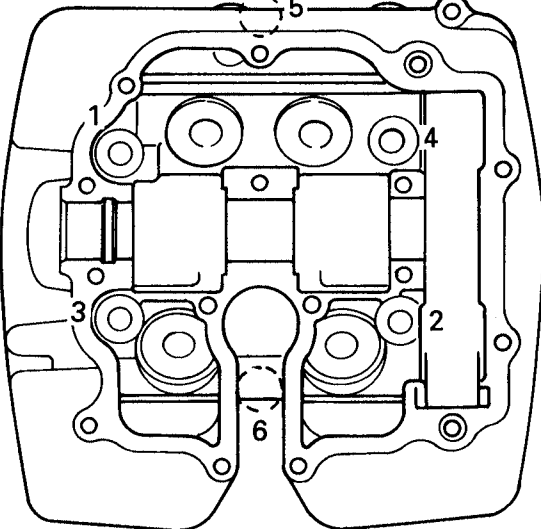

Item	Standard
<p data-bbox="203 247 673 283">Cylinder head tightening sequence:</p> 	



Tightening torques

Part to be tightened	Part name	Thread size	Q'ty	Tightening torque			Remarks
				Nm	m.kg	ft.lb	
Cylinder head (exhaust pipe)	Stud bolt	M6	4	7	0.7	5.1	
Cylinder head	Bolt	M8	4	29	2.9	21	
	Bolt	M6	1	10	1.0	7.2	
	Stud bolt	M10	2	20	2.0	14	
Spark plug	Nut	M8	2	22	2.2	16	
	—	M12	1	18	1.8	13	
Cylinder	Bolt	M6	1	10	1.0	7.2	
	Nut	M10	4	42	4.2	30	
Starter pullery	Bolt	M10	1	50	5.0	36	
Camshaft sprocket	Bolt	M7	2	20	2.0	14	
Timing chain tensioner cap	Bolt	M16	1	20	2.0	14	
Timing chain tensioner	Bolt	M6	2	10	1.0	7.2	
Timing chain guide (intake)	Bolt	M6	2	10	1.0	7.2	
Rocker arm shaft stopper	Bolt	M6	2	10	1.0	7.2	
Valve adjusting screw	Nut	M6	4	14	1.4	10	
Oil pump assembly	Bolt	M6	3	10	1.0	7.2	
Oil pump	Screw	M6	1	7	0.7	5.1	
Oil drain plug	Plug	M35	1	32	3.2	23	
	Plug	M14	1	23	2.3	17	
Oil filter cover	Bolt	M6	3	10	1.0	7.2	
Oil cooler hose	Nut	M22	2	35	3.5	25	
Oil cooler	Bolt	M6	2	7	0.7	5.1	
Fan	Bolt	M6	3	8	0.8	5.8	
Carburetor joint	Bolt	M6	4	10	1.0	7.2	
Air duct 2	Bolt	M6	1	8	0.8	5.8	
Muffler and exhaust pipe	Bolt	M8	1	20	2.0	14	
Muffler and pipe	Bolt	M6	1	8	0.8	5.8	
Muffler protector 1	Bolt	M6	6	11	1.1	8.0	
Muffler protector 2	Bolt	M6	4	14	1.4	10	
Exhaust pipe protector	Bolt	M6	3	14	1.4	10	
Exhaust pipe	Nut	M6	4	12	1.2	8.7	
Muffler	Bolt	M8	2	26	2.6	19	
Bearing retainer (crankcase)	Screw	M6	3	7	0.7	5.1	
Crankcase	Bolt	M8	4	31	3.1	22	
	Bolt	M6	15	10	1.0	7.2	
	Stud bolt	M10	4	20	2.0	14	
Clutch housing cover protector	Screw	M6	3	7	0.7	5.1	
Clutch carrier assembly	Nut	M22	1	140	14	100	Stake
Middle drive shaft bearing retainer	Torx screw	M8	4	29	2.9	21	
Middle driven shaft drive pinion gear	Nut	M22	1	145	14.5	105	Stake
Middle drive shaft bearing housing	Bolt	M10	6	33	3.3	24	

MAINTENANCE SPECIFICATIONS

SPEC



Part to be tightened	Part name	Thread size	Q'ty	Tightening torque			Remarks
				Nm	m.kg	ft.lb	
Middle driven gear bearing retainer	Nut	M65	1	110	11	80	Left-hand threads
Yoke (middle driven gear)	Nut	M14	1	97	9.7	70	
Middle driven gear bearing housing	Bolt	M8	4	25	2.5	18	
Yoke (middle driven shaft)	Nut	M14	1	97	9.7	70	
Middle driven shaft bearing retainer	Nut	M55	1	80	8.0	58	Left-hand threads
Shift arm	Bolt	M6	1	14	1.4	10	
Shift rod	Nut	M6	2	8	0.8	5.8	
Primary sheave assembly	Nut	M16	1	100	10.0	72	
Secondary sheave assembly	Nut	M16	1	100	10.0	72	
Secondary sheave spring retainer	Nut	M36	1	90	9.0	65	
Select lever unit bracket	Bolt	M6	3	12	1.2	8.7	
Select lever unit	Bolt	M8	3	15	1.5	11	
Shift cam ball holding bolt	—	M14	1	18	1.8	13	
Neutral switch	—	M10	2	20	2.0	14	
Stator coil	Screw	M6	3	7	0.7	5.1	
Pickup coil	Bolt	M5	2	7	0.7	5.1	
Lead holder	Bolt	M6	2	10	1.0	7.2	
Ignition coil	Bolt	M6	2	7	0.7	5.1	
Thermo unit	—	M12	1	20	2.0	14	



CHASSIS

Item	Standard	Limit
Steering system:		
Steering bearing type	Ball bearing	----
Front suspension:		
Shock absorber travel	151 mm (5.94 in)	----
Fork spring free length	396 mm (15.6 in)	----
Spring rate (K1)	1 N/mm (1 kg/mm, 56.00 lb/in)	----
Optional spring	No	----
Rear suspension:		
Shock absorber travel	122.5 mm (4.82 in)	----
Spring 1 free length	274.9 mm (10.82 in)	----
Spring 2 free length	107.8 mm (4.24 in)	----
Spring 1 fitting length	235.7 mm (9.28 in)	----
Spring 2 fitting length	90.5 mm (3.56 in)	----
Spring rate (K1)	3 N/mm (3 kg/mm, 168.0 lb/in)	----
(K2)	4.39 N/mm (4.39 kg/mm, 245.8 lb/in)	----
Optional spring	No	----
Stroke (soft) (K1)	0 ~ 90 mm (0.00 ~ 3.54 in)	----
(K2)	90.0 ~ 122.5 mm (3.54 ~ 4.82 in)	----
Stroke (hard) (K1)	0 ~ 27 mm (0.00 ~ 1.06 in)	----
(K2)	27.0 ~ 122.5 mm (1.06 ~ 4.82 in)	----
Swingarm:		
Free play limit end	----	1 mm (0.04 in)
side	----	1 mm (0.04 in)
Front wheel:		
Type	Disc wheel	----
Rim size	12 × 6.5AT	----
Rim material	Steel	----
Rim runout limit radial	----	2 mm (0.08 in)
lateral	----	2 mm (0.08 in)
Rear wheel:		
Type	Disc wheel	----
Rim size	10 × 8.0AT	----
Rim material	Steel	----
Rim runout limit radial	----	2 mm (0.08 in)
lateral	----	2 mm (0.08 in)

MAINTENANCE SPECIFICATIONS











SPEC



Item	Standard	Limit
Front disc brake:		
Type	Dual	----
Disc outside diameter × thickness	220.0 × 3.5 mm (8.66 ~ 0.14 in)	----
Pad thickness inner	4.2 mm (0.17 in)	1 mm (0.04 in)
Pad thickness outer	4.2 mm (0.17 in)	1 mm (0.04 in)
Master cylinder inside diameter	15.87 mm (0.62 in)	----
Caliper cylinder inside diameter	32.03 mm (1.26 in)	----
Brake fluid type	DOT 4	----
Rear drum brake:		
Type	Leading, trailing	----
Brake drum inside diameter	160 mm (6.30 in)	161 mm (6.34 in)
Lining thickness	4 mm (0.16 in)	1 mm (0.04 in)
Shoe spring free length	68 mm (2.7 in)	----
Brake lever and brake pedal:		
Brake lever free play (at lever end)	2 ~ 5 mm (0.08 ~ 0.20 in)	----
Brake lever free play (left)	5 ~ 7 mm (0.20 ~ 0.28 in)	----
Brake pedal position	20 ~ 30 mm (0.8 ~ 1.2 in)	----
Brake pedal free play	20 ~ 30 mm (0.8 ~ 1.2 in)	----
Throttle lever free play	3 ~ 5 mm (0.12 ~ 0.20 in)	----





Tightening torques

Part to be tightened	Thread size	Tightening torque			Remarks
		Nm	m·kg	ft·lb	
Engine bracket (front-upper) and frame	M8	33	3.3	24	
Engine bracket (front-middle) and frame	M8	33	3.3	24	
Engine bracket (front-upper) and engine	M10	42	4.2	30	
Engine bracket (front-middle) and engine	M10	42	4.2	30	
Engine and frame	M10	56	5.6	40	
Frame and bearing retainer (steering stem holder bearing)	M42	40	4.0	29	
Pivot shaft (right) and frame	M22	130	13.0	94	
Pivot shaft (left) and frame	M22	6	0.6	4.3	
Pivot shaft (left) and nut	M22	130	13.0	94	
Rear shock absorber and frame	M12	59	5.9	43	
Final gear case and swingarm	M10	57	5.7	41	
Final gear case bearing housing and swingarm	M10	65	6.5	47	
Final gear case and rear axle housing	M10	65	6.5	47	
Swingarm and rear axle housing	M12	90	9.5	65	
Differential gear case and frame	M10	55	5.5	40	
Front arm and frame	M10	45	4.5	32	
Front shock absorber and frame	M35	55	5.5	40	
Front shock absorber and steering knuckle	M12	115	11.5	85	
Steering stem, pitman arm and frame	M12	84	8.4	61	
Steering stem holder and frame	M8	23	2.3	17	Use lock washer
Steering stem and handlebar holder	M8	20	2.0	14	
Pitman arm and tie-rod end	M10	25	2.5	18	
Tie-rod and locknut	M10	15	1.5	11	
Steering knuckle and front arm	M10	48	4.8	35	
Steering knuckle and tie-rod	M10	25	2.5	18	
Fuel tank and fuel cock	M6	4	0.4	2.9	
Front wheel and wheel hub	M10	64	6.4	46	
Front axle and wheel hub	M16	150	15.0	110	
Steering knuckle and brake caliper	M8	30	3.0	22	
Front brake disc and wheel hub	M8	30	3.0	22	
Rear wheel and rear wheel hub	M10	55	5.5	40	
Rear wheel and brake drum	M10	55	5.5	40	
Rear axle and nut	M16	150	15	110	
Rear brake camshaft and camshaft lever	M6	9	0.9	6.5	
Swingarm and rear brake plate	M8	28	2.8	20	
Front brake pipe nut	M10	19	1.9	13	
Front brake hose union bolt	M10	27	2.7	19	
Bleed screw	M8	6	0.6	4.3	
Master cylinder and handlebar	M6	7	0.7	5.1	
Footrest and frame	M10	55	5.5	40	

MAINTENANCE SPECIFICATIONS

SPEC



Part to be tightened	Thread size	Tightening torque			Remarks
		Nm	m·kg	ft·lb	
Front bumper and frame	M8	31	3.1	22	
Rear carrier bar and frame	M8	35	3.5	25	
Rear carrier and frame	M8	35	3.5	25	
Differential gear case filler bolt	M14	23	2.3	17	
Differential gear case drain bolt	M10	19	1.9	13	
Universal joint yoke (differential gear)	M14	62	6.2	45	
Ring gear	M8	39	3.9	28	
Differential gear case and bearing housing	M8	25	2.5	18	
Bearing housing (drive pinion gear) and differential gear case	M8	18	1.8	13	
Gear motor	M8	13	1.3	9.4	
4WD switch	M10	19	1.9	13	
Final gear case oil filler bolt	M14	23	2.3	17	
Final gear case oil drain bolt	M14	23	2.3	17	
Bearing retainer (drive pinion gear)	M65	100	10.0	72	
Final gear case and bearing housing	M10	40	4.0	29	
Final gear case and bearing housing	M8	23	2.3	17	



ELECTRICAL

Item	Standard	Limit
Voltage:	12 V	----
Ignition system:		
Ignition timing (B.T.D.C.)	12° / 1,000 r/min	----
Advanced timing (B.T.D.C.)	28° / 4,000 r/min	----
Advancer type	Electrical type	----
<p>The graph plots Ignition timing (B.T.D.C.) on the y-axis (0 to 30 degrees) against Engine speed (x10³r/min) on the x-axis (0 to 10). The timing is constant at 12° for engine speeds up to 2.0 x 10³ r/min. It then increases to 22° at 3.5 x 10³ r/min and remains constant at 22° until 4.0 x 10³ r/min. Finally, it increases to 28° at 4.0 x 10³ r/min and remains constant at 28° for higher engine speeds.</p>		
C.D.I.:		
Magneto model / manufacturer	F4T42571/MITSUBISHI	----
Pickup coil resistance / color	459 ~ 561 Ω at 20°C (68°F) / Red – White	----
Source coil resistance / color	270 ~ 330 Ω at 20°C (68°F) / Brown – Green	----
C.D.I. unit model / manufacturer	F8T34671/MITSUBISHI	----
Ignition coil:		
Model / manufacturer	2JN/YAMAHA	----
Minimum spark gap	6 mm (0.24 in)	----
Primary winding resistance	0.18 ~ 0.28 Ω at 20°C (68°F)	----
Secondary winding resistance	6.32 ~ 9.48 kΩ at 20°C (68°F)	----
Spark plug cap:		
Type	Resin type	----
Resistance	10 kΩ	----
Charging system:		
Type	A.C. magneto generator	----
Model / manufacturer	F8T34671/MITSUBISHI	----
Nominal output	14 V 12 A at 3,000 r/min	----
Stator coil resistance / color	0.702 ~ 0.858 Ω at 20°C (68°F) / White – White	----
Rectifier:		
Model / manufacturer	SH640-12/SHINDENGEN	----
Capacity	14 A	----
Withstand voltage	200 V	----

MAINTENANCE SPECIFICATIONS

SPEC



Item	Standard	Limit
Electric starter system:		
Type	Bendix type	----
Starter motor:		
Model / manufacturer	SM-13/MITSUBA	----
I.D. number	SM-13486	----
Output	0.7 kW	----
Armature coil resistance	0.0249 ~ 0.0351 Ω at 20°C (68°F)	----
Brush overall length	6 mm (0.24 in)	5 mm (0.20 in)
Spring force	780 ~ 1.021 g (27.5 ~ 36.0 oz)	----
Commutator diameter	28 mm (1.10 in)	27 mm (1.06 in)
Mica undercut	0.7 mm (0.028 in)	----
Starter relay:		
Model / manufacturer	MS5E-491/JIDECO	----
Amperage rating	100 A	----
Coil winding resistance	4.18 ~ 4.62 Ω at 20°C (68°F)	----
Circuit breaker:		
Type	Fuse	----
Amperage for individual circuit:		
Main fuse	30 A × 1	----
Tarminal fuse	10 A × 1	----
Reserve	30 A × 1	----
Reserve	10 A × 1	----

HOW TO USE THE CONVERSION TABLE/ GENERAL TORQUE SPECIFICATIONS



EB201000

HOW TO USE THE CONVERSION TABLE

All specification data in this manual are listed in SI and METRIC UNITS.

Use this table to convert METRIC unit data to IMPERIAL unit data.

Ex.

METRIC		MULTIPLIER	=	IMPERIAL
** mm	×	0.03937	=	** in
2 mm	×	0.03937	=	0.08 in

CONVERSION TABLE

METRIC TO IMPERIAL			
	Metric unit	Multiplier	Imperial unit
Torque	m·kg	7.233	ft·lb
	m·kg	86.794	in·lb
	cm·kg	0.0723	ft·lb
	cm·kg	0.8679	in·lb
Weight	kg	2.205	lb
	g	0.03527	oz
Speed	km/hr	0.6214	mph
Distance	km	0.6214	mi
	m	3.281	ft
	m	1.094	yd
	cm	0.3937	in
	mm	0.03937	in
Volume/ Capacity	cc (cm ³)	0.03527	oz (IMP liq.)
	cc (cm ³)	0.06102	cu-in
	lt (liter)	0.8799	qt (IMP liq.)
	lt (liter)	0.2199	gal (IMP liq.)
Misc.	kg/mm	55.997	lb/in
	kg/cm ²	14.2234	psi (lb/in ²)
	Centigrade (°C)	9/5+32	Fahrenheit (°F)

EB202001

GENERAL TORQUE SPECIFICATIONS

This chart specifies torque for standard fasteners with standard I.S.O. pitch threads. Torque specifications for special components or assemblies are provided for each chapter of this manual. To avoid warpage, tighten multi-fastener assemblies in a criss-cross fashion, in progressive stages, until the specified torque is reached. Unless otherwise specified, torque specifications require clean, dry threads. Components should be at room temperature.

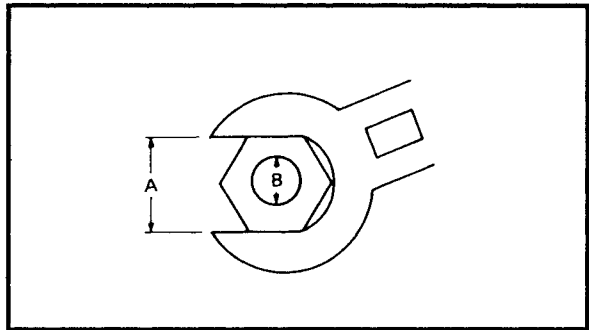

A: Distance between flats
B: Outside thread diameter

A (nut)	B (bolt)	General torque specifications		
		Nm	m·kg	ft·lb
10 mm	6 mm	6	0.6	4.3
12 mm	8 mm	15	1.5	11
14 mm	10 mm	30	3.0	22
17 mm	12 mm	55	5.5	40
19 mm	14 mm	85	8.5	61
22 mm	16 mm	130	13.0	94



LUBRICATION POINTS AND LUBRICANT TYPES

ENGINE

Lubrication points	Lubricant type
Oil seal lips (all)	
O-ring (all)	
Bearings (all)	
Crank pin	
Connecting rod (bearing)	
Camshaft sprocket	
Balancer driven gear	
Piston surface/piston rings	
Piston pin	
Buffer boss	
Valve stem/valve stem end	
Rocker arm shaft	
Rocker arm	
Camshaft lobe/journal	
Oil pump shaft, rotor, housing	
Starter idle gear 1,2	
Starter wheel gear	
Transmission gear (wheel/pinion)	
Axle (main/drive)	
Shift fork/guide bar	
Shift cam/shift shaft	
Shift lever (select lever)	
Speedometer gear unit	
Clutch housing	
Gear coupling	
Driven cam	
Crankcase mating surfaces	Sealant (Quick Gasket®) Yamaha Bond No.1215
Middle drive axle cover	Sealant (Quick Gasket®) Yamaha Bond No.1215
Starter lead grommet (left side crankcase)	Sealant (Quick Gasket®) Yamaha Bond No.1215



LUBRICATION DIAGRAMS

- ① Crankshaft
- ② Oil filter
- ③ Oil pump
- ④ Relief valve
- ⑤ Oil strainer
- ⑥ Oil delivery pipe

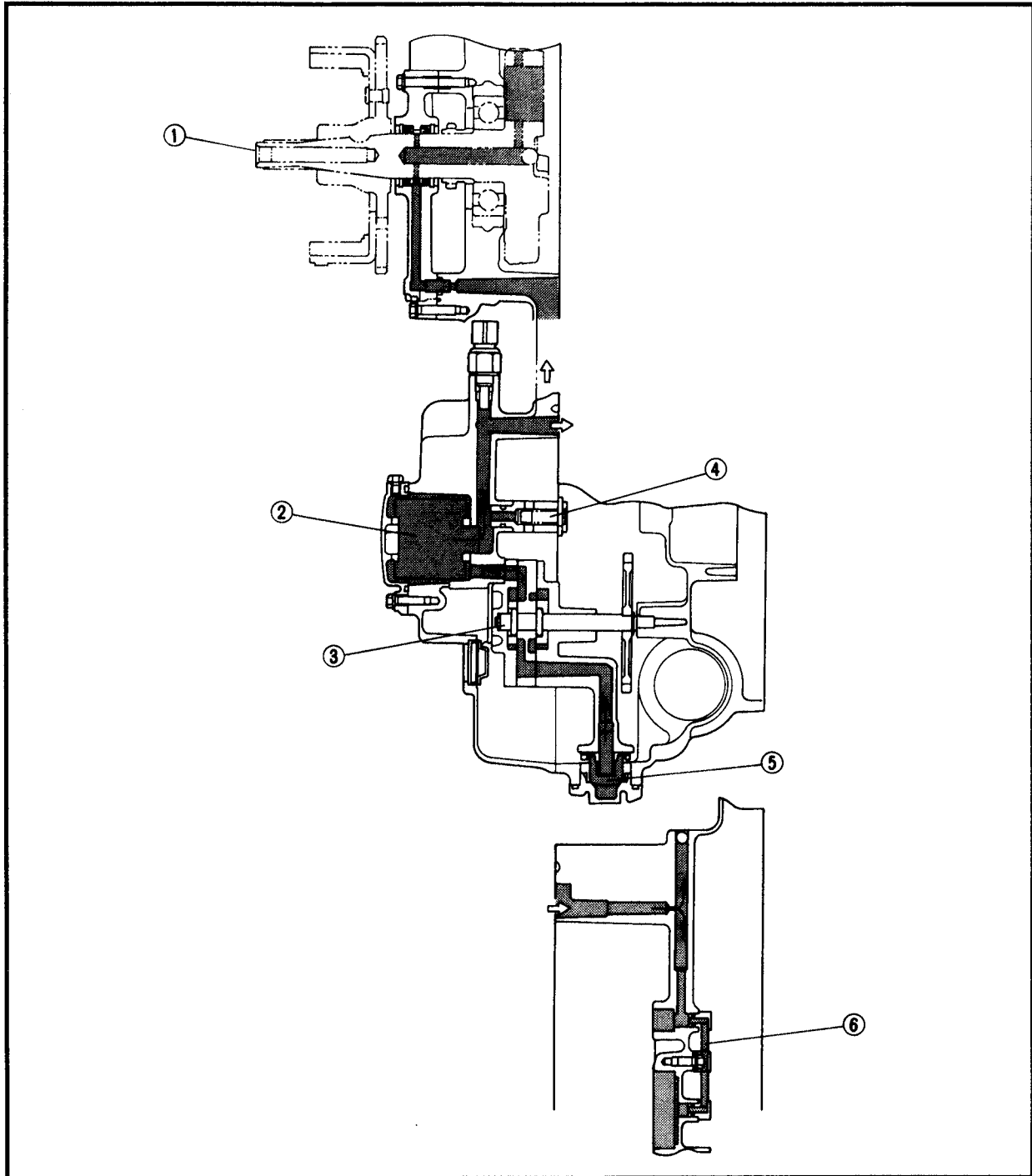



- ① Relief valve
- ② Oil strainer
- ③ Oil pump
- ④ Oil delivery pipe

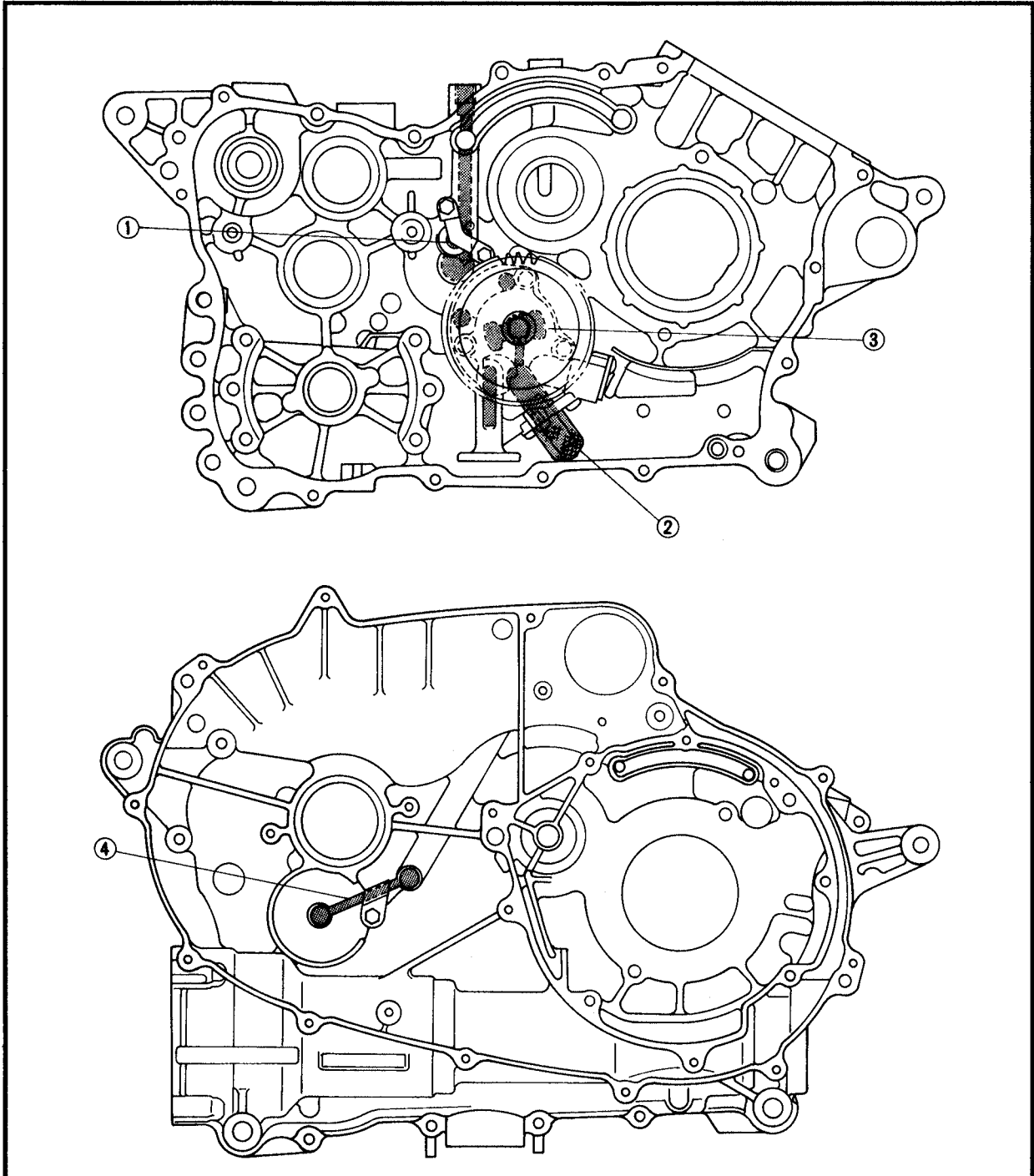



- ① Oil cooler
- ② Oil cooler hose

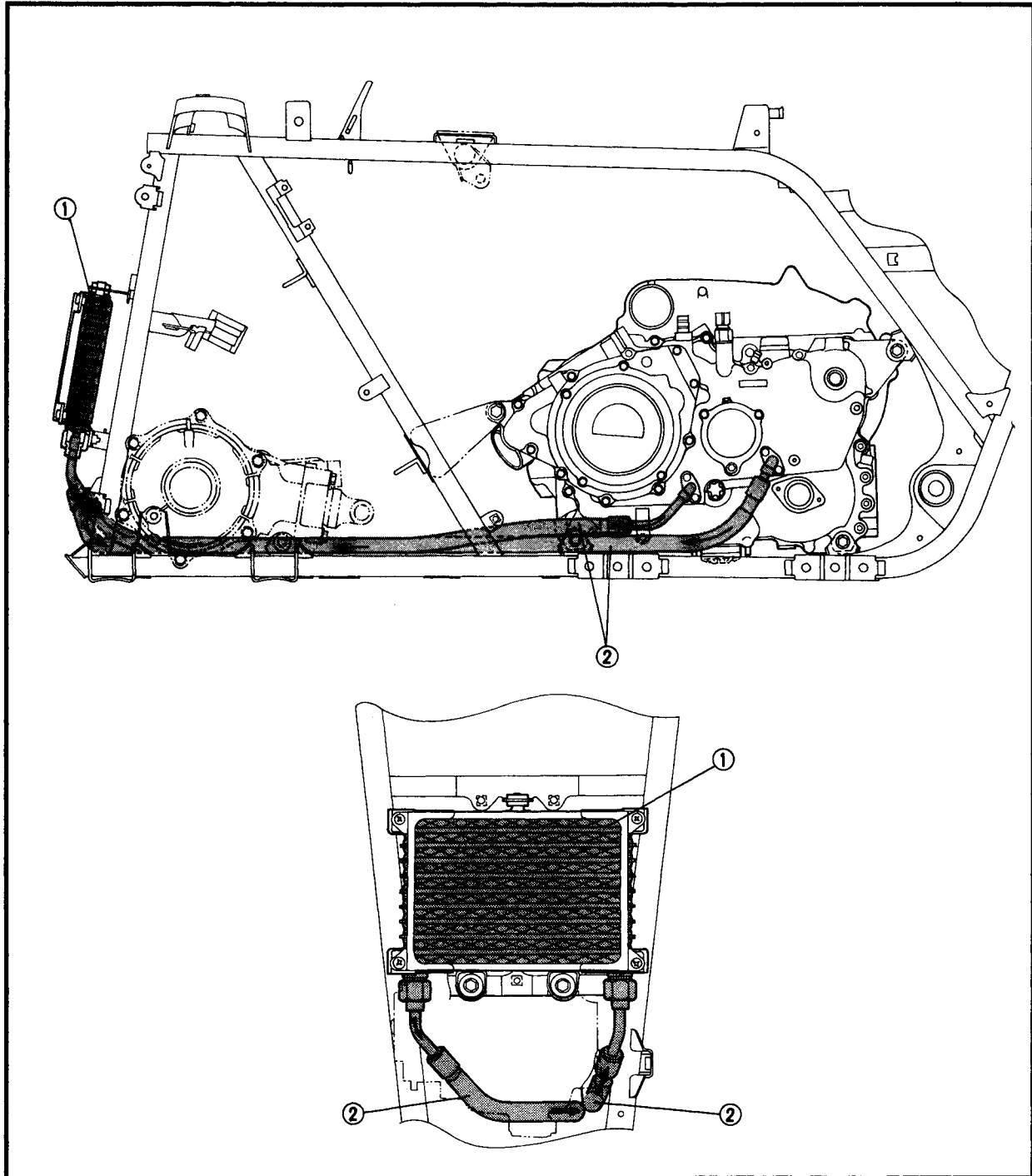



CABLE ROUTING

- ① Rear brake switch
- ② Rear brake cable
- ③ Terminal
- ④ Front brake hose
- ⑤ 2WD/4WD select switch
- ⑥ Fuel tank breather hose
- ⑦ 2WD/4WD select switch lead
- ⑧ Throttle cable
- ⑨ Handlebar switch lead
- ⑩ Rear brake switch lead
- ⑪ Indicator light lead
- ⑫ Main switch lead
- ⑬ Speedometer lead
- ⑭ Brake pipe
- ⑮ Fan motor

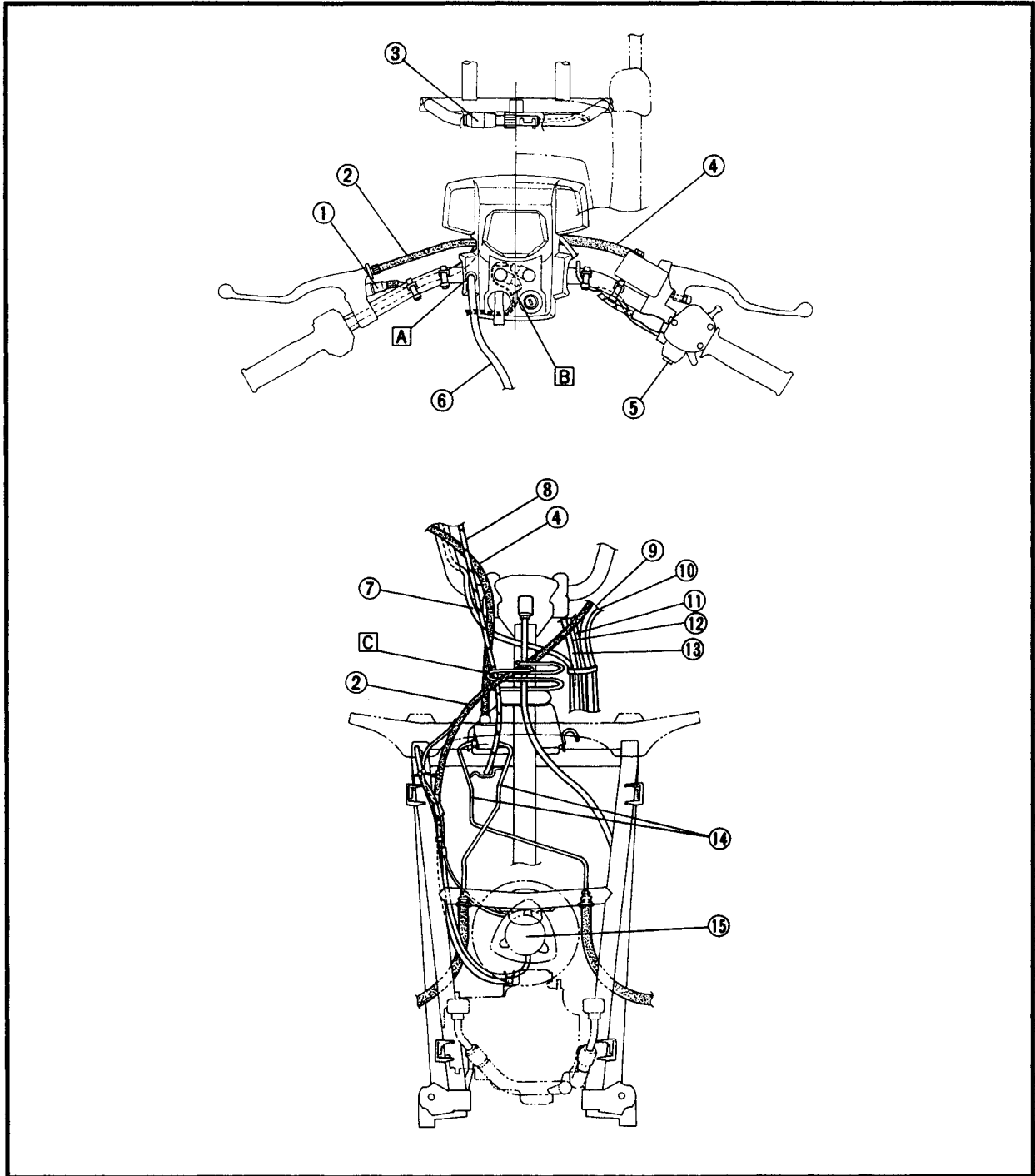



- A Insert the breather hose (fuel tank) into the hole in the handlebar cover.
- B Pass the indicator light leads between the starter knob and main switch, then connect the leads on the inside of the handlebar cover.
- C Pass the rear brake cable through the front part of the cable guide and pass the speedometer cable and throttle cable through the rear part of the cable guide.

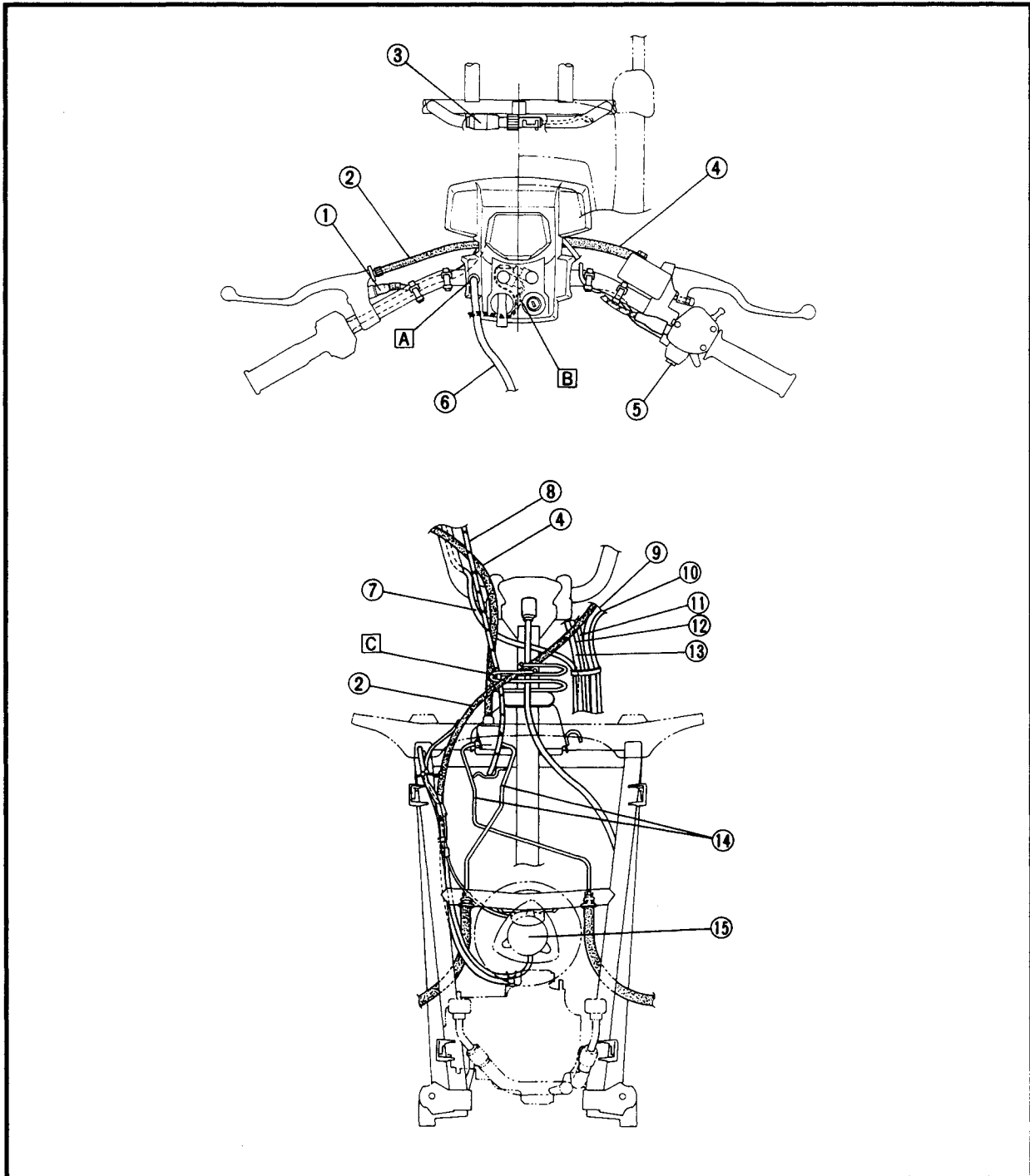

- ① Headlight lead
- ② Fuel tank breather hose
- ③ Rectifier/regulator
- ④ CDI unit
- ⑤ Carburetor overflow hose
- ⑥ Carburetor drain hose
- ⑦ Ignition coil
- ⑧ Fan motor control unit
- ⑨ Fan motor relay
- ⑩ Starting circuit cut-off relay
- ⑪ Reverse relay
- ⑫ Starter relay
- ⑬ Select lever control cable
- ⑭ Starter cable
- ⑮ Carburetor breather hose
- ⑯ Rear brake breather hose
- ⑰ Final drive gear breather hose
- ⑱ Rear shock absorber breather hose
- ⑲ Battery negative lead (ground lead)
- ⑳ Starter motor lead

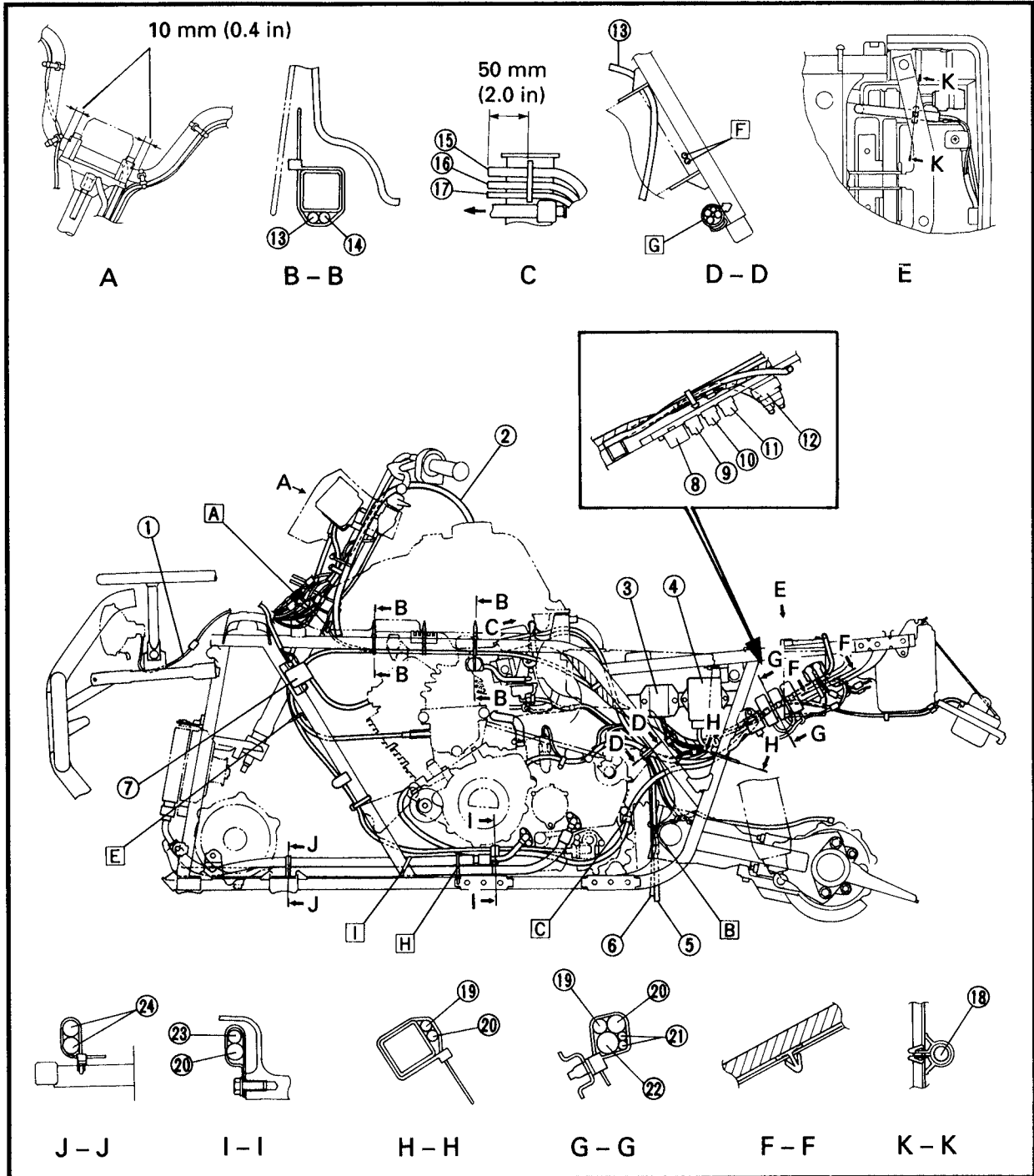

CABLE ROUTING

SPEC



- ① Taillight lead
- ② Wire harness
- ③ Speedometer cable
- ④ Oil cooler hose

- A Pass the starter cable through the wire guide.
- B Pass the carburetor overflow hose and carburetor drain hose through the metal guide on the swingarm.
- C Fasten the starter motor lead with a metal clamp.
- D Fasten the CDI magneto lead and thermo unit lead with a metal clamp.

- E Pass the speedometer cable through the metal guide.
- F Pass the carburetor overflow hose and the carburetor drain hose toward the left side of the vehicle and between the engine and the frame.
- G Fasten the battery negative lead (ground lead), neutral switch/reverse switch lead, starter motor lead, thermo unit lead and rear brake breather hose with plastic clamp.
- H Fasten the oil cooler hoses with the plastic locking tie. The plastic locking tie should not be overtightened.
- I Fasten the oil cooler hoses to the frame with the plastic locking tie.

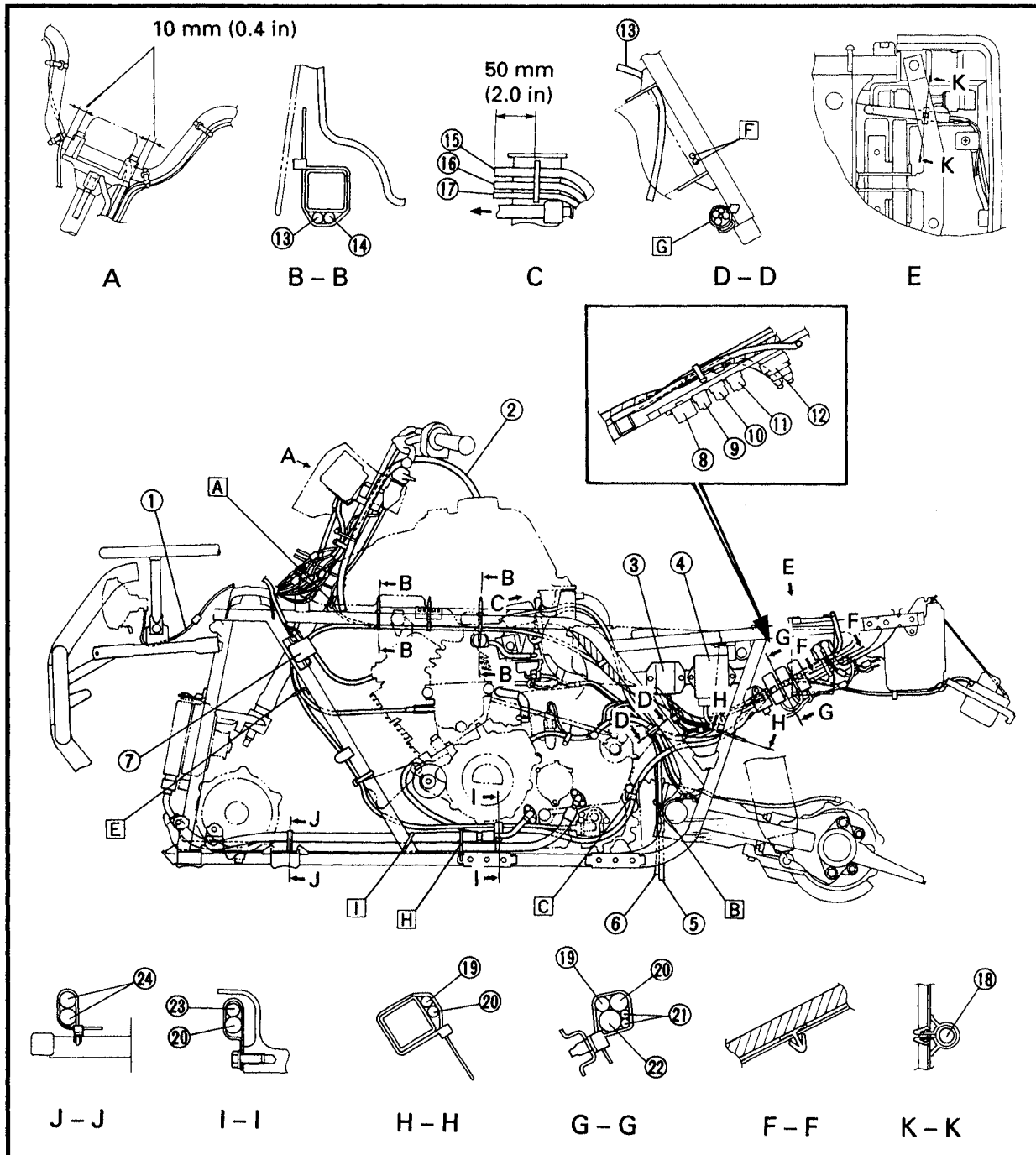



- ① Select lever control cable
- ② Gear motor
- ③ 4WD switch
- ④ Rear brake cable (brake lever)
- ⑤ Rear brake cable (brake pedal)
- ⑥ Fan motor breather hose
- ⑦ Differential gear breather hose
- ⑧ Gear motor lead

- [A] Pass the throttle cable through the metal guide.
- [B] Pass the differential gear breather hose and fan motor breather hose through the hole in the right side frame.
- [C] Fasten the fan motor breather hose and differential gear breather hose with a plastic clip.
- [D] Pass the rear brake cable (brake lever) through the metal guide.

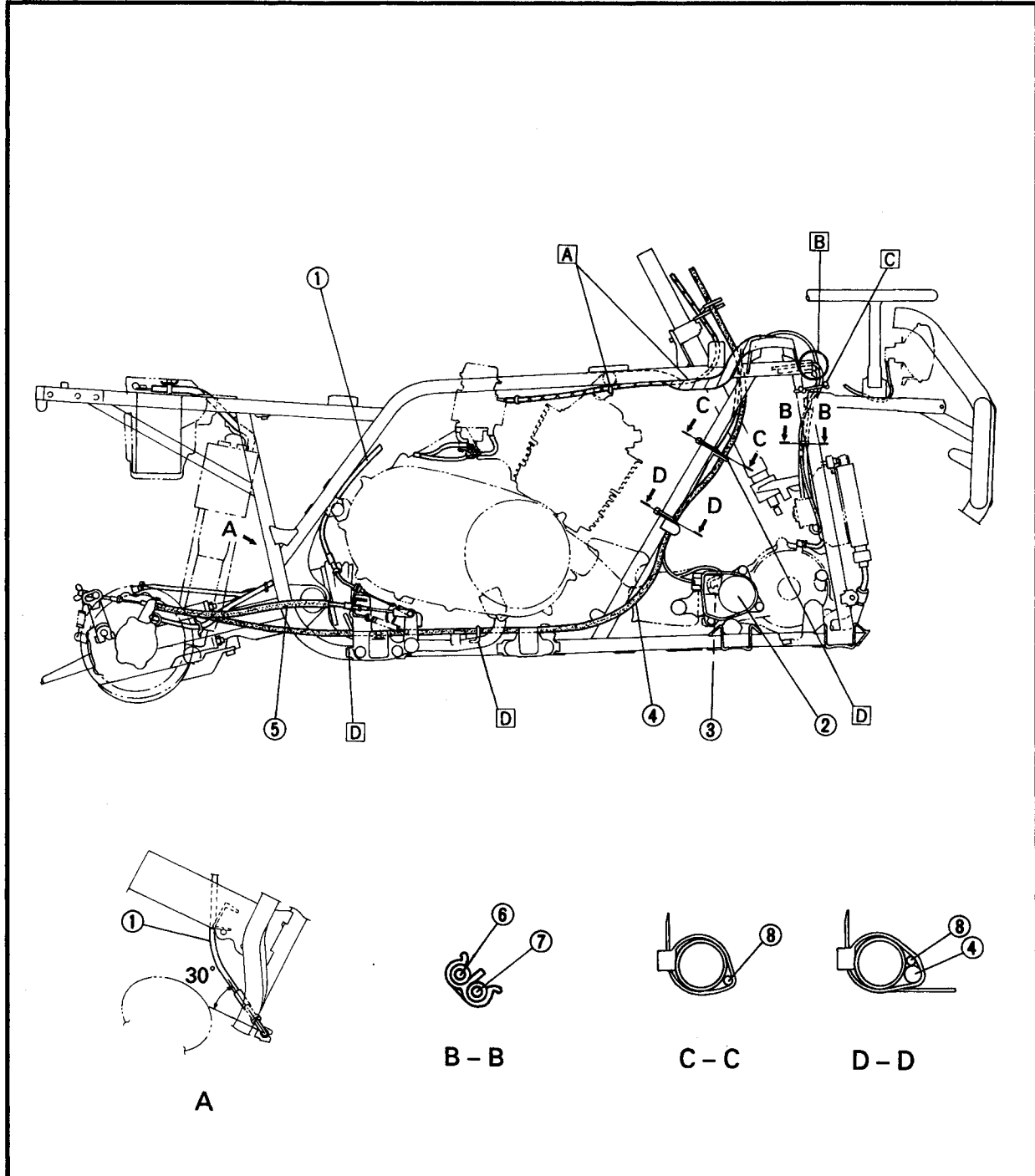



- ① Headlight lead
- ② Diode
- ③ Wire harness
- ④ Throttle cable
- ⑤ Select lever control cable
- ⑥ Main fuse
- ⑦ Terminal fuse
- ⑧ Battery
- ⑨ Starter cable
- ⑩ Taillight lead
- ⑪ Rear brake breather hose
- ⑫ Final drive gear breather hose
- ⑬ Fuse lead

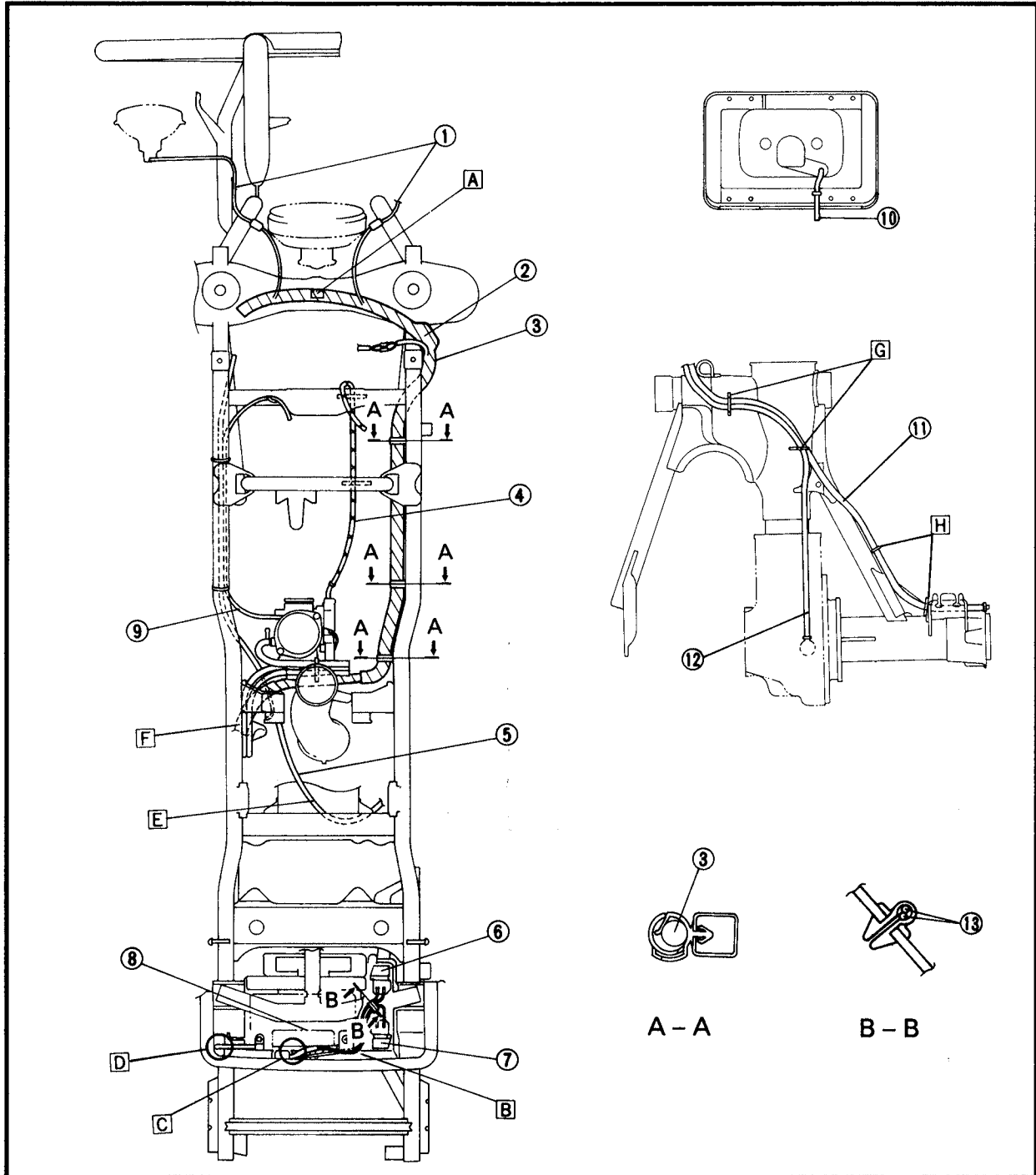

CABLE ROUTING

SPEC



- A Insert the wire harness T-joint into the hole in the frame.
- B Pass the fuse lead under the battery positive lead.
- C Pass the battery positive lead and the fuse lead through the hole in the rear fender.
- D Pass the battery negative lead through the hole in the rear fender.
- E Pass the select lever control cable between the engine and the frame.

- F Pass the final drive gear breather hose and the rear brake breather hose over the air filter case mounting bracket on the frame.
- G Pass the rear brake breather hose and the final drive gear breather hose through the metal guides on the swingarm.
- H Pass the rear brake breather hose through the metal guides on the swingarm.

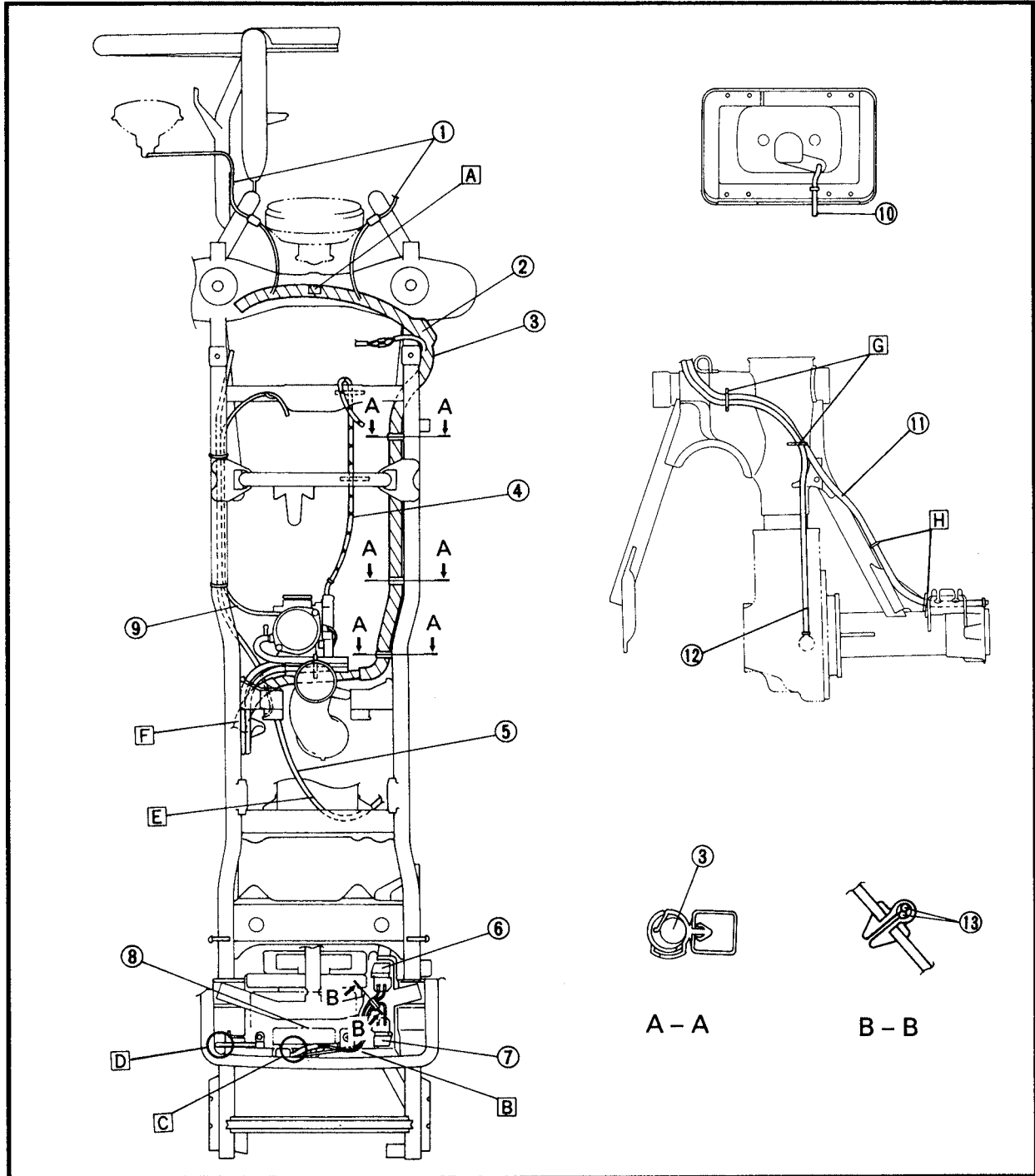

EB300000

PERIODIC INSPECTIONS AND ADJUSTMENTS

INTRODUCTION

This chapter includes all information necessary to perform recommended inspections and adjustments. These preventive maintenance procedures, if followed, will ensure more reliable vehicle operation and a longer service life. The need for costly overhaul work will be greatly reduced. This information applies to vehicles already in service as well as to new vehicles that are being prepared for sale. All service technicians should be familiar with this entire chapter.

EB301000

PERIODIC MAINTENANCE/LUBRICATION INTERVALS

ITEM	ROUTINE	INITIAL			EVERY	
		1 month	3 months	6 months	6 months	1 year
Valves*	<ul style="list-style-type: none"> • Check valve clearance. • Adjust if necessary. 	○		○	○	○
Spark plug	<ul style="list-style-type: none"> • Check condition. • Adjust gap and clean. • Replace if necessary. 	○	○	○	○	○
Air filter	<ul style="list-style-type: none"> • Clean. • Replace if necessary. 	Every 20-40 hours (More often in wet or dusty areas.)				
Carburetor*	<ul style="list-style-type: none"> • Check and adjust idle speed/starter operation. • Adjust if necessary. 		○	○	○	○
Crankcase breather system*	<ul style="list-style-type: none"> • Check breather hose for cracks or damage. • Replace if necessary. 			○	○	○
Exhaust system*	<ul style="list-style-type: none"> • Check for leakage. • Retighten if necessary. • Replace gasket(s) if necessary. 			○	○	○
Fuel line*	<ul style="list-style-type: none"> • Check fuel hose for cracks or damage. • Replace if necessary. 			○	○	○
Engine oil	<ul style="list-style-type: none"> • Replace (Warm engine before draining). 	○		○	○	○
Engine oil filter	<ul style="list-style-type: none"> • Replace. 	○		○		○
Engine oil strainer	<ul style="list-style-type: none"> • Clean. 	○		○		○
Final gear oil	<ul style="list-style-type: none"> • Check oil level/oil leakage. 	○				○
Differential gear oil	<ul style="list-style-type: none"> • Replace every 12 months. 	○				○
Front brake*	<ul style="list-style-type: none"> • Check operation/fluid leakage/see NOTE. • Correct if necessary. 	○	○	○	○	○
Rear brake*	<ul style="list-style-type: none"> • Check operation. • Adjust if necessary. • Check dust seal for cracks or damage. 	○	○	○	○	○
V-belt*	<ul style="list-style-type: none"> • Check operation. • Check for cracks or damage every 12 months or 2,400 km (1,500 mi) whichever comes first. 	○				○
Reverse lock release wire*	<ul style="list-style-type: none"> • Check operation. • Adjust if necessary. 			○	○	○
Wheels*	<ul style="list-style-type: none"> • Check balance/damage/runout. • Repair if necessary. 	○		○	○	○
Wheel bearing*	<ul style="list-style-type: none"> • Check bearing assemblies for looseness/damage. • Replace if damaged. 	○		○	○	○
Front and rear suspension*	<ul style="list-style-type: none"> • Check operation. • Correct if necessary. 			○		○
Steering system*	<ul style="list-style-type: none"> • Check operation/Replace if damaged. • Check toe-in/Adjust if necessary. 	○	○	○	○	○
Front axle boots*	<ul style="list-style-type: none"> • Check operation. • Replace if damaged. 	○				○

3

PERIODIC MAINTENANCE/LUBRICATION INTERVALS



ITEM	ROUTINE	INITIAL			EVERY	
		1 month	3 months	6 months	6 months	1 year
Fittings/Fasteners*	<ul style="list-style-type: none"> • Check all chassis fittings and fasteners. • Correct if necessary. 	○	○	○	○	○

* It is recommended that these items be serviced by a Yamaha dealer.

NOTE: _____

- Recommended brake fluid: DOT 4
(If DOT 4 is not available, DOT 3 can be used.)
- Brake fluid replacement:
 1. When disassembling the master cylinder or caliper cylinder, replace the brake fluid. Normally check the brake fluid level and add fluid as required.
 2. On the inner parts of the master cylinder and caliper cylinder, replace the oil seals every two years.
 3. Replace the brake hoses every four years, or if cracked or damaged.

⚠ WARNING _____

Indicates a potential hazard that could result in serious injury or death.

SEAT, CARRIERS, FENDERS AND FUEL TANK
SEAT

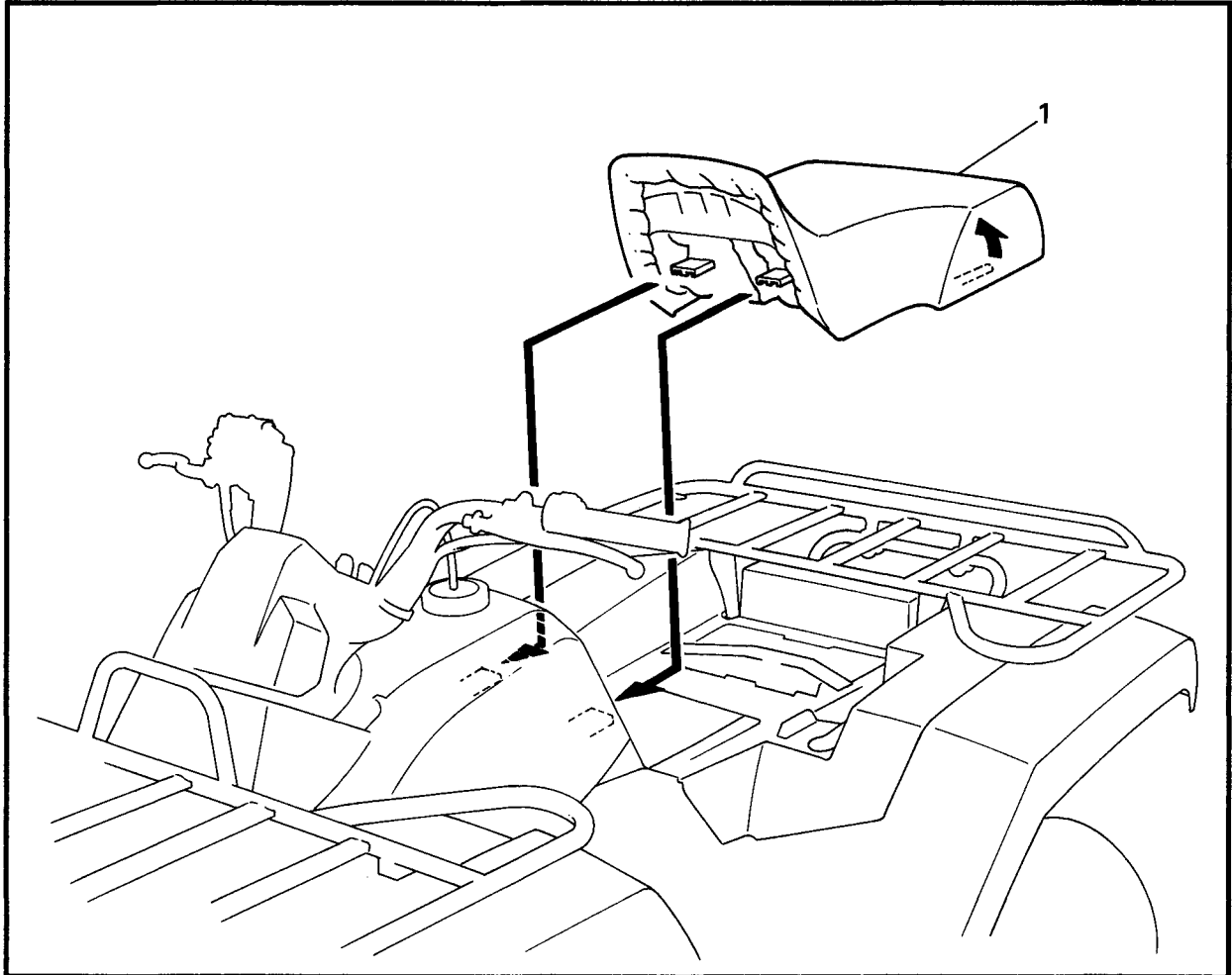

Order	Job name/Part name	Q'ty	Remarks
1	Seat removal Seat	1	Remove the parts in the order below. NOTE: _____ Pull up the seat lock lever, then pull up on the rear of the seat. _____ For installation, reverse the removal procedure.

FRONT CARRIER, FRONT BUMPER AND FRONT FENDER

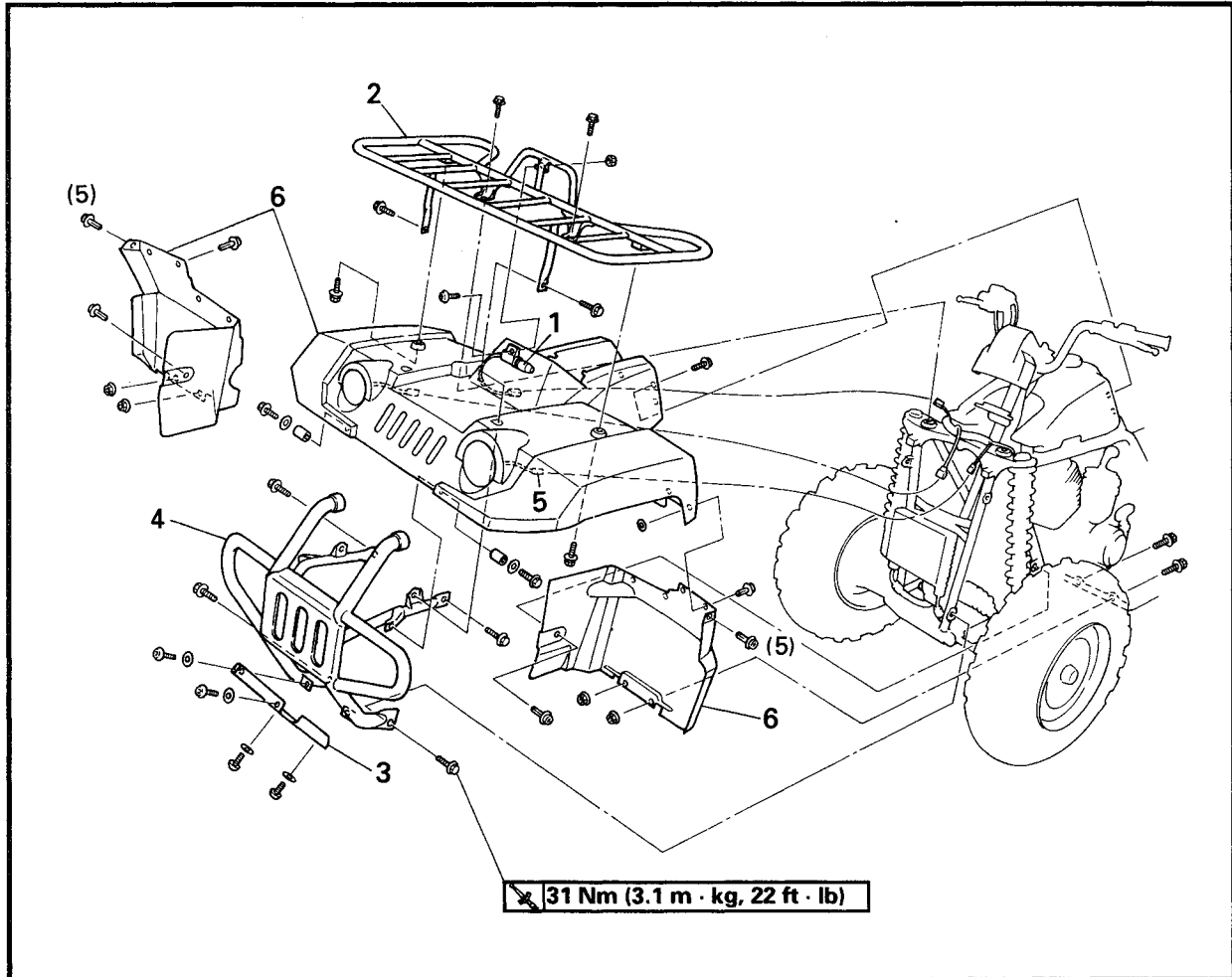

Order	Job name/Part name	Q'ty	Remarks
	Front carrier, front bumper and front fender removal		Remove the parts in the order below.
	Seat		Refer to "SEAT".
1	Terminal	1	
2	Front carrier	1	
3	Differential gear skid plate	1	
4	Front bumper	1	
5	Headlight lead	2	Disconnect
6	Front fender	1	
			For installation, reverse the removal procedure.

REAR CARRIER AND REAR FENDER

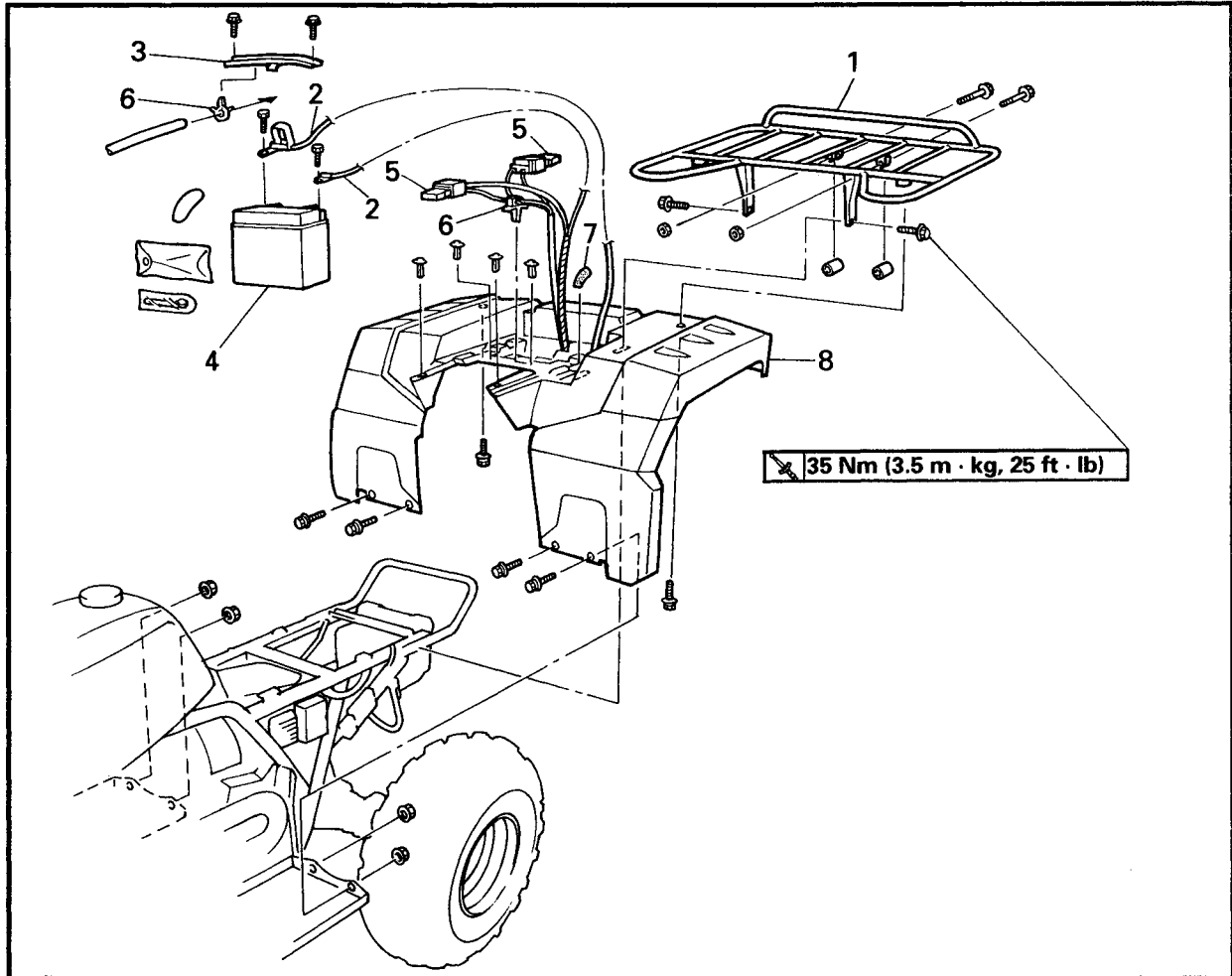

Order	Job name/Part name	Q'ty	Remarks
	Rear carrier and rear fender removal		
	Seat		Remove the parts in the order below. Refer to "SEAT".
1	Rear carrier	1	
2	Battery lead	2	Disconnect
			CAUTION: First disconnect the negative lead, than disconnect the positive lead.
3	Battery holding bracket	1	
4	Battery	1	
5	Fuse	2	
6	Plastic clamp	2	
7	Lever grip	1	
8	Rear fender	1	
			For installation, reverse the removal procedure.

FUEL TANK

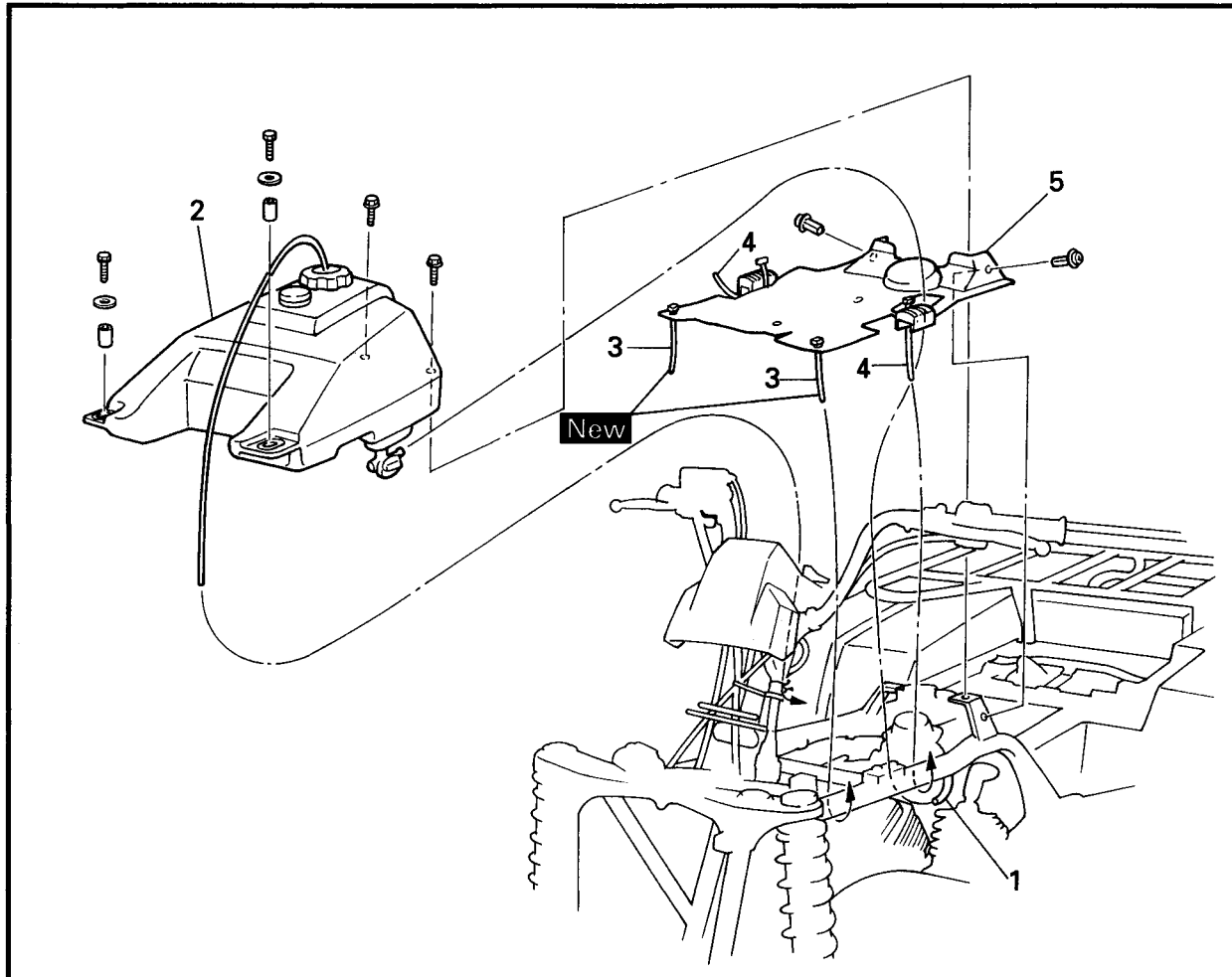

Order	Job name/Part name	Q'ty	Remarks
	Fuel tank removal		
	Seat		Remove the parts in the order below. Refer to "SEAT".
	Front fender		Refer to "FRONT CARRIER, FRONT BUMPER AND FRONT FENDER".
1	Fuel hose	1	NOTE: _____ Before disconnecting the fuel hose, turn the fuel cock to "OFF".
2	Fuel tank	1	NOTE: _____ When installing the fuel tank, pass the fuel tank breather hose through the hole in the handlebar protector.
3	Plastic locking tie	2	
4	Plastic band	2	
5	Rubber cover	1	
			For installation, reverse the removal procedure.

ENGINE VALVE CLEARANCE ADJUSTMENT

NOTE:

- The valve clearance must be adjusted when the engine is cool to the touch.
- Adjust the valve clearance when the piston is at the Top Dead Center (T.D.C.) on the compression stroke.

1.Remove:

- Seat
- Front carrier
- Front fender
- Fuel tank

Refer to "SEAT, CARRIERS, FENDERS AND FUEL TANK".

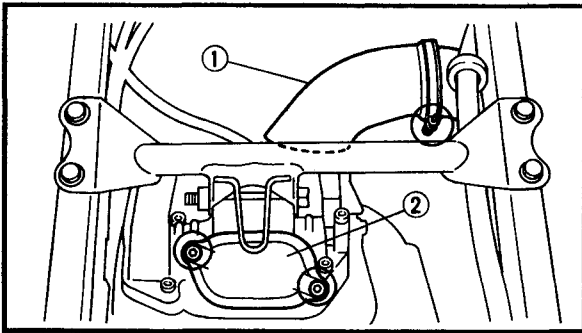

2.Remove:

- Air duct ①
- Tappet cover (intake) ②
- Tappet covers (exhaust) ③

3.Disconnect:

- Spark plug cap ④

4.Remove:

- Spark plug

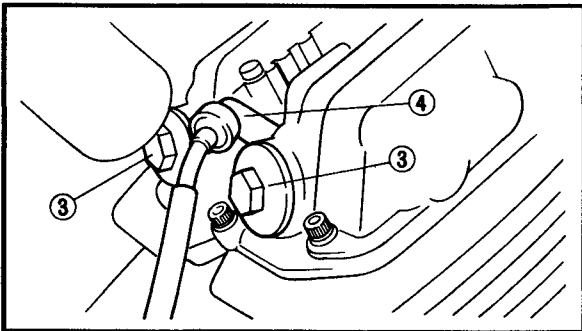

5.Remove:

- Recoil starter ①

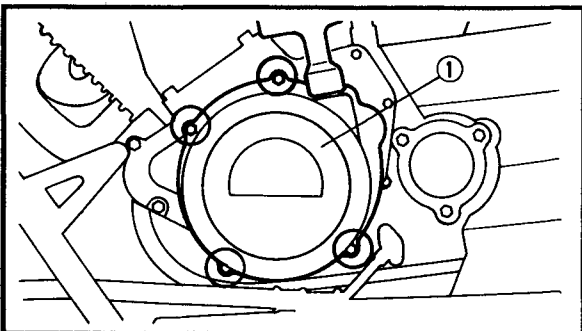

VALVE CLEARANCE ADJUSTMENT

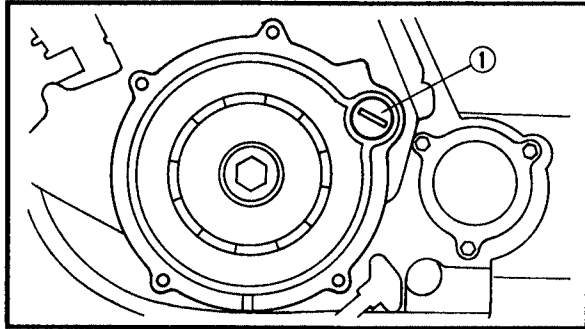

- 6.Remove:
- Timing plug ①

- 7.Check:
- Valve clearance
Out of specification → Adjust.

	Valve clearance (cold): Intake: 0.05 ~ 0.10 mm (0.002 ~ 0.004 in) Exhaust: 0.12 ~ 0.17 mm (0.005 ~ 0.007 in)
--	---

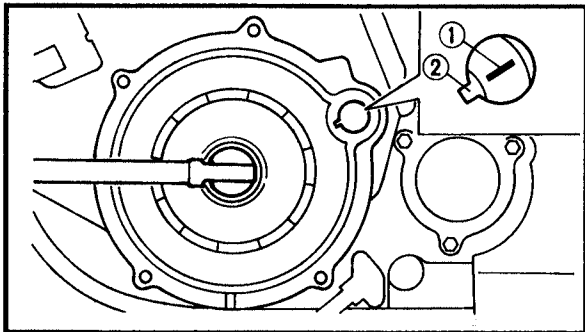

Checking steps:

- Turn the crankshaft counterclockwise with a wrench.
- Align the "I" mark ① on the rotor with the stationary pointer ② on the crankcase cover. When the "I" mark is aligned with the stationary pointer, the piston is at Top Dead Center (T.D.C.).

NOTE:

- When the piston is at top dead center (TDC) on the compression stroke, there should be clearance between the valve stem tips and their respective rocker arm adjusting screws.
- If there is no clearance, rotate the crankshaft counterclockwise one turn.

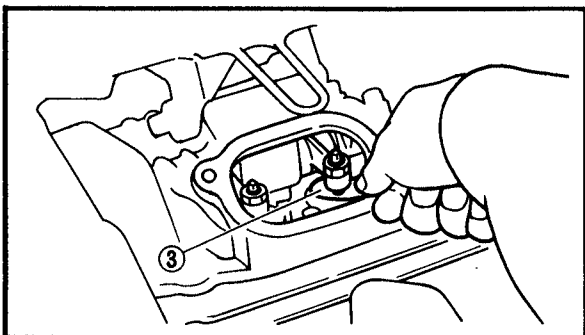

- Measure the valve clearance using a feeler gauge ③.

VALVE CLEARANCE ADJUSTMENT

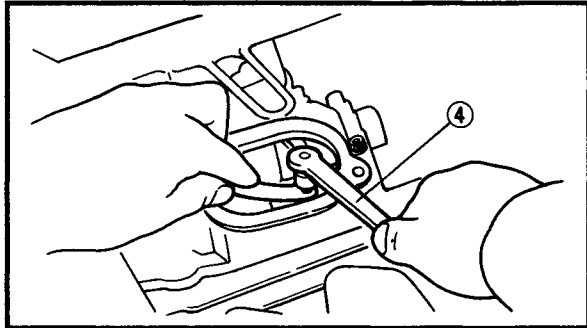
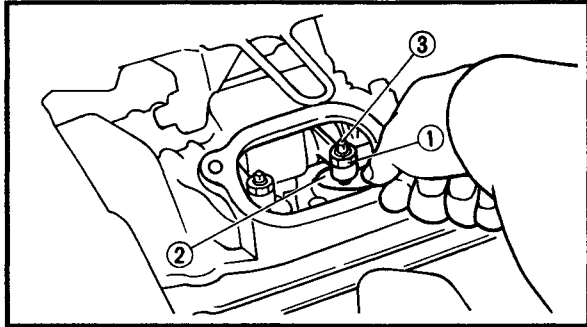

8.Adjust:

- Valve clearance

Adjustment steps:

- Loosen the locknut (1).
- Insert a feeler gauge (2) between the adjuster end and the valve end.
- Turn the adjuster (3) clockwise or counter-clockwise with the valve adjusting tool (4) until the proper clearance is obtained.



Valve adjusting tool:
P/N. YM-08035, 90890-01311

- Hold the adjuster to prevent it from moving and then tighten the locknut.



Locknut:
14 Nm (1.4 m · kg, 10 ft · lb)

- Measure the valve clearance.
- If the clearance is incorrect, repeat the above steps until the proper clearance is obtained.





9.Install:

- All removed parts

NOTE:

Install all removed parts in the reverse order of their disassembly. Note the following points.

10.Install:

- Recoil starter 
- Spark plug  10 Nm (1.0 m · kg, 7.2 ft · lb)
- Tappet covers (exhaust)  18 Nm (1.8 m · kg, 13 ft · lb)
- Tappet cover (intake)  10 Nm (1.0 m · kg, 7.2 ft · lb)
- Tappet cover (intake)  10 Nm (1.0 m · kg, 7.2 ft · lb)

NOTE:

Install the intake tappet cover with the arrow pointing upward.

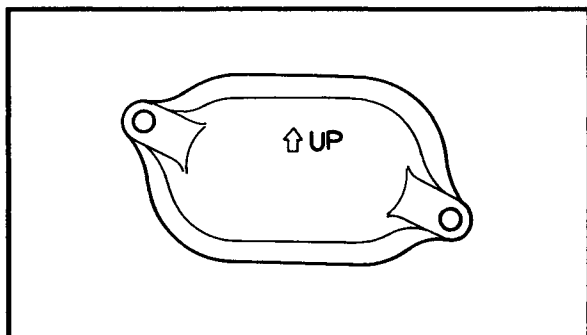

VALVE CLEARANCE ADJUSTMENT/TIMING CHAIN ADJUSTMENT/IDLING SPEED ADJUSTMENT

INSP
ADJ

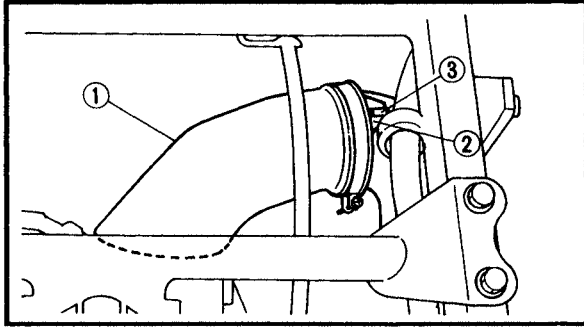

11. Install:
- Air duct ①

NOTE: _____
Install the air duct so that part ② aligns with
part ③.

12. Install:
- Fuel tank
 - Front fender
 - Front carrier
 - Seat
- Refer to "SEAT, CARRIERS, FENDERS
AND FUEL TANK".

TIMING CHAIN ADJUSTMENT

Adjustment free.

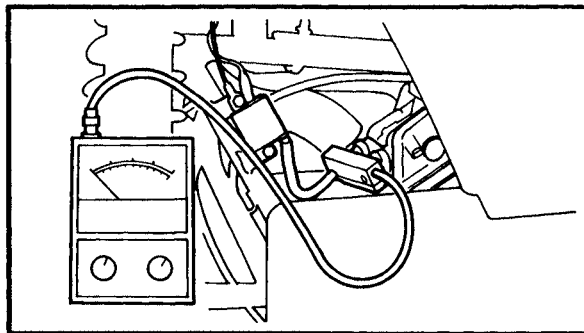

IDLING SPEED ADJUSTMENT

1. Start the engine and let it warm up for several minutes.
2. Attach:
 - Inductive tachometer or engine tachometer (to the spark plug lead)



Inductive tachometer:
P/N. YU-8036-A
Engine tachometer:
P/N. 90890-03113

3. Check:
 - Engine idling speed
Out of specification → Adjust.



Engine idling speed:
1,350 ~ 1,450 r/min

IDLING SPEED ADJUSTMENT/ THROTTLE LEVER FREE PLAY ADJUSTMENT

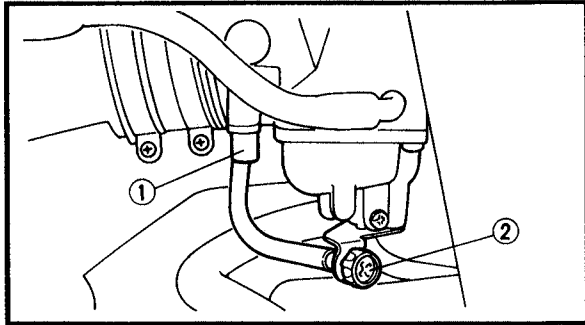

4.Adjust:

- Engine idling speed

Adjustment steps:

- Turn in the pilot screw ① until it is lightly seated.
- Turn out the pilot screw for the specified number of turns.

Pilot screw (turns out):
3 1/2

- Turn the throttle stop screw ② in or out until the specified idling speed is obtained.

Turn in	Idling speed becomes higher.
Turn out	Idling speed becomes lower.

5.Detach:

- Engine tachometer

6.Adjust:

- Throttle lever free play
Refer to "THROTTLE LEVER FREE PLAY ADJUSTMENT".

Throttle lever free play:
3 ~ 5 mm (0.12 ~ 0.20 in)

THROTTLE LEVER FREE PLAY ADJUSTMENT

NOTE: _____
Engine idling speed should be adjusted properly before adjusting the throttle lever free play.

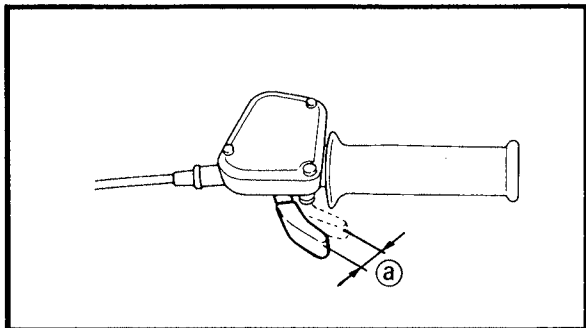

1.Check:

- Throttle lever free play ①
Out of specification → Adjust.

Throttle lever free play:
3 ~ 5 mm (0.12 ~ 0.20 in)

THROTTLE LEVER FREE PLAY ADJUSTMENT



2.Remove:

- Seat
- Front carrier
- Front fender
- Fuel tank

Refer to "SEAT, CARRIERS, FENDERS AND FUEL TANK".

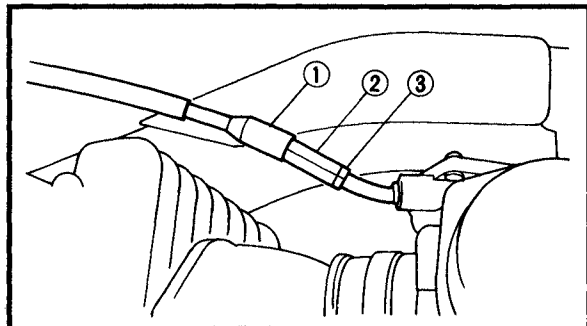

3.Adjust:

- Throttle lever free play

Adjustment steps:

First step:

- Pull back the adjuster cover ①.
- Loosen the locknut ② on the carburetor side.
- Turn the adjuster ③ in or out until the correct free play is obtained.

Turning in	Free play is increased.
Turning out	Free play is decreased.

- Tighten the locknut ②.
- Push in the adjuster cover ①.

NOTE:

_____ If the free play cannot be adjusted here, adjust it at the throttle lever side of the cable.

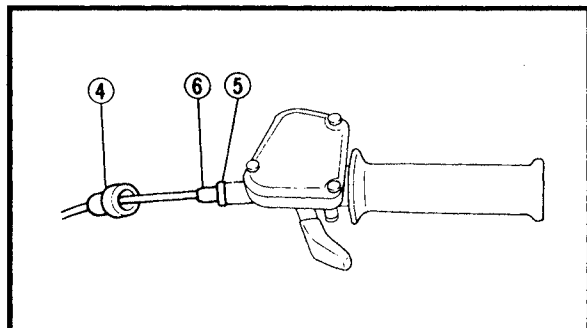

Second step:

- Pull back the adjuster cover ④.
- Loosen the locknut ⑤.
- Turn the adjuster ⑥ in or out until the correct free play is obtained.

Turning in	Free play is increased.
Turning out	Free play is decreased.

- Tighten the locknut ⑤.
- Push in the adjuster cover ④.

⚠ WARNING

_____ After adjusting the free play, turn the handlebar to the right and left to make sure that the engine idling speed does not increase.

THROTTLE LEVER FREE PLAY ADJUSTMENT/ SPEED LIMITER ADJUSTMENT



4. Install:

- Fuel tank
- Front fender
- Front carrier
- Seat

Refer to "SEAT, CARRIERS, FENDERS AND FUEL TANK".

SPEED LIMITER ADJUSTMENT

The speed limiter keeps the carburetor throttle from becoming fully-opened even when the throttle lever is applied to the maximum position. Screwing in the adjuster stops the engine speed from increasing.

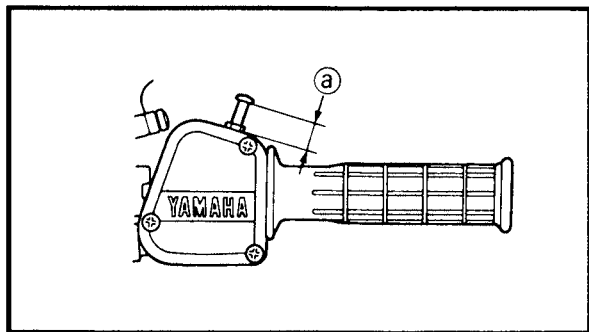

1. Check:

- Speed limiter length (a)
- Out of specification → Adjust.

	Speed limiter length: 12 mm (0.47 in)
--	--

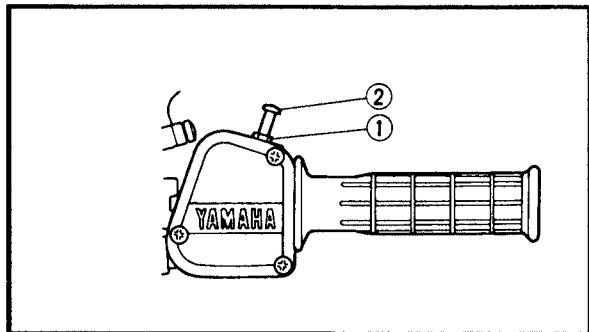

2. Adjust:

- Speed limiter length

Speed limiter length adjustment steps:

- Loosen the locknut (1).
- Turn the adjuster (2) in or out until the specified speed limiter length is obtained.

Turning in	Speed limiter length is decreased.
Turning out	Speed limiter length is increased.

- Tighten the locknut.

⚠ WARNING

- Particularly for a beginner rider, the speed limiter should be screwed in completely. Screw it out little by little as their riding technique improves. Never remove the speed limiter for a beginning rider.

SPEED LIMITER ADJUSTMENT/ SPARK PLUG INSPECTION



- For proper throttle lever operation do not turn out the adjuster more than 12 mm (0.47 in). Also, always adjust the throttle lever free play to 3 ~ 5 mm (0.12 ~ 0.20 in).

SPARK PLUG INSPECTION

1. Remove:
 - Spark plug
2. Inspect:
 - Spark plug type
Incorrect → Replace.

Standard spark plug:
for USA
DP8EA-9/NGK
for Canada
DPR8EA-9/NGK

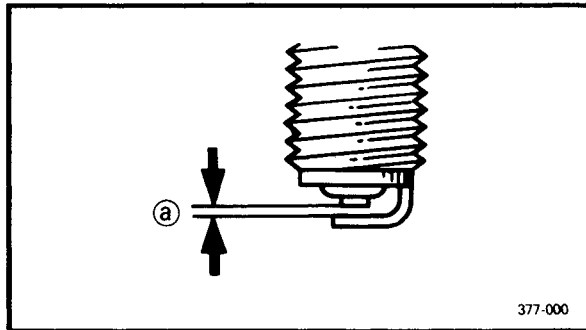
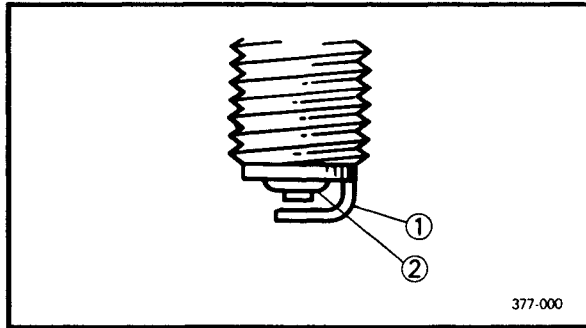

3. Inspect:
 - Electrode ①
Wear/damage → Replace.
 - Insulator ②
Abnormal color → Replace.
Normal color is a medium-to-light tan color.
4. Clean the spark plug with a spark plug cleaner or wire brush.
5. Measure:
 - Plug gap ③
Use a wire gauge or feeler gauge.
Out of specification → Regap.

 **Spark plug gap:**
0.8 ~ 0.9 mm (0.031 ~ 0.035 in)

6. Tighten:
 - Spark plug  18 Nm (1.8 m · kg, 13 ft · lb)

NOTE: _____
Before installing a spark plug, clean the gasket surface and plug surface.

IGNITION TIMING CHECK



IGNITION TIMING CHECK

NOTE:
Engine idling speed and throttle cable free play should be adjusted properly before checking the ignition timing.

1. Attach:

- Inductive tachometer or engine tachometer
- Timing light
(to spark plug lead)

	Inductive tachometer: P/N. YU-8036-A Engine tachometer: P/N. 90890-03113 Timing light: P/N. YM-33277-A, 90890-03141
---	---

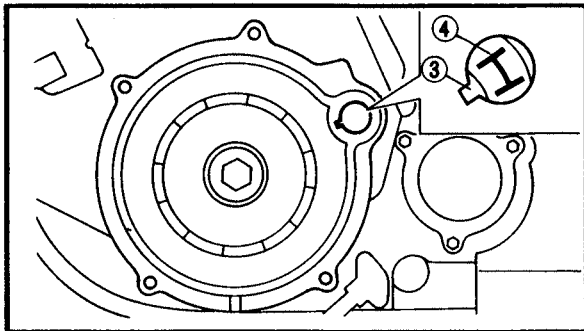
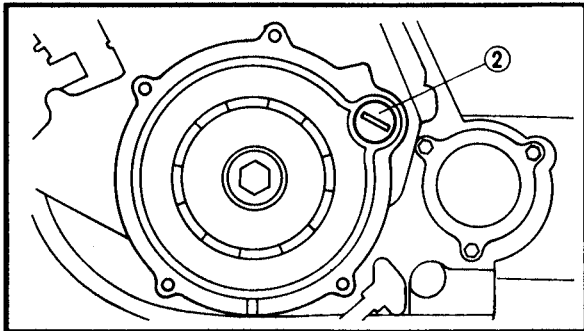
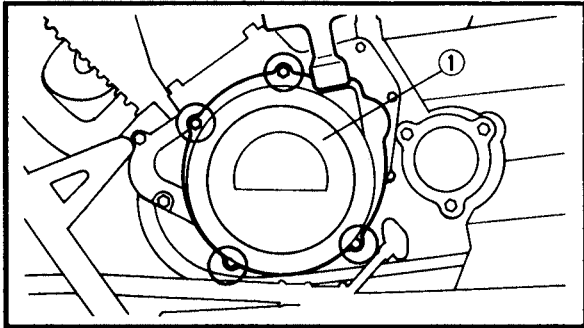

2. Check:

- Ignition timing

Checking steps:

- Warm up the engine and keep it at the specified speed.

	Engine speed: 1,350 ~ 1,450 r/min
---	---

- Remove the recoil starter ①.
- Remove the timing plug ②.
- Visually check the stationary pointer ③ to verify it is within the required firing range ④ indicated on the flywheel.
Incorrect firing range → Check the pulser coil assembly.
- Install the timing plug.
- Install the recoil starter.

	Recoil starter bolt: 10 Nm (1.0 m · kg, 7.2 ft · lb) LOCTITE®
---	--

COMPRESSION PRESSURE MEASUREMENT

NOTE: Insufficient compression pressure will result in a loss of performance.

1. Check:
 - Valve clearance
Out of specification → Adjust.
Refer to "VALVE CLEARANCE ADJUSTMENT".
2. Start the engine and let it warm up for several minutes.
3. Stop the engine.
4. Remove:
 - Spark plug
5. Attach:
 - Adapter
 - Compression gauge ①

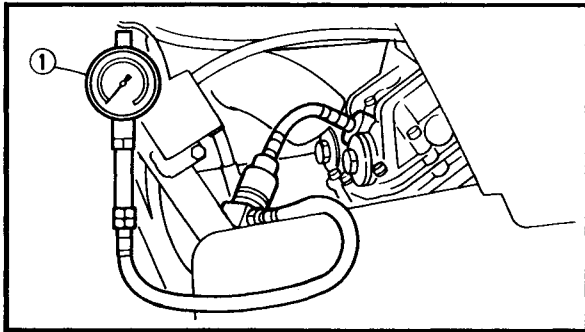

Compression gauge:
P/N. YU-33223, 90890-03081
Adapter:
P/N. YU-33223-3, 90890-04082

6. Measure:
 - Compression pressure

Above the maximum pressure:
Inspect the cylinder head, valve surfaces, and piston crown for carbon deposits.

Below the minimum pressure:
Squirt a few drops of oil into the affected cylinder and measure again.

 - Refer to the table below.

Compression pressure (with oil introduced into cylinder)	
Reading	Diagnosis
Higher than without oil	Worn or damaged pistons
Same as without oil	Defective ring(s), valves, cylinder head gasket or piston is possible.

COMPRESSION PRESSURE MEASUREMENT/ ENGINE OIL LEVEL INSPECTION



Compression pressure (at sea level):
Standard:
 850 kPa (8.5 kg/cm², 121 psi)
Minimum:
 800 kPa (8.0 kg/cm², 114 psi)
Maximum:
 900 kPa (9.0 kg/cm², 128 psi)

Measurement steps:

- Crank over the engine with the electric starter (be sure the battery is fully charged) with the throttle wide-open until the compression reading on the gauge stabilizes.

⚠ WARNING
 When cranking the engine, ground the spark plug lead to prevent sparking.

7. Install:
- Spark plug 18 Nm (1.8 m · kg, 13 ft · lb)

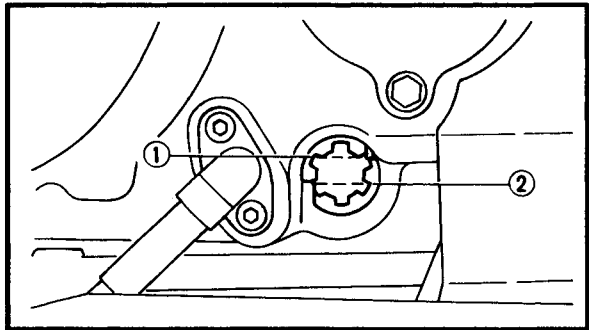

- ENGINE OIL LEVEL INSPECTION**
1. Place the machine on a level surface.
 2. Inspect:
 - Engine oil level
 - Oil level should be between the maximum ① and minimum ② marks.
 - Oil level low → Add oil to the proper level.

Recommended oil:
 Follow the left chart.

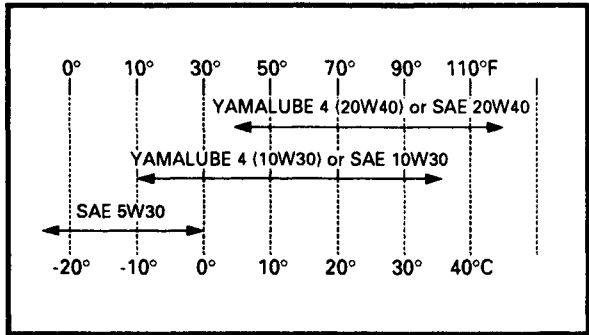

NOTE:
 Recommended oil classification:
 API Service "SE", "SF" type or equivalent
 (e.g. "SF-SE-CC", "SF-SE-SD" etc.)

CAUTION
 Do not allow foreign material to enter the crankcase.

ENGINE OIL LEVEL INSPECTION/ OIL TEMP WARNING LIGHT CHECK



3. Start the engine and let it warm up for several minutes.
4. Stop the engine and inspect the oil level again.

NOTE: _____
Wait a few minutes until the oil settles before inspecting the oil level.

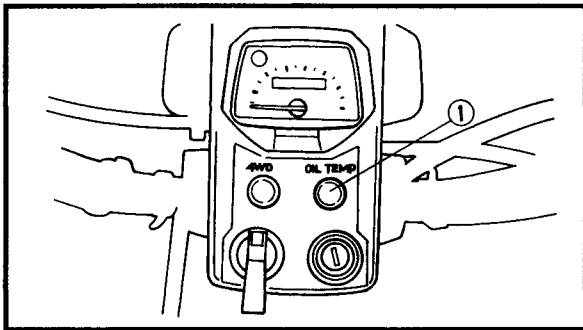

OIL TEMP WARNING LIGHT CHECK

① Oil temp indicator light

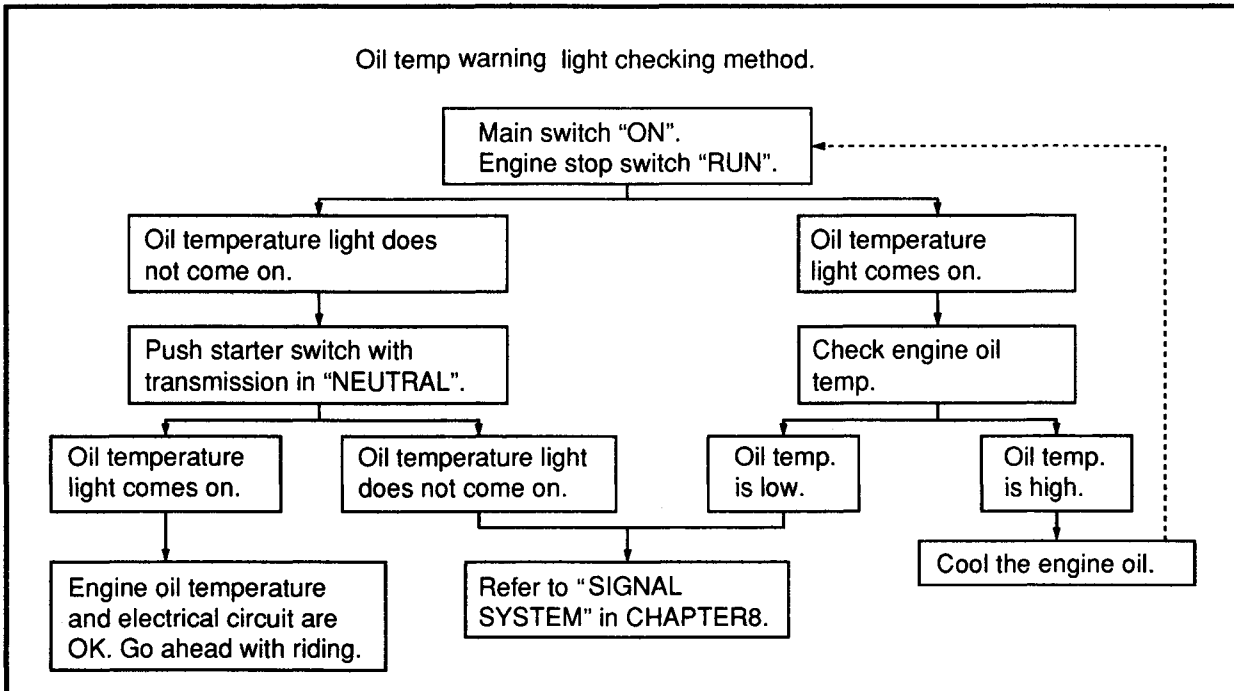

ENGINE OIL REPLACEMENT

1. Start the engine and let it warm up for several minutes.
2. Stop the engine and place an oil pan under the engine.

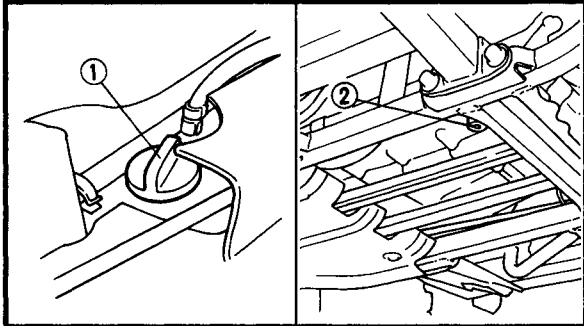

3. Remove:
 - Oil filler plug ①
 - Drain plug (engine oil) ②
 Drain the crankcase of its oil.

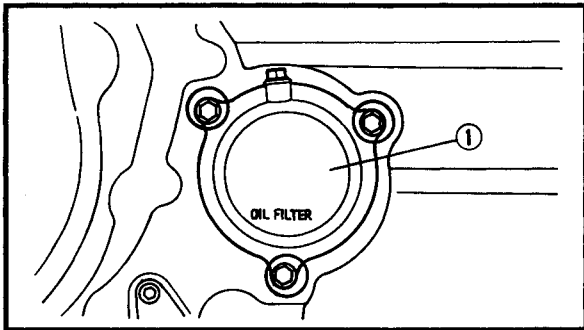

4. If the oil filter is to be replaced during this oil change, remove the following parts and then reinstall them afterwards.

Replacement steps:

- Remove the oil filter cover ① and oil filter element ②.
- Check the O-ring ③; if they are cracked or damaged, replace them with new ones.
- Install the oil filter element and oil filter cover.

	Bolt (oil filter cover): 10 Nm (1.0 m · kg, 7.2 ft · lb)
---	---

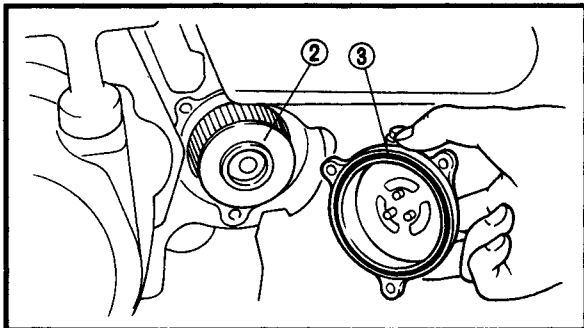

5. Install:
 - Drain plug (engine oil) ①

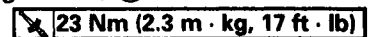
 23 Nm (2.3 m · kg, 17 ft · lb)

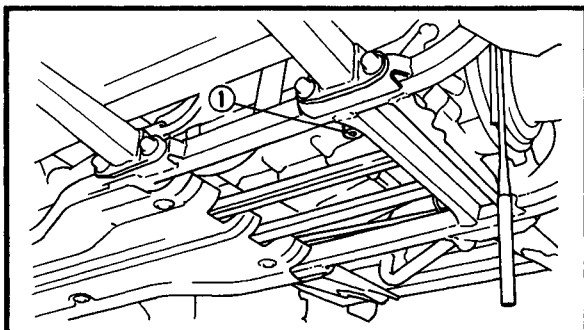

6.Fill:

- Crankcase
Refer to "ENGINE OIL LEVEL INSPECTION".

	Oil quantity:
	Total amount: 2.6 L (2.3 Imp qt, 2.7 US qt)
	Periodic oil change: 1.9 L (1.7 Imp qt, 2.0 US qt)
	With oil filter replacement: 2.0 L (1.8 Imp qt, 2.1 US qt)

7.Install:

- Oil filter plug

8.Warm up the engine for a few minutes, then stop the engine.

9.Inspect:

- Engine (for oil leaks)
- Oil level

AIR FILTER CLEANING

NOTE:

There is a check hose ① at the bottom of the air filter case. If dust and/or water collects in this hose, clean the air filter element and air filter case.

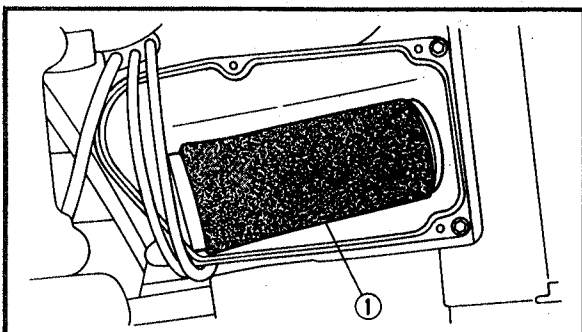
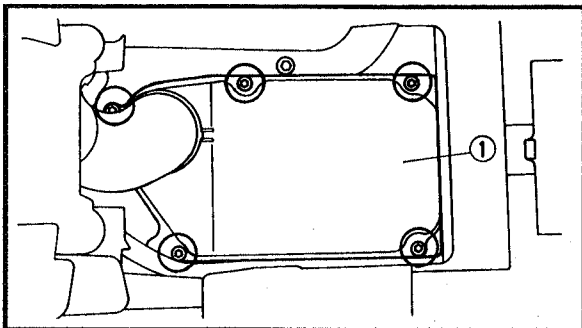
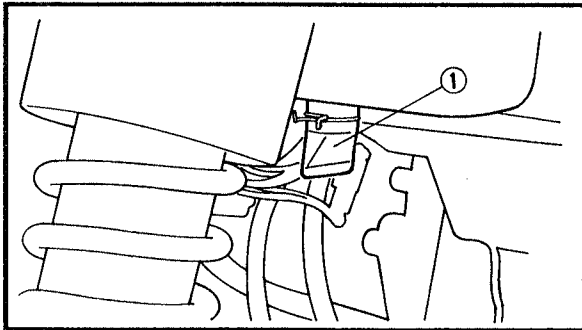

1.Remove:

- Seat
Refer to "SEAT, CARRIERS, FENDERS AND FUEL TANK".
- Air filter case cover ①

2.Remove:

- Air filter element assembly ①
- Air filter element cap
- Air filter element

NOTE:

When removing the air filter element, rotate the air filter element cap 1/4 of a turn and remove the element.

AIR FILTER CLEANING

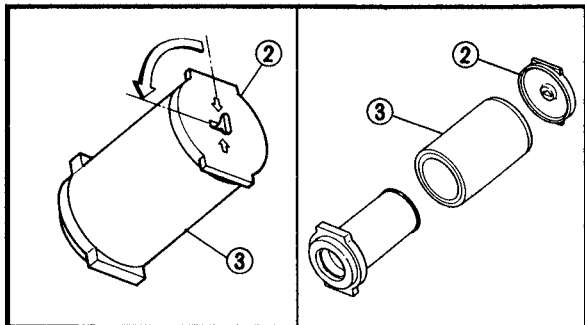

- ② Air filter element cap
- ③ Air filter element

CAUTION:

Never operate the engine with the air filter element removed. This will allow unfiltered air to enter, causing rapid wear and possible engine damage. Additionally, operation without the filter element will affect carburetor tuning with subsequent poor performance and possible engine overheating.

3. Inspect:

- Air filter element
- Damaged → Replace.

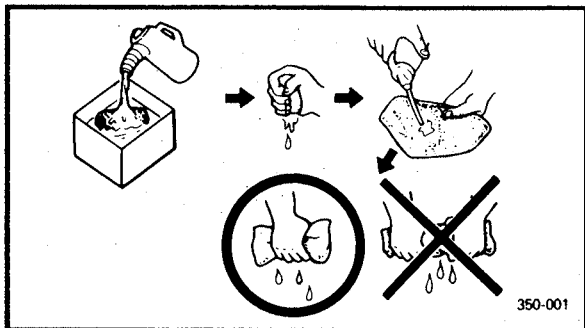

4. Clean:

- Air filter element

Cleaning steps:

- Wash the element gently, but thoroughly in solvent.

WARNING

Use a cleaning solvent which is designed to clean parts only. Never use gasoline or low flash point solvents as they may cause a fire or explosion.

- Squeeze the excess solvent out of the element and let it dry.

CAUTION:

Do not twist or wring out the element. This could damage the foam material.

- Apply engine oil to the element.
- Squeeze out the excess oil.

NOTE:

The element should be wet but not dripping.

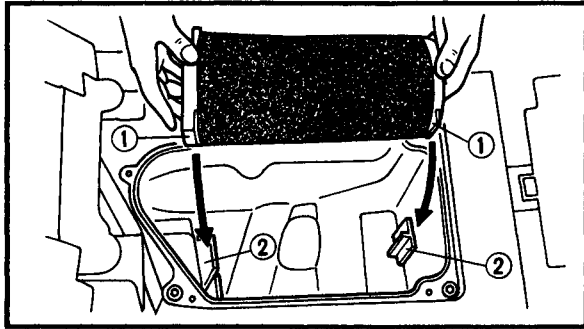

5. Install:
- Air filter element
 - Air filter case cover
 - Seat

NOTE:

- Insert the lobes ① on the filter element into the receptacles ② on the filter case.
- To prevent air leaks make sure that the sealing surface of the element matches the sealing surface of the case.

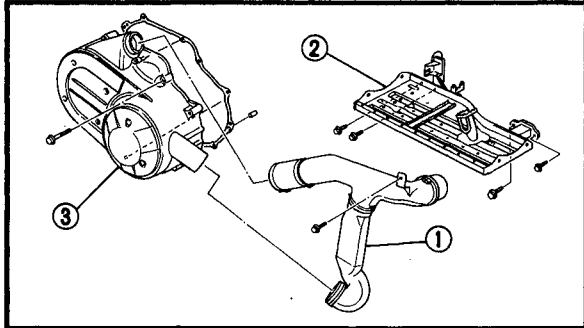

V-BELT INSPECTION

1. Remove:

- Air duct assembly ①
 - Footlest board (right) ②
 - Crankcase cover (right) ③
- Refer to "PRIMARY AND SECONDARY SHEAVES" in CHAPTER 4.

2. Inspect:

- V-belt ①
Cracks/Wear/Scaling/Chipping → Replace.
Oil/Grease → Check primary sheave and secondary sheave.

3. Measure:

- V-belt width ②
Out of specification → Replace.

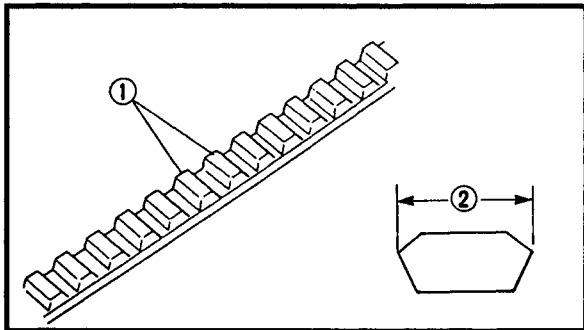

	V-belt width:
	32.0 mm (1.26 in)
	<Limit:> 30 mm (1.18 in)

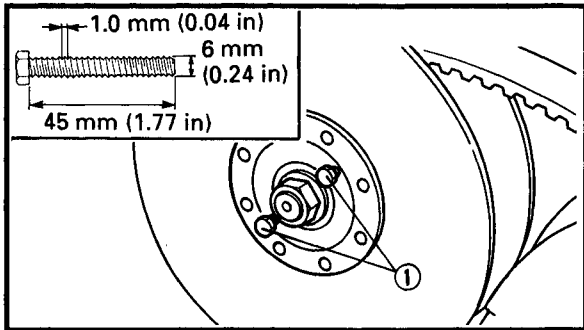

4. Replace:

- V-belt

Replacing steps:

- Install the bolts ① (90101-06016) into the secondary fixed sheave hold

NOTE:

Tightening the bolts ① will push the secondary sliding sheave away causing the gap between the secondary fixed and sliding sheaves to widen.

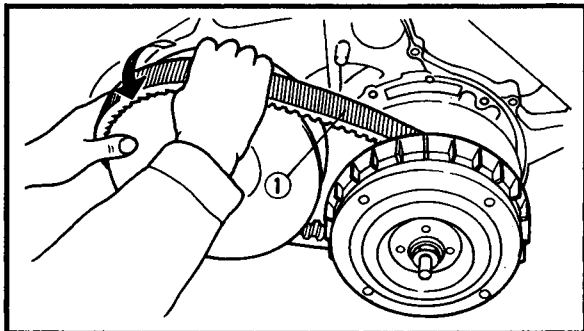

- Remove the V-belt ① from the primary sheave and secondary sheave.

V-BELT INSPECTION

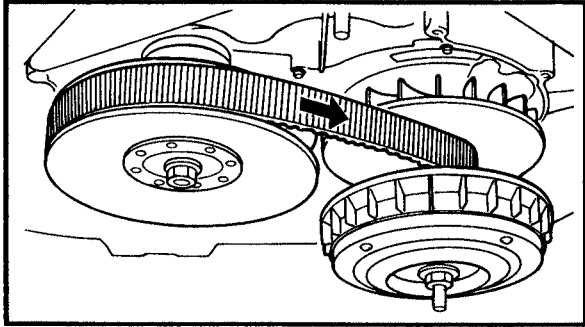

- Install the V-belt.

NOTE: _____
Install the V-belt so that its arrow faces the direction shown in the illustration.

- Remove the Bolts.

FRONT BRAKE ADJUSTMENT/ REAR BRAKE LEVER AND PEDAL ADJUSTMENT

**INSP
ADJ**

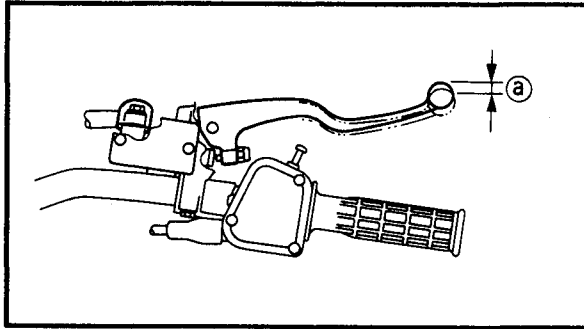

CHASSIS

FRONT BRAKE ADJUSTMENT

1. Check:

- Brake lever free play (a)
- Out of specification → Adjust.



Free play:
2 ~ 5 mm (0.08 ~ 0.20 in)
(at brake lever end)

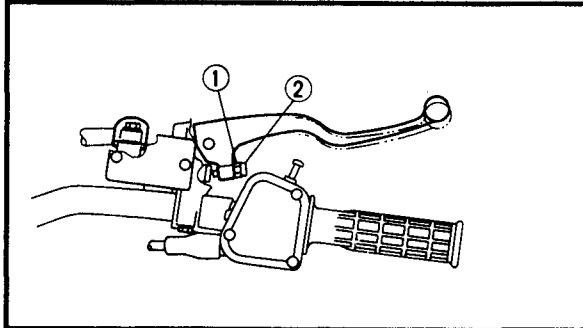

2. Adjust:

- Brake lever free play

Adjustment steps:

- Loosen the locknut (1).
- Turn the adjuster (2) in or out until the specified free play is obtained.

Turning in	Free play is decreased.
Turning out	Free play is increased.

- Tighten the locknut.

CAUTION:

Make sure that the brake does not drag after adjusting it.

WARNING

A soft or spongy feeling in the brake lever can indicate the presence of air in the brake system. This air must be removed by bleeding the brake system before the machine is operated. Air in the system will cause a greatly diminished braking capability and can result in a loss of control and an accident. Inspect and if necessary bleed the system.

REAR BRAKE LEVER AND PEDAL ADJUSTMENT

WARNING

Always adjust both the brake pedal and the rear brake lever whenever adjusting the rear brake.

REAR BRAKE LEVER AND PEDAL ADJUSTMENT

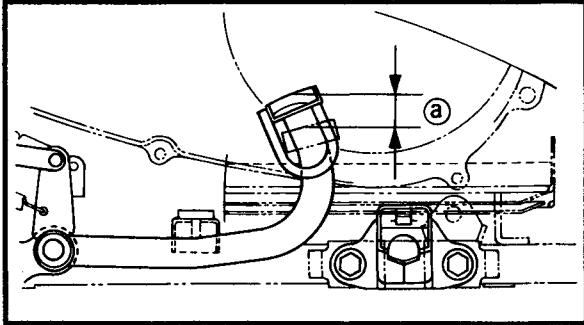

1. Check:

- Rear brake pedal free play **a**
 - Rear brake lever free play **b**
- Out of specification → Adjust.

	Rear brake pedal free play a: 20 ~ 30 mm (0.8 ~ 1.2 in)
	Rear brake lever free play b: 5 ~ 7 mm (0.20 ~ 0.28 in)

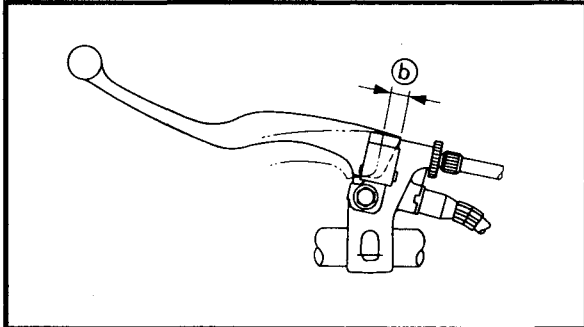

2. Adjust:

- Free play (rear brake lever)
- Free play (brake pedal)

Rear brake lever and brake pedal free play adjustment steps:

NOTE:

Before adjusting the free play, pump the brake pedal 2 to 3 times.

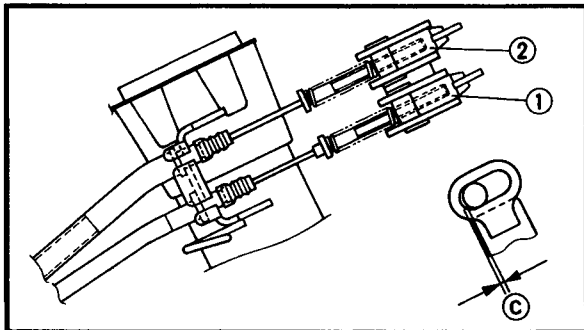

- Fully loosen the brake lever cable adjuster (drum) ①.
- Turn the rear brake pedal rod adjuster ② until the brake pedal free play is within the specified limits.

	Free play (brake pedal): 20 ~ 30 mm (0.8 ~ 1.2 in)
--	--

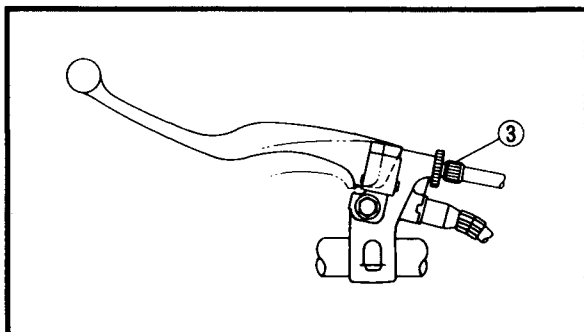

- Fully screw in the brake lever cable adjuster (handlebar) ③.
- Turn the brake lever cable adjuster (drum) ① clockwise until the gap ③ is within the specified limits.

	Gap ③: Zero ~ 1 mm (0.00 ~ 0.04 in)
--	---

REAR BRAKE LEVER AND PEDAL ADJUSTMENT/ FRONT BRAKE FLUID LEVEL INSPECTION

INSP
ADJ

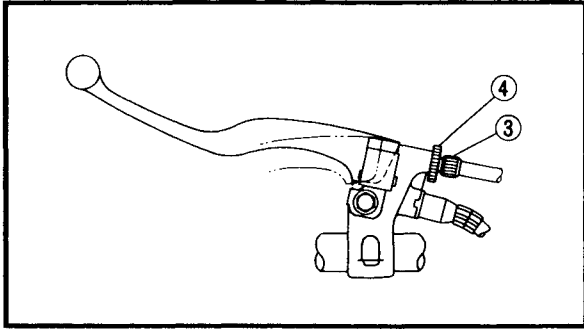

- Inspect the free play (brake pedal) to see whether or not it is within the specified limits. If not, perform the above steps again.



Free play (brake pedal):
20 ~ 30 mm (0.8 ~ 1.2 in)

- Loosen the locknut (handlebar) ④.
- Turn the brake lever cable adjuster (handlebar) ③ until the free play (brake lever) is within the specified limits.



Free play (brake lever):
5 ~ 7 mm (0.20 ~ 0.28 in)

- Tighten the locknut (handlebar) ④.

⚠ WARNING

After this adjustment is performed, lift the front and rear wheels off the ground by placing a block under the engine, and spin the rear wheels to ensure there is no brake drag. If any brake drag is noticed perform the above steps again.

FRONT BRAKE FLUID LEVEL INSPECTION

1. Place the machine on a level surface.

NOTE:

When inspecting the front brake fluid level, make sure that the top of the master cylinder top is horizontal.

2. Inspect:

- Brake fluid level
Fluid level is under "LOWER" level line ①
→ Fill up.

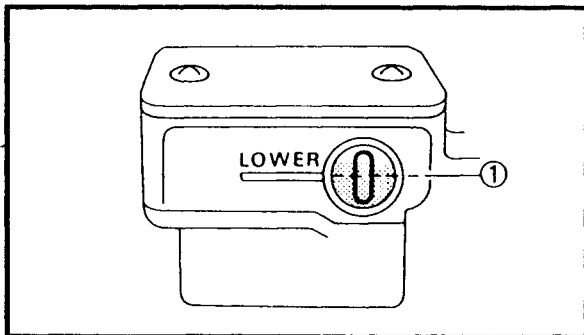

Recommended brake fluid:
DOT 4

NOTE:

If DOT 4 is not available, DOT 3 can be used.

CAUTION:

Brake fluid may erode painted surfaces or plastic parts. Always clean up spilled fluid immediately.

⚠ WARNING

- Use only the designed quality brake fluid; otherwise, the rubber seals may deteriorate, causing leakage and poor brake performance.
- Refill with the same type of brake fluid; mixing fluids may result in a harmful chemical reaction and lead to poor performance.
- Be careful that water does not enter the master cylinder when refilling. Water will significantly lower the boiling point of the fluid and may result in a vapor lock.

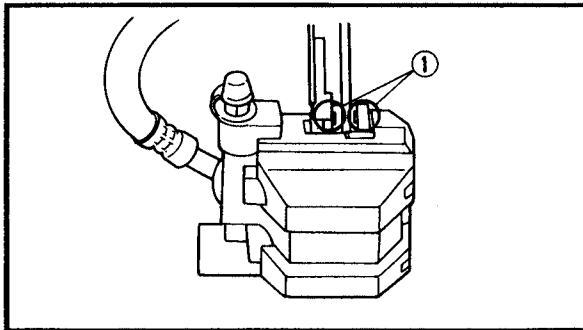

FRONT BRAKE PAD INSPECTION

1. Remove:
 - Front wheels
2. Inspect:
 - Brake padWear indicators ① almost touch the brake disc → Replace the brake pads as a set. Refer to "FRONT AND REAR WHEELS" in CHAPTER 7.
3. Operate the brake lever.
4. Install:
 - Front wheels

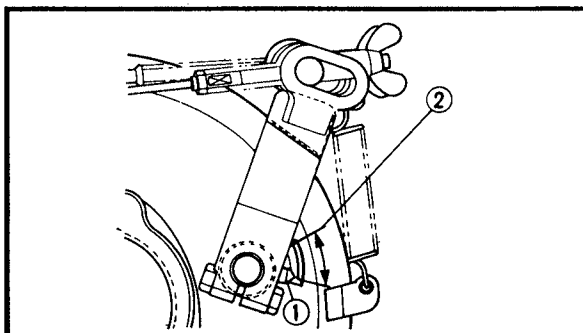

REAR BRAKE SHOE INSPECTION

1. Operate the rear brake lever or brake pedal.
2. Inspect:
 - Wear indicator ① reaches the wear limit line ② → Replace the shoes as a set. Refer to "REAR BRAKE" in CHAPTER 7.

BRAKE HOSE INSPECTION/ AIR BLEEDING (HYDRAULIC BRAKE SYSTEM)



BRAKE HOSE INSPECTION

1. Remove:

- Seat
- Front carrier
- Front fender

Refer to "SEAT, CARRIERS, FENDERS AND FUEL TANK".

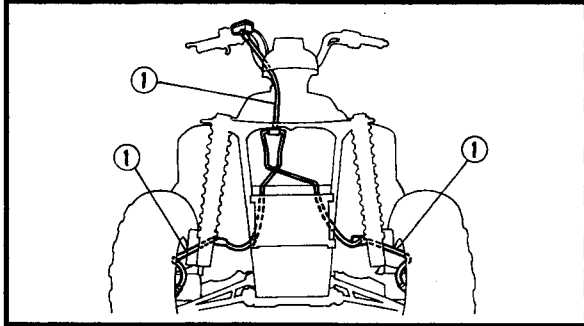

2. Inspect:

- Brake hoses ①
Cracks/wear/damage → Replace.

3. Check:

- Brake hose clamp
Loosen → Tighten.

4. Hold the machine in an upright position and apply the front or rear brake.

5. Check:

- Brake hoses
Active the brake lever several times.
Fluid leakage → Replace the hose.
Refer to "FRONT BRAKE" in CHAPTER 7.

6. Install:

- Front fender
- Front carrier
- Seat

Refer to "SEAT, CARRIERS, FENDERS AND FUEL TANK".

AIR BLEEDING (HYDRAULIC BRAKE SYSTEM)

⚠ WARNING

Bleed the brake system if:

- The system has been disassembled.
- A brake hose or brake pipe have been loosened or removed.
- The brake fluid has been very low.
- The brake operation has been faulty.

A loss of braking performance may occur if the brake system is not properly bled.

AIR BLEEDING (HYDRAULIC BRAKE SYSTEM)

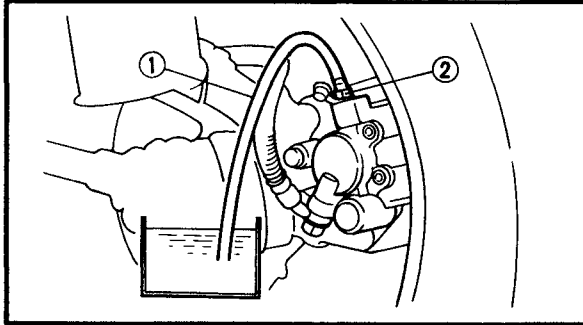

1. Bleed:

- Brake system

Air bleeding steps:

- Add the proper brake fluid to the reservoir.
- Install the diaphragm. Be careful not to spill any fluid or allow the reservoir to overflow.
- Connect the clear plastic hose ① tightly to the caliper bleed screw ②.
- Place the other end of the hose into a container.
- Slowly apply the brake lever several times.
- Pull the lever in and hold it.
- Loosen the bleed screw and allow the lever to travel towards its limit.
- Tighten the bleed screw when the lever limit has been reached, then release the lever.
- Repeat steps (e) to (h) until all the air bubbles have disappeared from the fluid.
- Tighten the bleed screw.



Bleed screw:

6 Nm (0.6 m • kg, 4.3 ft • lb)

NOTE:

If bleeding is difficult, it may be necessary to let the brake fluid settle for a few hours. Repeat the bleeding procedure when the tiny bubbles in the system have disappeared.

- Add brake fluid to proper level.
Refer to "BRAKE FLUID LEVEL INSPECTION".

⚠ WARNING

Check the operation of the brake after bleeding the brake system.

SELECT LEVER CONTROL CABLE AND SHIFT ROD ADJUSTMENT

**INSP
ADJ**

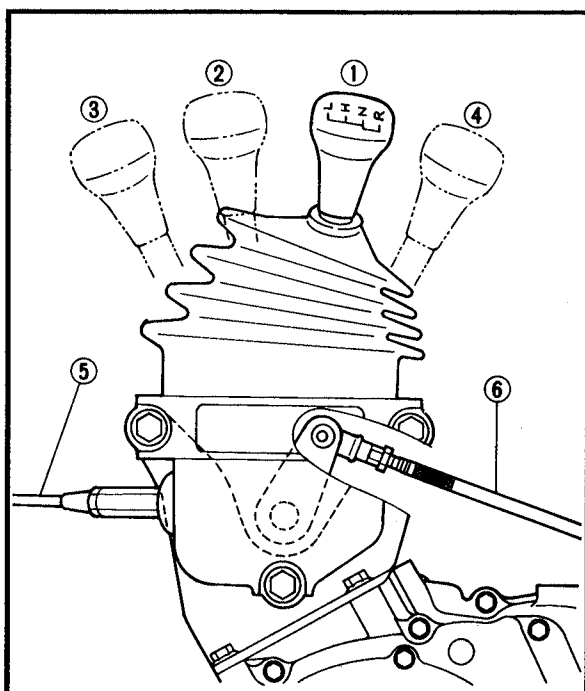

SELECT LEVER CONTROL CABLE AND SHIFT ROD ADJUSTMENT

- ① NEUTRAL
- ② HIGH
- ③ LOW
- ④ REVERSE
- ⑤ Control cable
- ⑥ SELECT LEVER shift rod

⚠ WARNING

Before moving the select lever, bring the machine to a complete stop and return the throttle lever to its closed position. Otherwise the transmission may be damaged.

1. Adjust:

- Rear brake pedal free play
Refer to "REAR BRAKE LEVER AND PEDAL ADJUSTMENT".

2. Adjust:

- Select lever control cable
- Select lever shift rod

Select lever control cable and select lever shift rod adjustment steps:

Control cable:

- Make sure that the select lever is NEUTRAL.
- Adjust the control cable so there is zero free play in the cable. When the adjustment is correct, slack in the return spring ① will be taken up.

NOTE:

In some cases it will be necessary to further adjust the cable with the locknuts ② arrangement that holds the cable to its mount.

- When the brake begins to work "③=20 ~ 30 mm (0.8 ~ 1.2 in)", verify that the select lever can be shifted to REVERSE from NEUTRAL and to NEUTRAL from REVERSE

- Before the brake begins to work "③=0 ~ 20 mm (0 ~ 0.8 in)", verify that the select lever cannot be shifted to REVERSE from NEUTRAL and to NEUTRAL from REVERSE.

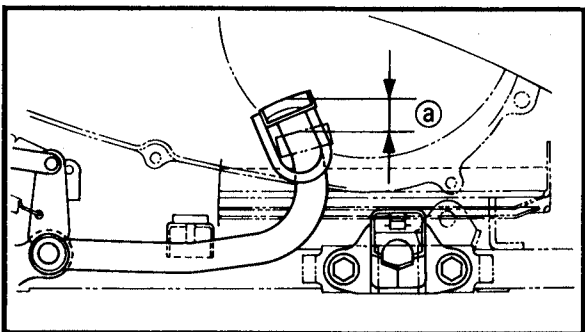
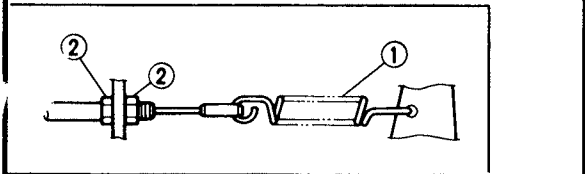
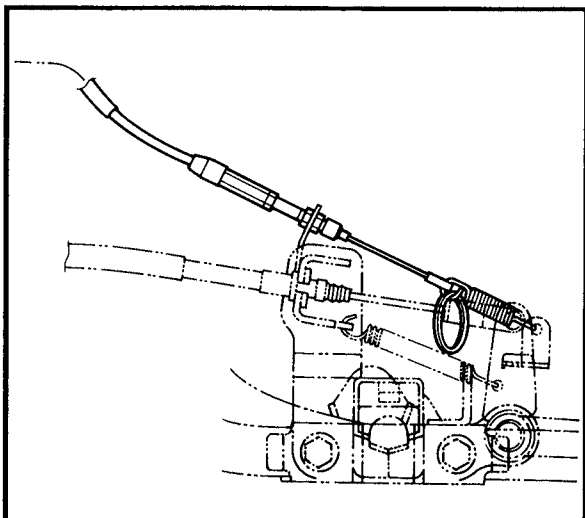

**SELECT LEVER CONTROL CABLE AND SHIFT ROD ADJUSTMENT/
FINAL GEAR OIL LEVEL INSPECTION/
FINAL GEAR REPLACEMENT**

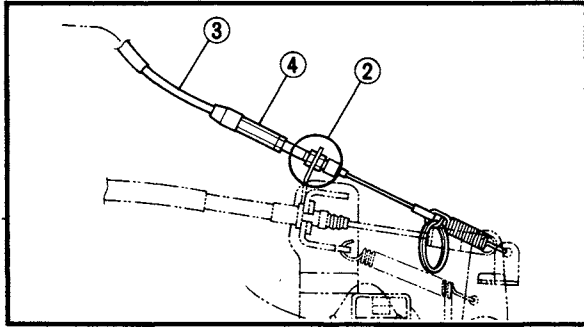

- Check that locknuts ② are tightened correctly.
- If the operation of the select lever is incorrect, adjust the select lever control cable ③ with the adjuster ④.

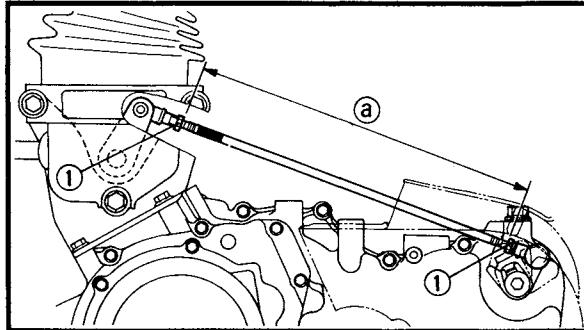

Select lever shift rod:

- Make sure that the select lever is NEUTRAL.
- Loosen both locknuts ①.
- Adjust the shift rod length ②.

**Select lever shift rod length:
274 mm (10.8 in)**

- Tighten the locknuts ①.

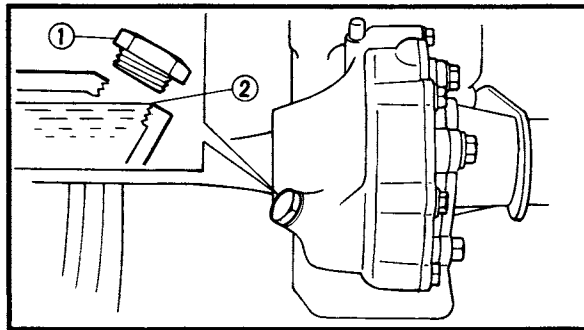

FINAL GEAR OIL LEVEL INSPECTION

1. Place the machine on a level place.
2. Remove:
 - Oil filler bolt ①
3. Inspect:
 - Oil level
 - Oil level should be up to bottom brim ② of hole.
 - Oil level low → Add oil to proper level.

**Recommended oil:
SAE80 API "GL-4" Hypoid gear oil**

CAUTION:

Take care not allow foreign material to enter the final gear case.

4. Install:
 - Oil filler bolt 23 Nm (2.3 m · kg, 17 ft · lb)

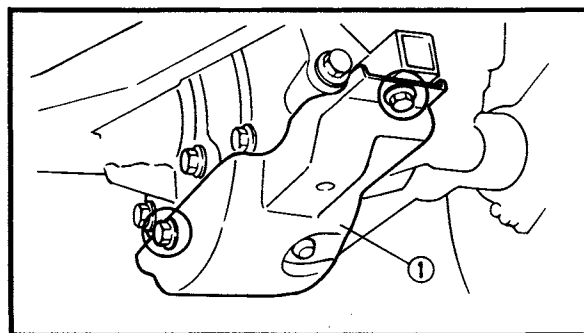

FINAL GEAR REPLACEMENT

1. Place the machine on a level surface.
2. Remove:
 - Final gear case protector ①
3. Place a receptacle under the final gear case.

FINAL GEAR REPLACEMENT/ DIFFERENTIAL GEAR OIL REPLACEMENT

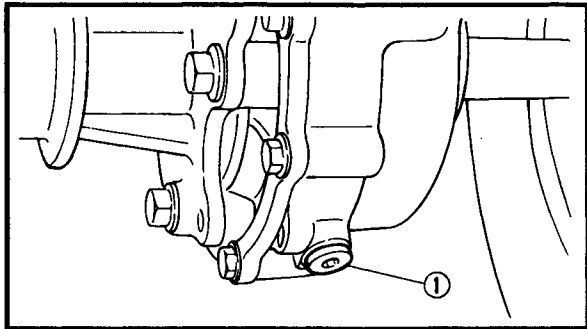

- 4.Remove:
- Oil filler bolt
 - Drain plug ①
- 5.Drain:
- Final gear oil

6.Install:

- Drain plug 23 Nm (2.3 m · kg, 17 ft · lb)

NOTE:

Check the gasket (drain plug). If it is damaged, replace it with a new one.

7.Fill:

- Final gear case



Periodic oil change:
0.19 L (0.17 Imp qt, 0.20 US qt)
Total amount:
0.22 L (0.20 Imp qt, 0.23 US qt)
Recommended oil:
SAE80 API "GL-4" Hypoid gear oil

CAUTION:

Take care not to allow foreign material to enter the final gear case.

8.Inspect:

- Oil level
Refer to "FINAL GEAR OIL LEVEL INSPECTION".

9.Install:

- Oil filler bolt 23 Nm (2.3 m · kg, 17 ft · lb)
- Final gear case protector 16 Nm (1.6 m · kg, 11 ft · lb)

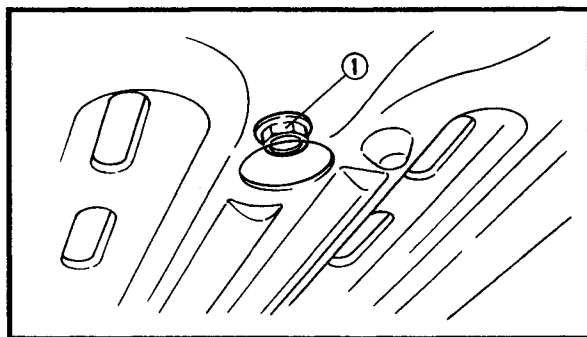

DIFFERENTIAL GEAR OIL REPLACEMENT

- 1.Place the machine on a level surface.
- 2.Place a receptacle under the differential gear case.
- 3.Remove:
 - Oil filler bolt
 - Drain plug ①

4. Drain:

- Differential gear oil

5. Install:

- Drain plug  19 Nm (1.9 m · kg, 13 ft · lb)

NOTE:

Check the gasket (drain plug). If it is damaged, replace it with new one.

6. Fill:

- Differential gear case



Periodic oil change:

0.7 L (0.62 Imp qt, 0.74 US qt)

Total amount:

0.67 L (0.59 Imp qt, 0.71 US qt)

Recommended oil:

SAE 80 API "GL-4" Hypoid gear oil

CAUTION

Take care not to allow foreign material to enter the differential gear case.

7. Install:

- Oil filler bolt  23 Nm (2.3 m · kg, 17 ft · lb)

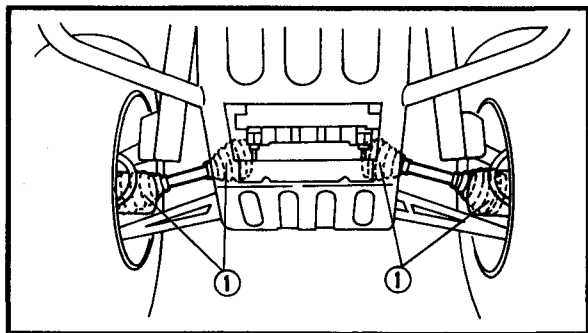

CONSTANT VELOCITY JOINT DUST BOOT INSPECTION

1. Inspect:

- Dust boots ①

Damage → Replace.

Refer to "DIFFERENTIAL GEAR AND CONSTANT VELOCITY JOINT" in CHAPTER 6.

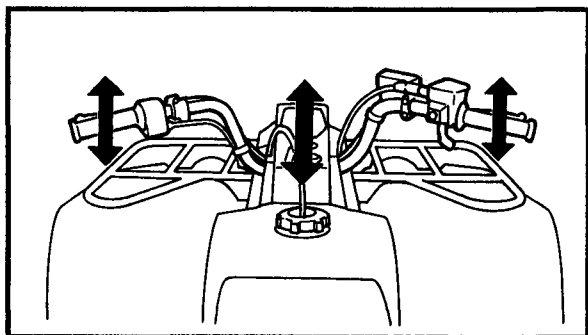

STEERING SYSTEM INSPECTION

1. Place the machine on a level surface.

2. Check:

- Steering assembly bushings

Move the handlebar up and down, and/or back and forth.

Excessive play → Replace the steering stem bushings.

STEERING SYSTEM INSPECTION/ TOE-IN ADJUSTMENT

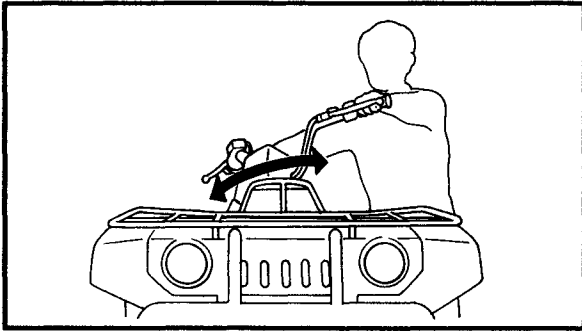

3. Check:

- Tie-rod ends
Turn the handlebar to the left and/or right until it stops completely then move the handlebar from the left to the right slightly. Tie-rod end ① has any vertical play → Replace the tie-rod end(s).

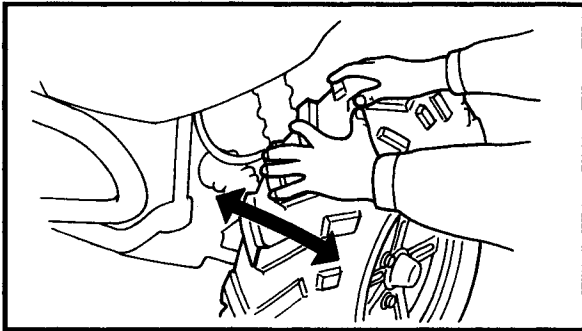
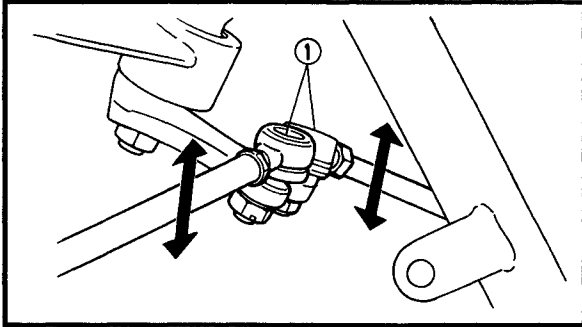

4. Raise the front end of the machine so that there is no weight on the front wheels.

5. Check:

- Ball joints and/or wheel bearings
Move the wheels laterally back and forth. Excessive free play → Replace the front arms (upper and lower) and/or wheel bearings.

TOE-IN ADJUSTMENT

1. Place the machine on a level surface.

2. Measure:

- Toe-in
Out of specification → Adjust.

	Toe-in: -5 ~ 5 mm (-0.20 ~ 0.20 in)
--	---

Toe-in measurement steps:

NOTE: _____
Before measuring the toe-in, make sure that the tire pressure is correct.

- Mark both front tire tread centers.
- Raise the front end of the machine so that there is no weight on the front tires.
- Face the handlebar straight ahead.

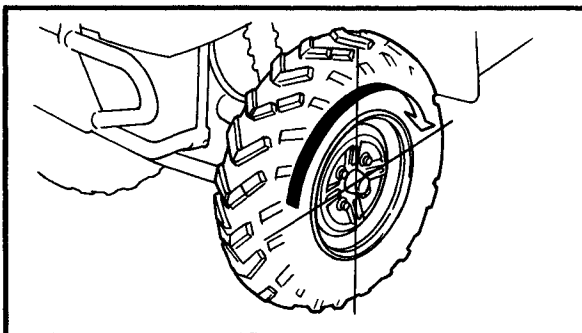

TOE-IN ADJUSTMENT

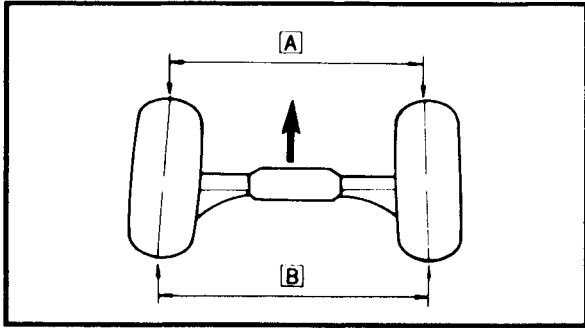

- Measure the width [A] between the marks.
- Rotate the front tires 180° until the marks are exactly opposite one another.
- Measure the width [B] between the marks.
- Calculate the toe-in using the formula given below.

$\text{Toe-in} = [B] - [A]$

- If the toe-in is incorrect, adjust it.

3.Adjust:

- Toe-in

⚠ WARNING

- Be sure that both tie-rods are turned the same amount. If not, the machine will drift right or left even though the handlebar is positioned straight. This may lead to mishandling and an accident.
- After setting the toe-in to specification, run the machine slowly for some distance with both hands lightly holding the handlebar and check that the handlebar responds correctly. If not, turn either the right or left tie-rod within the toe-in specification.

Adjustment steps:

- Mark both tie-rods ends.
This reference point will be needed during adjustment.
- Loosen the locknuts (tie-rod end) ① of both tie-rods.
- The same number of turns should be given to both the right and left tie-rods ② until the specified toe-in is obtained. This is to keep the length of the rods the same.
- Tighten the rod end locknuts of both tie rods.

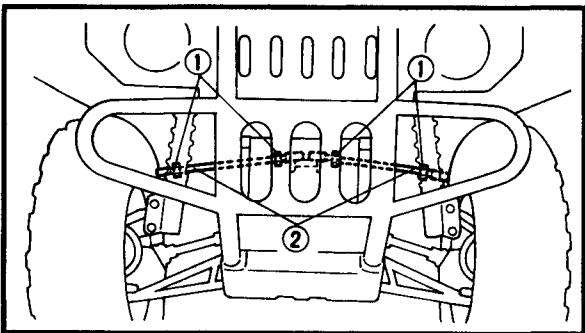

	Locknut (rod end): 15 Nm (1.5 m · kg, 11 ft · lb)
--	--

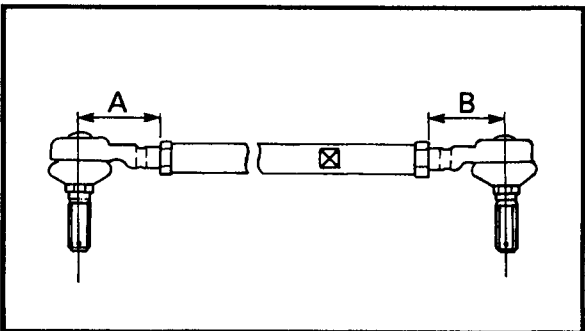

NOTE: _____
Adjust the rod ends so that A and B are equal.

REAR SHOCK ABSORBER ADJUSTMENT/ TIRE INSPECTION

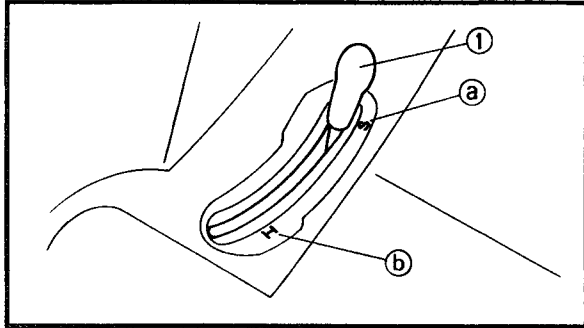

REAR SHOCK ABSORBER ADJUSTMENT

1. Adjust:

- Spring preload
Turn the adjusting lever ① to soft ② or hard ③ the spring preload.

NOTE:

The spring preload of the rear shock absorber can be adjusted to suit the rider's preference, weight, and the riding conditions.

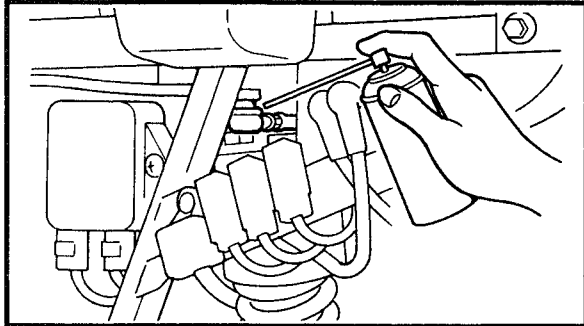

2. Lubricate:

- Adjusting lever pivot



Recommended lubricant:

Ball joint:

Yamaha chain and cable lube or engine oil

Lever pivot:

Lithium soap base grease

TIRE INSPECTION

⚠ WARNING

This model is equipped with low pressure tires. It is important that they be inflated correctly and maintained at the proper pressures.

• TIRE CHARACTERISTICS

- 1) Tire characteristics influence the handling of ATV's. The tires listed below have been approved by Yamaha Motor Co., Ltd. for this model. If other tire combinations are used, they can adversely affect your machine's handling characteristics and are therefore not recommended.

	Manufacturer	Size	Type
Front	DUNLOP	AT25×8-12	KT122
Rear	DUNLOP	AT25×10-10	KT126

• TIRE PRESSURE

- 1) Recommended tire pressure

Front 30 kPa (0.30 kg/cm², 4.3 psi)

Rear 27.5 kPa (0.275 kg/cm², 4.0 psi)

2) Tire pressure below the minimum specification could cause the tire to dislodge from the rim under severe riding conditions.

The following are minimums:

Front 27 kPa (0.27 kg/cm², 3.9 psi)

Rear 24.5 kPa (0.245 kg/cm², 3.5 psi)

3) Use no more than

Front 33 kPa (0.33 kg/cm², 4.7 psi)

Rear 30.5 kPa (0.305 kg/cm², 4.3 psi)

when seating the tire beads. Higher pressures may cause the tire to burst.

Inflate the tires slowly and carefully.

Fast inflation could cause the tire to burst.

• **MAXIMUM LOADING LIMIT**

1) Vehicle load limits: 220 kg (485 lb)*

* Total weight of the cargo, trailer hitch vertical load, rider, and accessories.

2) Storage box: 2 kg (4.4 lb)

3) Trailer hitch:

Horizontal load: 550 kg (1,212 lb)

Total weight of the trailer and cargo.

Vertical load: 15 kg (33 lb)

Vertical weight on the trailer hitch joint.

Be extra careful of the machine balance and stability when towing a trailer.

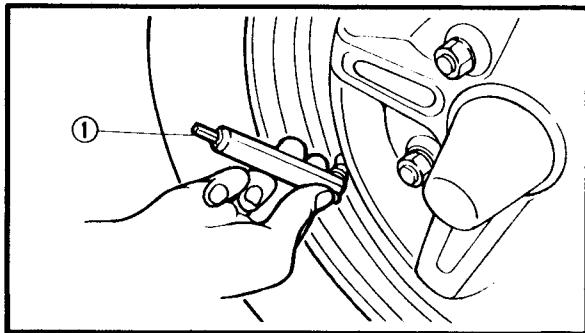

1. Measure:

- Tire pressure (cold tire pressure)
Out of specification → Adjust.

NOTE:

- The low-pressure tire gauge ① is included as standard equipment.
- If dust or the like is stuck to this gauge, it will not provide the correct readings. Therefore, take two measurements of the tire's pressure and use the second reading.

Cold tire pressure	Front	Rear
Standard	30 kPa (0.30 kg/cm ² , 4.3 psi)	27.5 kPa (0.275 kg/cm ² , 4.0 psi)
Minimum	27 kPa (0.27 kg/cm ² , 3.8 psi)	24.5 kPa (0.245 kg/cm ² , 3.5 psi)
Maximum	33 kPa (0.33 kg/cm ² , 4.7 psi)	30.5 kPa (0.305 kg/cm ² , 4.3 psi)

⚠ WARNING

Uneven or improper tire pressure may adversely affect the handling of this machine and may cause loss of control.

- Maintain proper tire pressures.
- Set tire pressures when the tires are cold.
- Tire pressures must be equal in both front tires and equal in both rear tires.

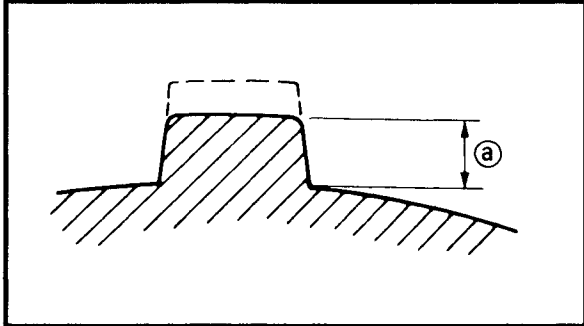

2. Inspect:

- Tire surfaces
Wear/damage → Replace.



Tire wear limit [Ⓐ]:
Front and rear: 3.0 mm (0.12 in)

⚠ WARNING

It is dangerous to ride with a worn-out tire. When tire wear is out of specification, replace the tire immediately.

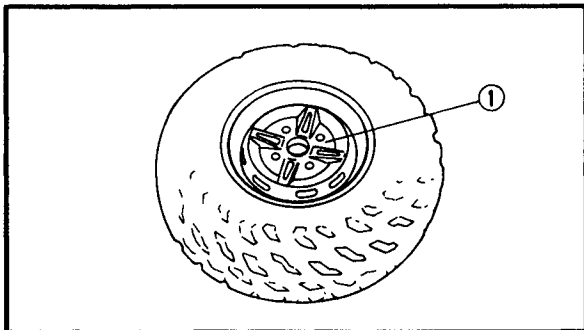

WHEEL INSPECTION

1. Inspect:

- Wheels ①
Damage/bends → Replace.

NOTE:

Always balance the wheel when a tire or wheel has been changed or replaced.

⚠ WARNING

- Never attempt even small repairs to the wheel.
- Ride conservatively after installing a tire to allow it to seat itself properly on the rim.

CABLE INSPECTION AND LUBRICATION

⚠ WARNING

A damaged cable sheath may cause corrosion and interfere with the cable movement. An unsafe condition may result so replace a damaged cable as soon as possible.

1. Inspect:

- Cable sheath
Damage → Replace.

2. Check:

- Cable operation
Unsmooth operation → Lubricate or replace.

	Recommended lubricant: Yamaha chain and cable lube or Engine oil
---	---

NOTE:

Hold the cable end up and apply several drops of lubricant to the cable.

3. Apply:

- Lithium soap base grease
(onto end of the cable)

LEVERS, PEDAL, ETC. LUBRICATION

1. Lubricate the pivoting parts.

	Recommended lubricant: Yamaha chain and cable lube or Engine oil
---	---

EB305000

ELECTRICAL**BATTERY INSPECTION****NOTE:**

Since the MF battery is a sealed type battery, it is not possible to measure the specific gravity of the electrolyte in order to check the charge state of the battery. Therefore the charge of the battery has to be checked by measuring the voltage at the battery terminals.

CAUTION:**CHARGING METHOD**

- This is a sealed type battery. Never remove the sealing caps. If the sealing caps have been removed, the balance will not be maintained and battery performance will deteriorate.
 - Charging time, charging current and charging voltage for the MF battery are different from those of general type batteries. The MF battery should be charged as explained in "CHARGING METHOD". If the battery is overcharged, the electrolyte level will drop considerably. Therefore, take special care when charging the battery.
-

⚠ WARNING

Battery electrolyte is dangerous; it contains sulfuric acid which is poisonous and highly caustic.

Always follow these preventive measures:

- Avoid bodily contact with electrolyte as it can cause severe burns or permanent eye injury.
- Wear protective eye gear when handling or working near batteries.

Antidote (EXTERNAL):

- SKIN - Wash with water.
- EYES - Flush with water for 15 minutes and get immediate medical attention.

Antidote (INTERNAL):

- Drink large quantities of water or milk followed with milk of magnesia, beaten egg or vegetable oil. Get immediate medical attention.

Batteries generate explosive hydrogen gas. Always follow these preventive measures:

- Charge batteries in a well-ventilated area.
- Keep batteries away from fire, sparks or open flames (e.g., welding equipment, lighted cigarettes, etc.)
- **DO NOT SMOKE** when charging or handling batteries.

KEEP BATTERIES AND ELECTROLYTE OUT OF REACH OF CHILDREN.

1.Remove:

- Seat
Refer to "SEAT, CARRIERS, FENDERS AND FUEL TANK".

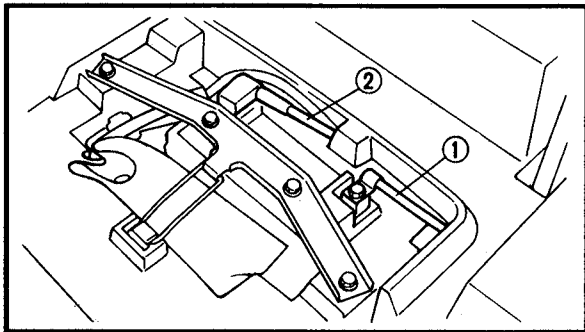

2.Disconnect:

- Battery leads

CAUTION:
First disconnect the negative lead ①, then disconnect the positive lead ②.

3.Remove:

- Battery holding bracket
- Battery

4.Check:

- Battery condition

Battery condition checking steps:

- Connect a digital voltmeter to the battery terminals.

Tester (+) lead → battery (+) terminal
Tester (-) lead → battery (-) terminal

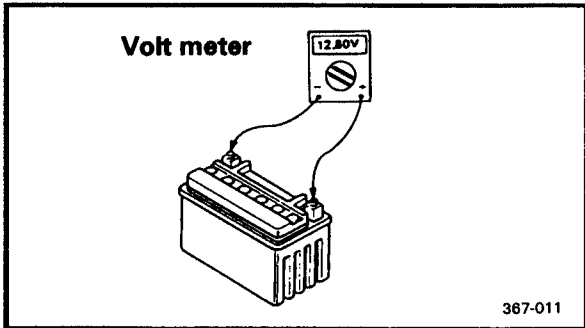

367-011

NOTE:
The charge state of an MF battery can be checked by measuring the open-circuit voltage (i.e. the voltage when the positive terminal is disconnected).

Open-circuit voltage	Charging time
12.8V or higher	No charging is necessary.

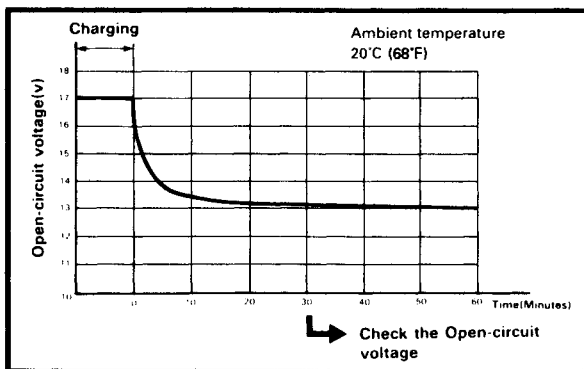
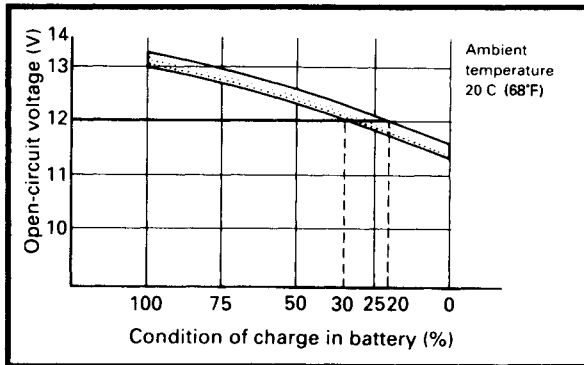
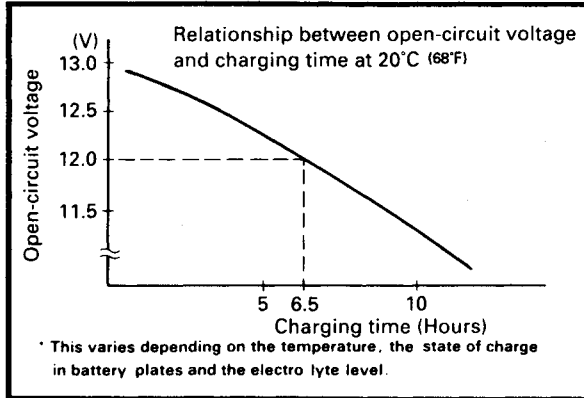

● Check the condition of the battery using the following charts.

Example:

- Open-circuit voltage = 12.0V
- Charging time = 6.5 hours
- Charge condition of the battery = 20 ~ 30%
- Charging method for MF batteries

CAUTION:

- If it is impossible to set the standard charging current, be careful not to over-charge.
- When charging the battery, be sure to remove it from the motorcycle. (If charging has to be done with the battery mounted on the motorcycle, be sure to disconnect the wire at the negative terminal.)
- Never remove the sealing caps of an MF battery.
- Make sure that the charging clips are in full contact with the terminal and that they are not shorted together. (A corroded clip on the charger may cause the battery to generate heat in the contact area. A weak clip spring may cause sparks.)
- Before removing the clips from the battery terminals, be sure to turn off the charger's power switch.
- The open-circuit voltage variation for the MF battery, after charging, is shown below. As shown in the figure, the open-circuit voltage stabilizes about 30 minutes after charging has been completed. Therefore, wait 30 minutes after charging is completed before measuring the open-circuit voltage.

Charging method using a variable-current (voltage) type charger

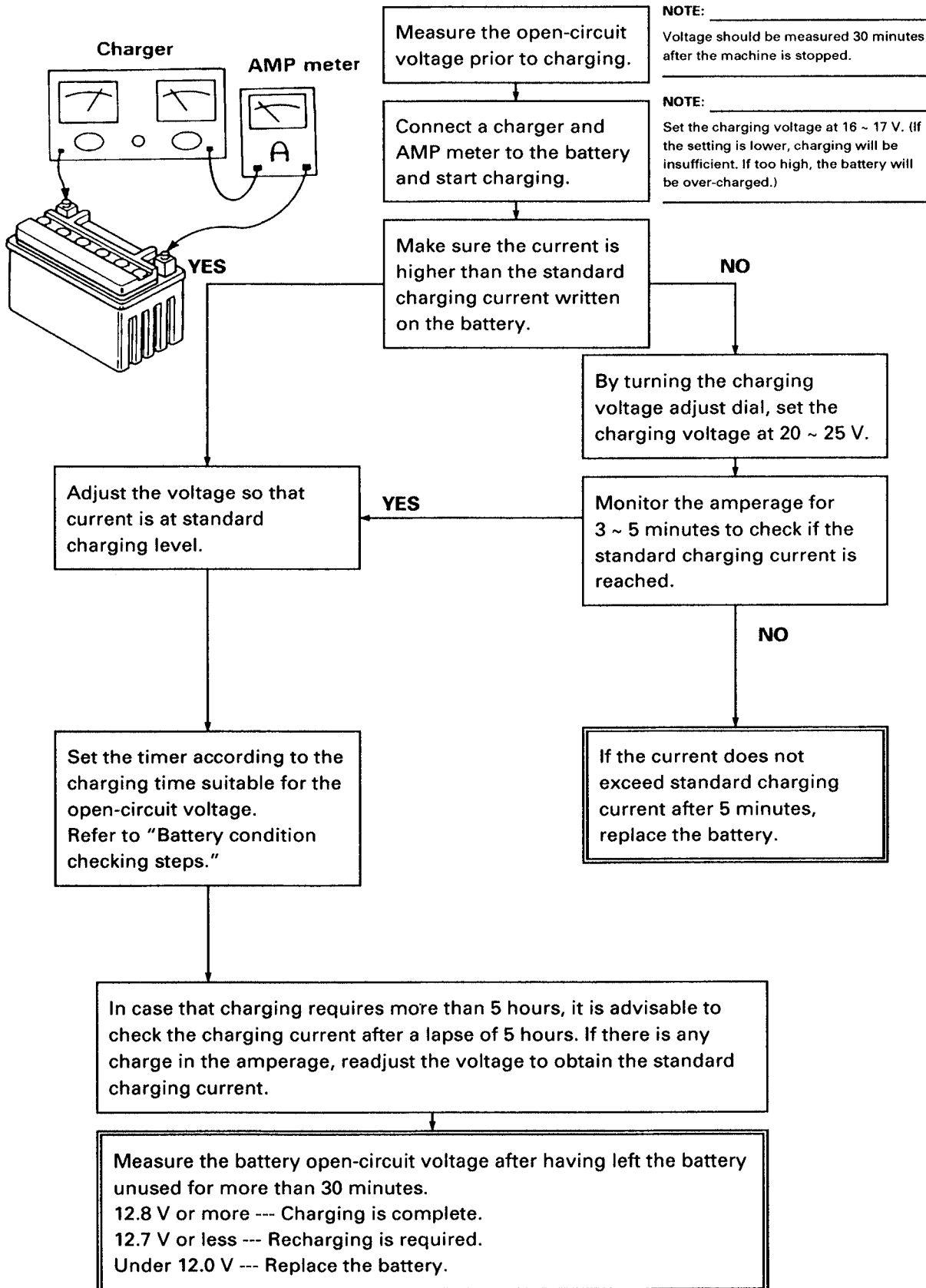

Charging method using a constant-voltage type charger

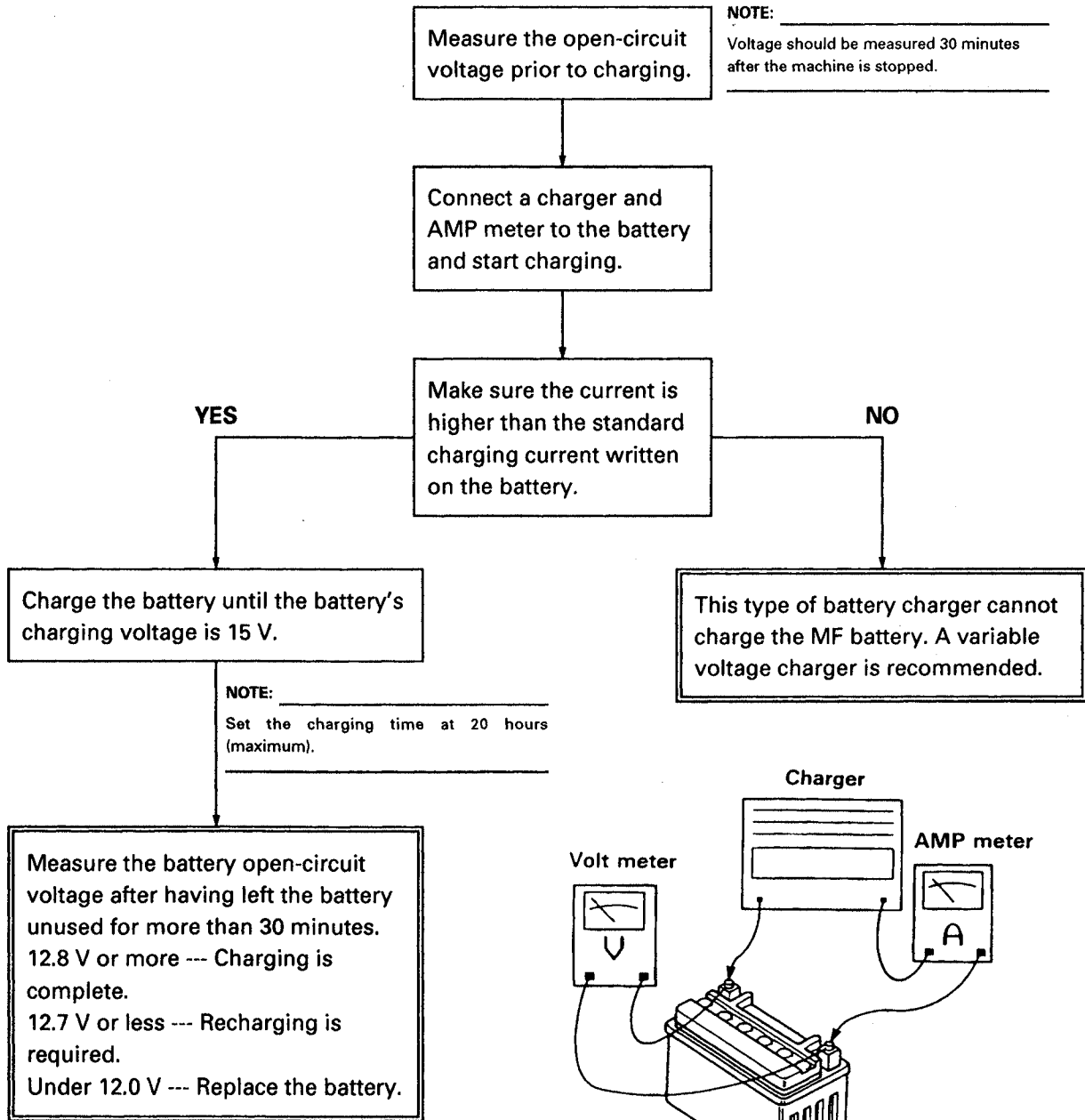

Charging method using a constant-current type charger
This type of battery charger cannot charge the MF battery.

5. Inspect:
- Battery terminals
Dirty → Clean with a wire brush.
Poor connection → Correct.

NOTE: _____
After cleaning the terminals, apply a light coat of grease.

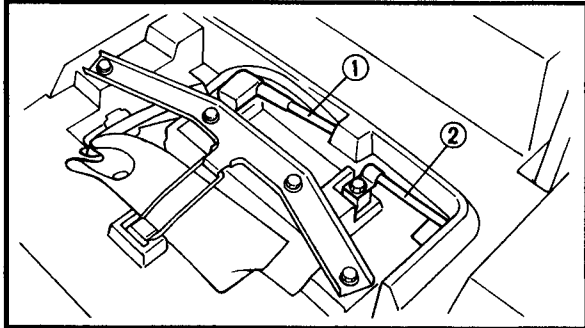

6. Install:
- Battery
 - Battery holding bracket
7. Connect:
- Battery leads

CAUTION: _____
First, connect the positive lead ①, then connect the negative lead ②.

8. Install:
- Seat
Refer to "SEAT, CARRIERS, FENDERS AND FUEL TANK".

FUSE INSPECTION

CAUTION: _____
Always turn off the main switch when checking or replacing a fuse. Otherwise, a short circuit may occur.

1. Remove:
- Seat
Refer to "SEAT, CARRIERS, FENDERS AND FUEL TANK".

2. Inspect:
- Fuses

Inspection steps:

- Connect the pocket tester to the fuse and check it for continuity.

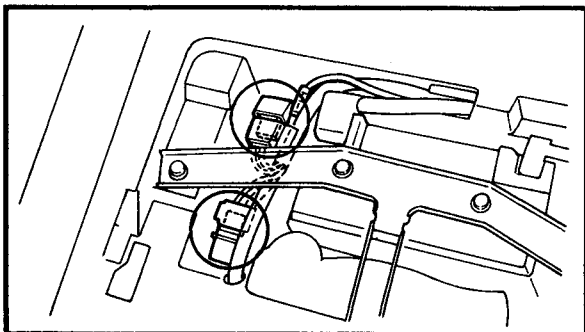

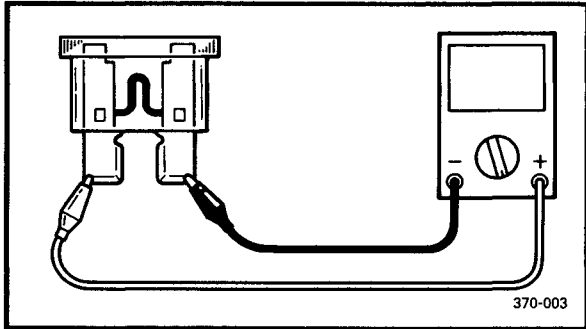

NOTE: _____
Set the tester to the "Ω × 1" position.

 **Pocket tester:**
P/N. YU-03112, 90890-03112

- If the tester indicates 0, replace the fuse.

3. Replace:

- Blown fuse

Replacement steps:

- Turn off the ignition.
- Install a new fuse of the proper amperage.
- Turn on switches to verify operation of the related electrical devices.
- If the fuse immediately blows again, check the electrical circuit.

Description	Current rating	Quantity
Main	30A	1
Terminal	10A	1
Reserve	30A	1
Reserve	10A	1

⚠ WARNING

Never use a fuse with a rating other than that specified. Never use other materials in place of a fuse. An improper fuse may cause extensive damage to the electrical system, a malfunction of the lighting and ignition systems and could possibly cause a fire.

4. Install:

- Seat
Refer to "SEAT, CARRIERS, FENDERS AND FUEL TANK".

HEADLIGHT BEAM ADJUSTMENT/ HEADLIGHT BULB REPLACEMENT

INSP
ADJ

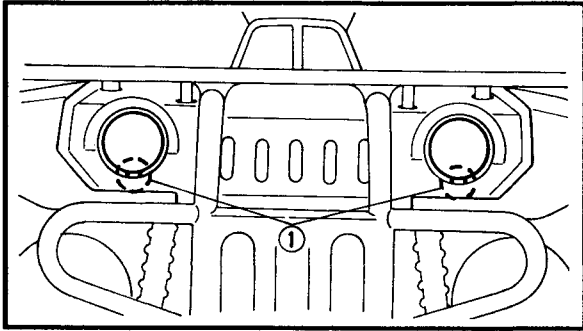

HEADLIGHT BEAM ADJUSTMENT

1.Adjust:

- Headlight beam (vertically)
Turn the adjuster ① in or out.

Turning in	Headlight beam raised.
Turning out	Headlight beam lowered.

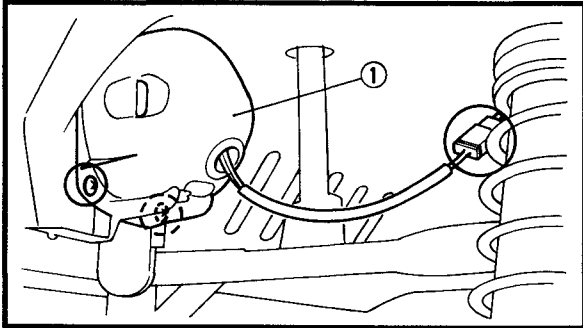

HEADLIGHT BULB REPLACEMENT

1.Disconnect:

- Headlight lead coupler
- 2.Remove:
- Headlight assembly ①

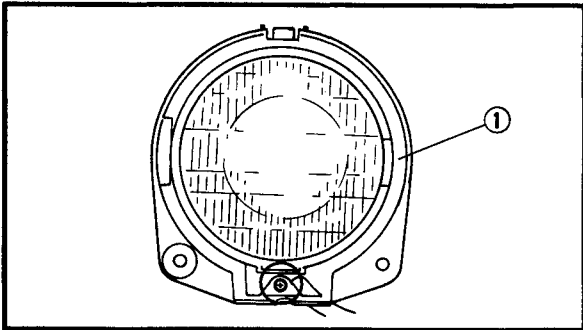

3.Remove:

- Headlight cover ①

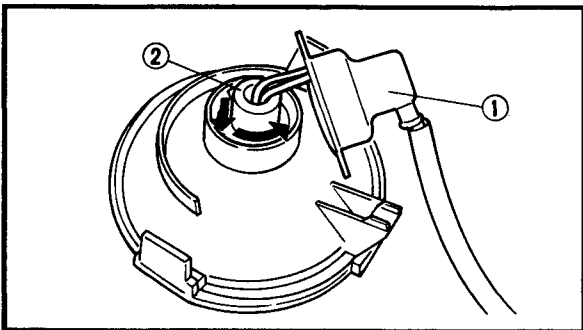

4.Remove:

- Cover ①
- Bulb holder ②
- Bulb

NOTE:

Turn the bulb holder counterclockwise and remove the defective bulb.

⚠ WARNING

Keep flammable products and your hands away from the bulb while it is on, since it will be hot. Do not touch the bulb until it cools down.



5.Install:

- Bulb (new)

Secure the new bulb with the headlight unit.

CAUTION:

Avoid touching the glass part of the bulb. Keep it free from oil; otherwise, the transparency of the glass, life of the bulb, and luminous flux will be adversely affected. If oil gets on the bulb, thoroughly clean it with a cloth moistened with alcohol or lacquer thinner.

6.Install:

- Bulb holder
- Cover
- Headlight cover
- Headlight assembly

7.Connect:

- Headlight lead couplers



ENGINE

ENGINE REMOVAL

AIR DUCTS, MUFFLER, EXHAUST PIPE, AND FOOTREST BOARD (right)

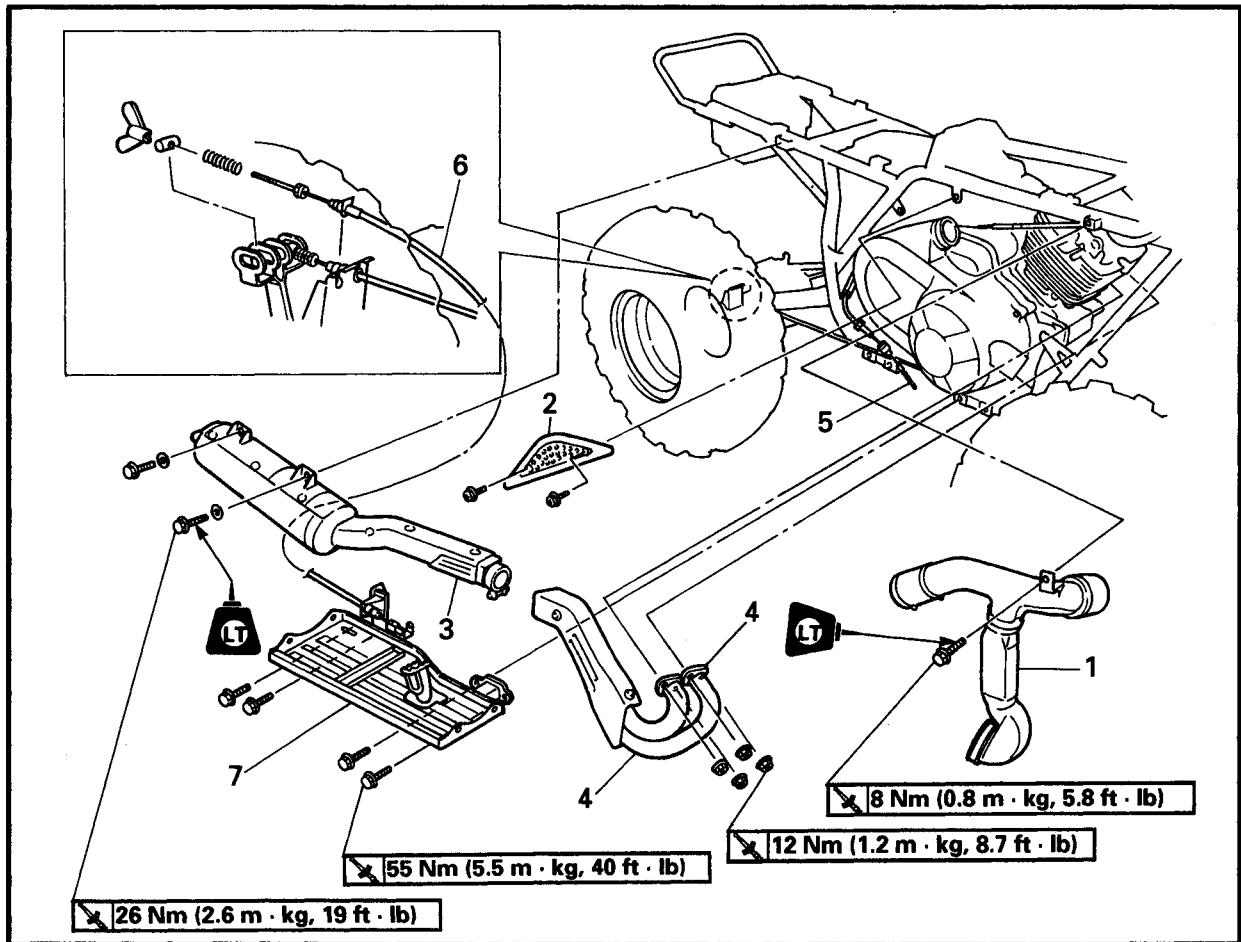

Order	Job name/Part name	Q'ty	Remarks
	Air duct, muffler, exhaust pipe and footrest board (right) removal		Remove the parts in the order below.
	Engine oil		Refer to "ENGINE OIL REPLACEMENT" in CHAPTER 3.
	Front and rear fender		Refer to "SEAT, CARRIERS, FENDERS AND FUEL TANK" in CHAPTER 3.
	Fuel tank / rubber cover		Refer to "SEAT, CARRIERS, FENDERS AND FUEL TANK" in CHAPTER 3.
	Carburetor assembly		Refer to "CARBURETOR" in CHAPTER 5.
1	Air duct assembly 2	1	
2	Guard	1	
3	Muffler	1	
4	Exhaust pipe / gasket	1/2	
5	Select control cable	1	
6	Brake cable	1	
7	Footrest board (right)	1	
			For installation, reverse the removal procedure.



SELECT LEVER UNIT AND FOOTREST BOARD (left)

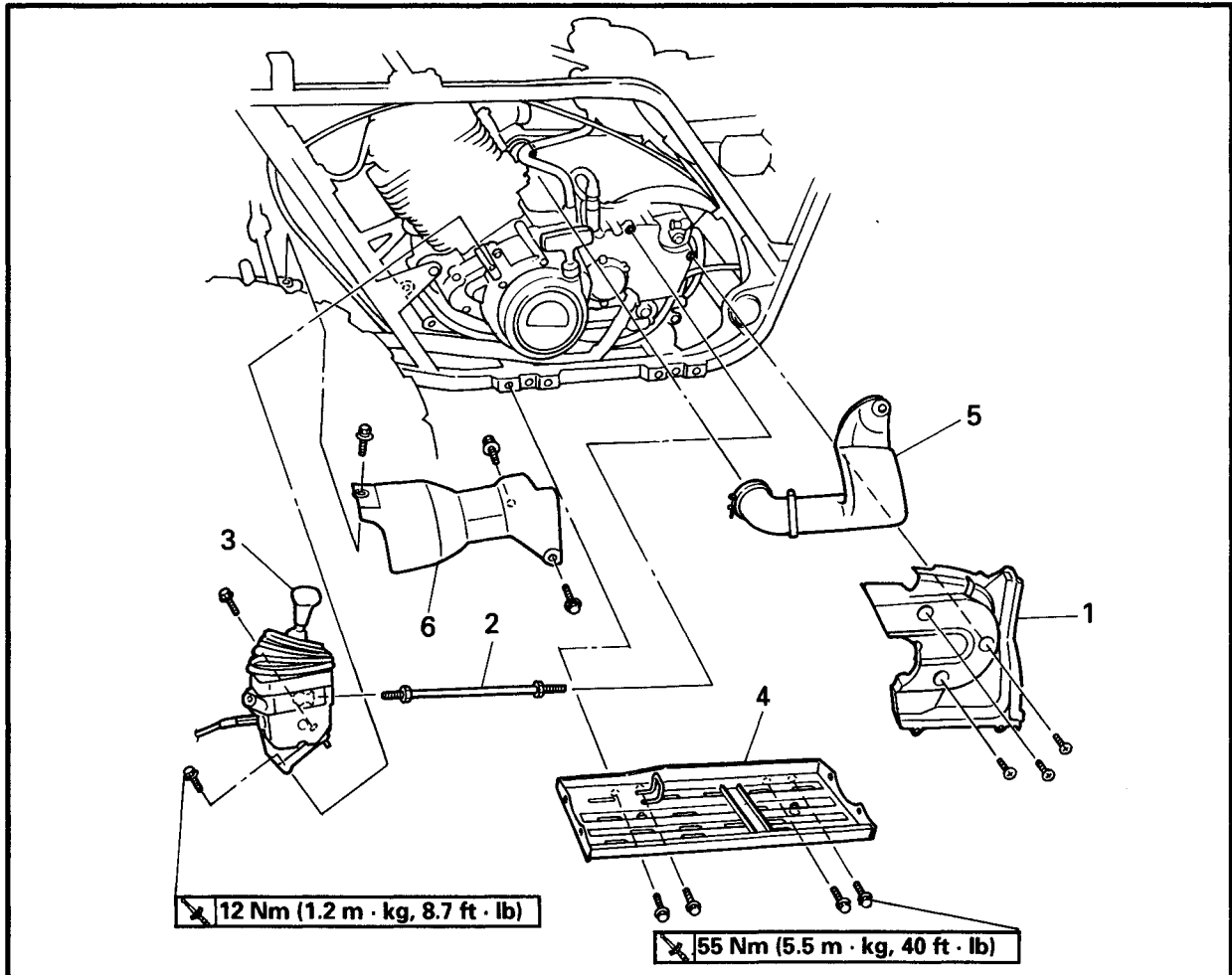

Order	Job name/Part name	Q'ty	Remarks
	Select lever unit and footrest board (left) removal		Remove the parts in the order below.
1	Cover	1	
2	Select lever shift rod	1	
3	Select lever unit	1	
4	Footrest board (left)	1	
5	Air duct assembly 1	1	
6	Front drive shaft protector	1	
			For installation, reverse the removal procedure.



HOSES AND LEADS

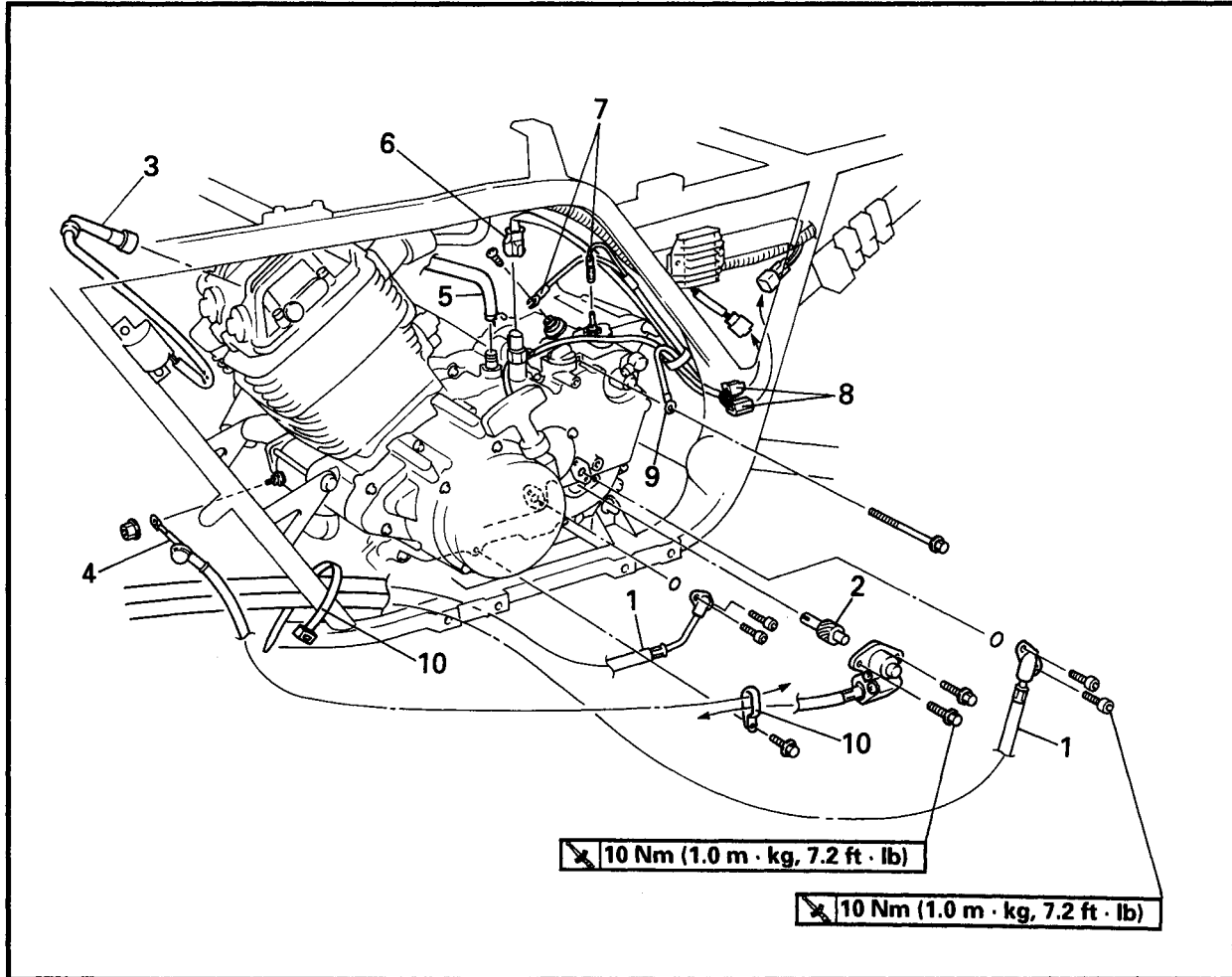

Order	Job name/Part name	Q'ty	Remarks
	Hoses and leads removal		Remove the parts in the order below.
1	Oil cooler hose	2	
2	Speedometer gear	1	
3	Spark plug lead	1	
4	Starter motor lead	1	
5	Crankcase breather hose	1	
6	Thermo unit coupler	1	
7	Neutral switch lead	2	
8	AC magneto lead coupler	2	
9	Ground lead	1	NOTE: _____ After disconnecting the ground lead, reinstall the bolt.
10	Metal clamp / plastic locking tie	1/1	For installation, reverse the removal procedure.



ENGINE MOUNTING BOLTS

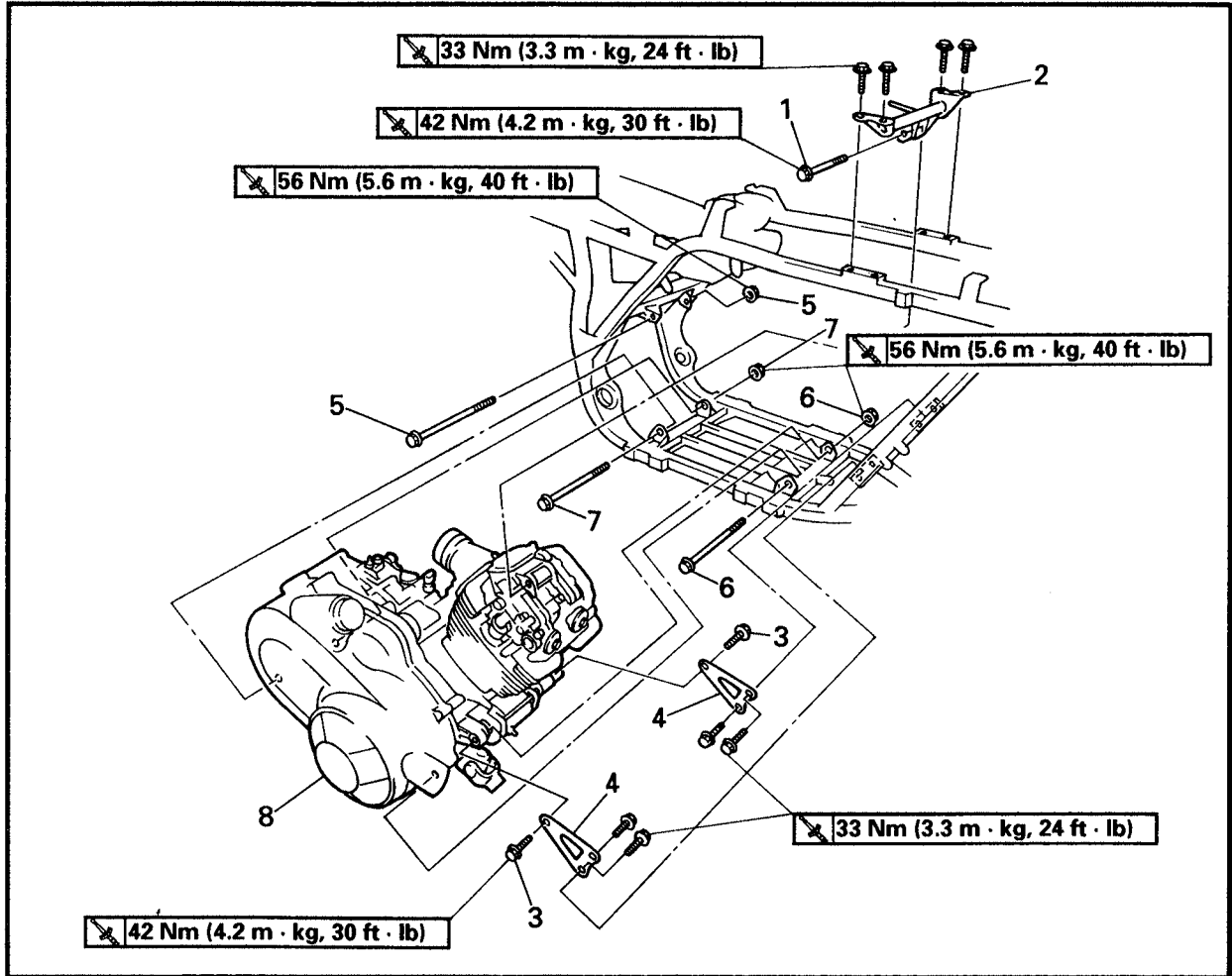

Order	Job name/Part name	Q'ty	Remarks	
	Engine mounting bolt removal		Remove the parts in the order below.	
	Rear wheels		Refer to "FRONT AND REAR WHEELS" in CHAPTER 7.	
	Swingarm		Refer to "REAR SHOCK ABSORBER AND SWINGARM" in CHAPTER 7.	
1	Engine mounting bolt (front-upper)	1	<div style="border: 1px solid black; padding: 5px;"> <p>CAUTION:</p> <p>Install all of the bolts/nuts and then tighten them to full torque specifications.</p> </div>	
2	Engine bracket (front-upper)	2		
3	Engine mounting bolt (front-middle)	1		
4	Engine bracket (front-middle)	2		
5	Engine mounting bolt (rear-upper)/nut	1/1		L=140 mm
6	Engine mounting bolt (front-lower)/nut	1/1		L=190 mm
7	Engine mounting bolt (rear-lower)/nut	1/1		L=190 mm

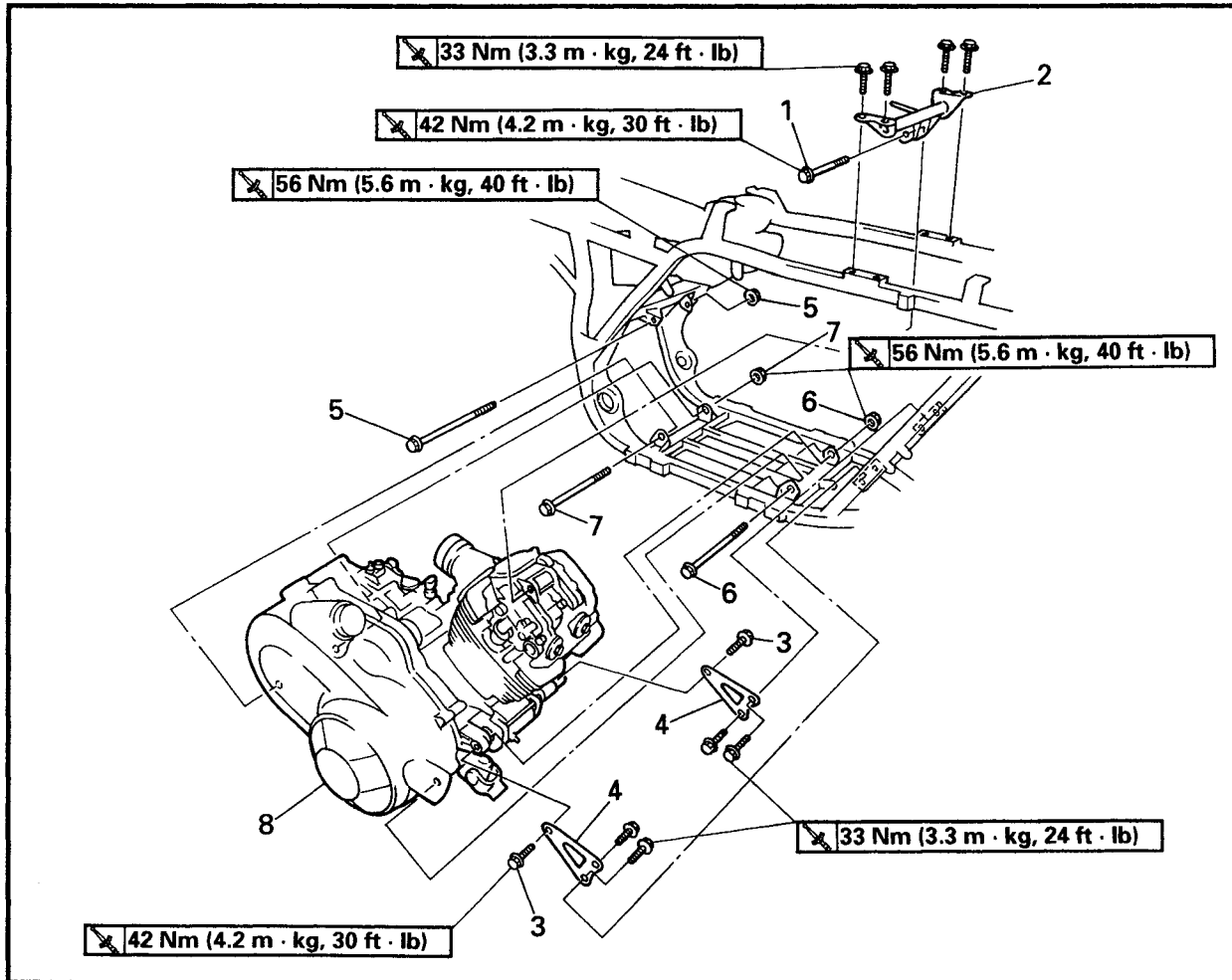

Order	Job name/Part name	Q'ty	Remarks
8	Engine assembly	1	<p>NOTE: _____ Remove the engine assembly from the right side of the machine.</p> <p>_____</p> <p>For installation, reverse the removal procedure.</p>



CYLINDER HEAD COVER

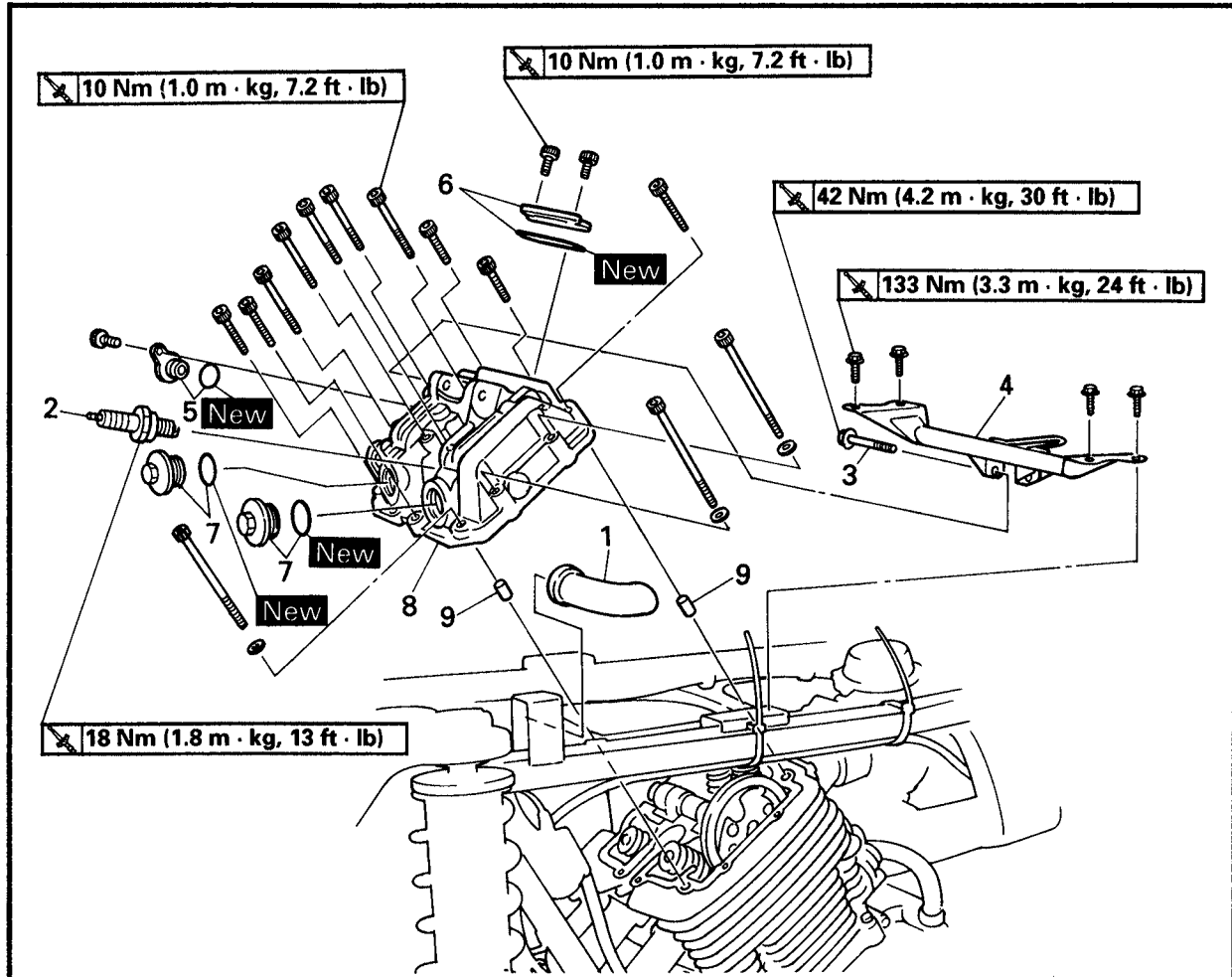

Order	Job name/Part name	Q'ty	Remarks
	Cylinder head cover removal		Remove the parts in the order below.
	Front fender		Refer to "SEAT, CARRIERS, FENDERS AND FUEL TANK" in CHAPTER 3.
	Fuel tank / rubber cover		
	Recoil starter		
	Timing plug		Refer to "VALVE CLEARANCE ADJUSTMENT" in CHAPTER 3.
1	Air duct	1	
2	Spark plug	1	
3	Engine mounting bolt (upper)	1	
4	Engine bracket (upper)	1	
5	Camshaft end cover / O-ring	1/1	
6	Tappet cover (intake) / O-ring	1/1	
7	Tappet cover (exhaust) / O-ring	2/2	
8	Cylinder head cover	1	Refer to "CYLINDER HEAD COVER REMOVAL / INSTALLATION".
9	Dowel pin	2	
			For installation, reverse the removal procedure.

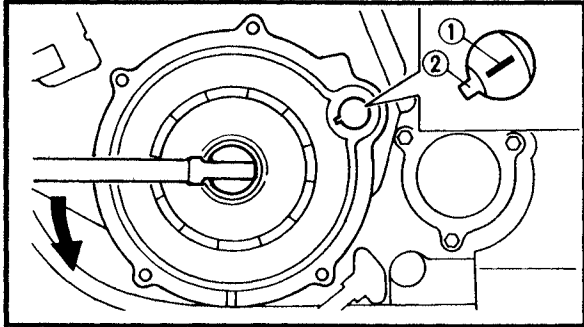

CYLINDER HEAD COVER REMOVAL

1.Align:

- "I" mark
(with stationary pointer)

Checking steps:

- Turn the crankshaft counterclockwise with a wrench.
- Align the "I" mark ① on the rotor with the stationary pointer ② on the crankcase cover. When the "I" mark is aligned with the stationary pointer, the piston is at Top Dead Center (T.D.C.).

NOTE:

- When the piston is at top dead center (TDC) on the compression stroke, there should be clearance between the valve stem tips and their respective rocker arm adjusting screws.
- If there is no clearance, rotate the crankshaft counterclockwise one turn.

2.Remove:

- Cylinder head cover

NOTE:

Working in a crisscross pattern, loosen each bolt 1/4 of a turn. After all the bolts are loosened, remove them.

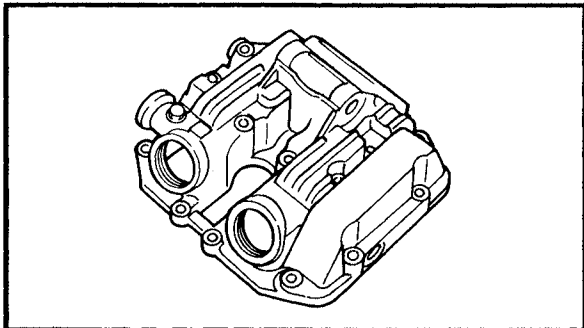

CYLINDER HEAD COVER INSPECTION

1.Inspect:

- Cylinder head cover
Cracks / damage → Replace.

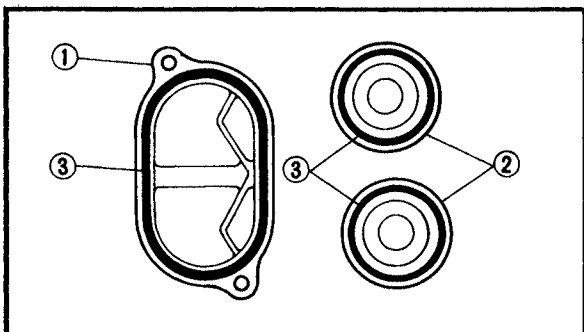

TAPPET COVER INSPECTION

1.Inspect:

- Tappet cover (intake) ①
- Tappet cover (exhaust) ②
- O-ring ③
Cracks / damage → Replace.

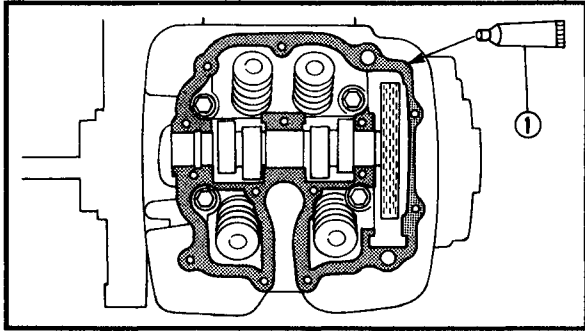

CYLINDER HEAD COVER INSTALLATION

1. Apply:

- Sealant (Quick Gasket®) ①
(to the mating surfaces of the cylinder head and cylinder head cover)



Sealant (Quick Gasket®) ①
P/N. ACC-11001-05-01
Yamaha bond No. 1215®:
P/N. 90890-85505

2. Install:

- Cylinder head cover
- Bolts  **10 Nm (1.0 m · kg, 7.2 ft · lb)**

NOTE:

Tighten the cylinder head cover bolts stages, using a cirsscross pattern.



ROCKER ARMS

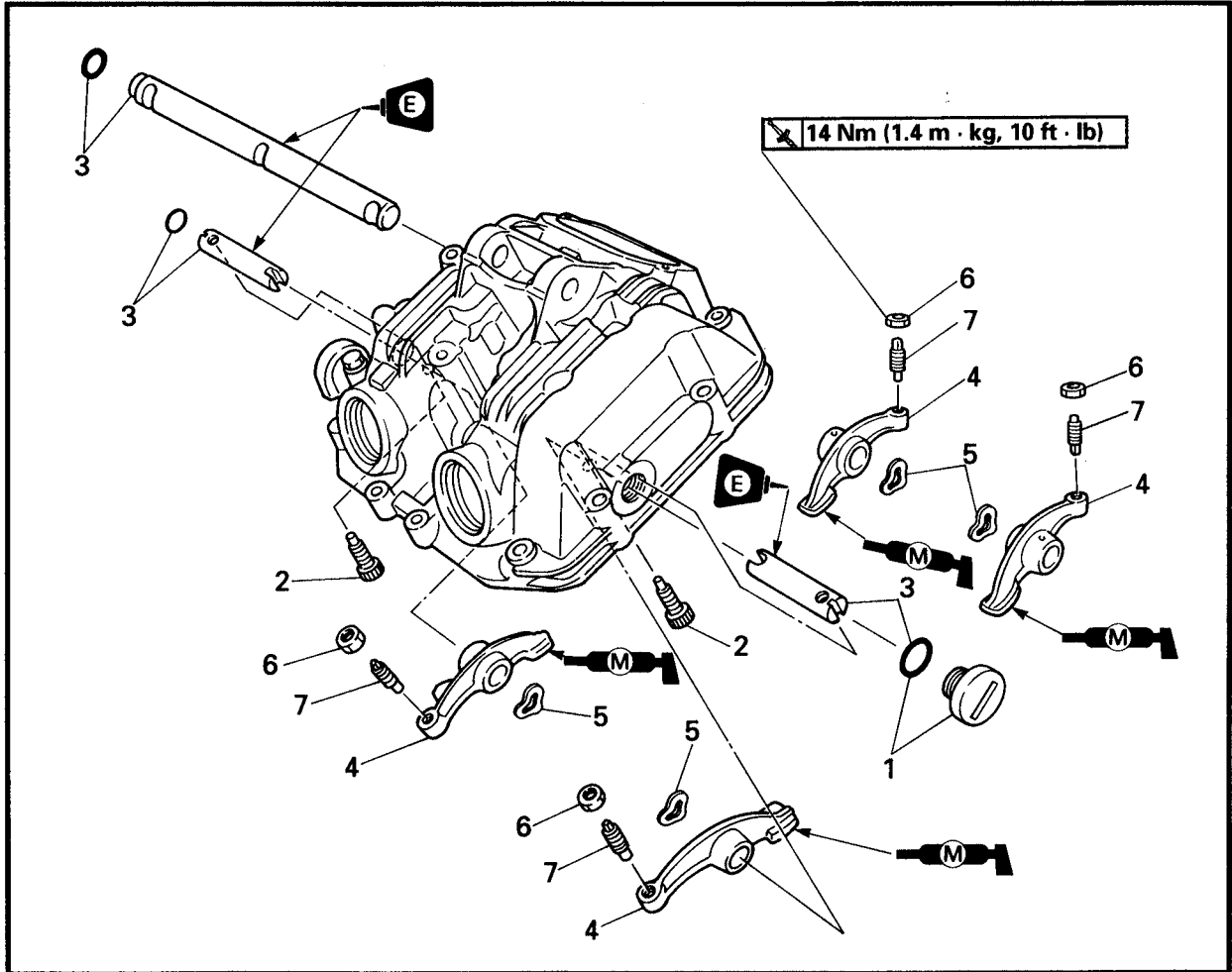

Order	Job name/Part name	Q'ty	Remarks
	Rocker arm removal		Remove the parts in the order below. Refer to "CYLINDER HEAD COVER".
1	Cylinder head cover		
1	Plug / O-ring	1/1	
2	Bolt	2	
3	Rocker arm shaft / O-ring	3/2	Refer to "ROCKER ARM REMOVAL / INSTALLATION".
4	Rocker arm	4	
5	Spring	4	
6	Locknut	4	
7	Valve adjuster	4	
			For installation, reverse the removal procedure.

ROCKER ARMS

ENG

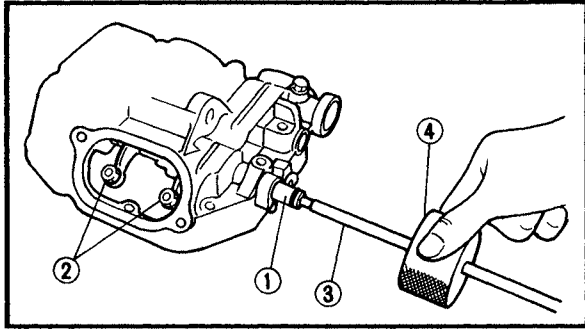

ROCKER ARM REMOVAL

1.Remove:

- Rocker arm shafts (intake and exhaust) ①
- Rocker arms ②

NOTE:

Use a slide hammer ③ to remove the rocker arm shafts.



Slide hammer set:

P/N. YU-01083-A

Slide hammer bolt (M6):

P/N. 90890-01083

Weight:

P/N. 90890-01084

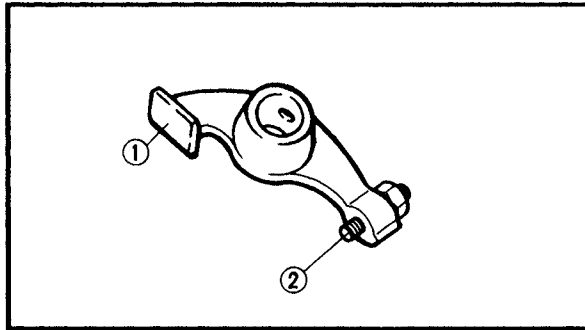

ROCKER ARM AND CAMSHAFT INSPECTION

1.Inspect:

- Camshaft bushings
Damage/wear → Replace.

2.Inspect:

- Camshaft lobes ①
- Valve adjusters ②
Blue discoloration/pitting/scratches → Replace.

3.Inspect:

- Rocker arms
- Rocker arm shafts
Damage/wear → Replace.

Inspection steps:

- Inspect the two contact areas on the rocker arms for signs of abnormal wear.

- 1) Rocker arm shaft hole.
- 2) Camshaft lobe contact surface.

Excessive wear → Replace.

- Inspect the surface of the rocker arm shafts.
Blue discoloration/pitting/scratches → Replace/check lubrication.

- Measure the inside diameter ③ of the rocker arm holes.

Out of specification → Replace.

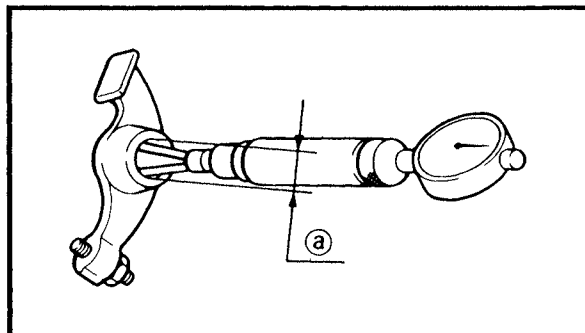

Rocker arm inside diameter:

12.000 ~ 12.018 mm

(0.4724 ~ 0.4731 in)

ROCKER ARMS

ENG

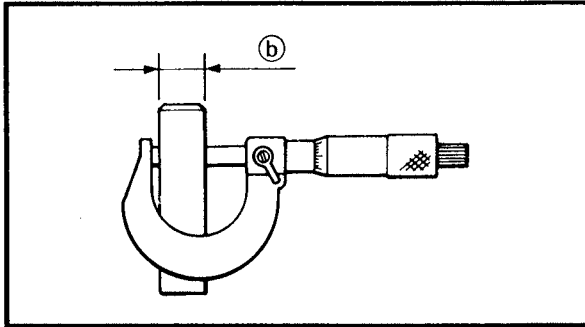

- Measure the outside diameter (b) of the rocker arm shafts.
Out of specification → Replace.



Rocker arm outside diameter:
11.985 ~ 11.991 mm
(0.4719 ~ 0.4721 in)

- Calculate the clearance by subtracting the rocker arm shaft outside diameter from the rocker arm inside diameter.
Clearance greater than 0.08 mm (0.003 in)
→ Replace the defective part(s).



Rocker arm to shaft standard clearance:
0.009 ~ 0.033 mm
(0.0004 ~ 0.0013 in)

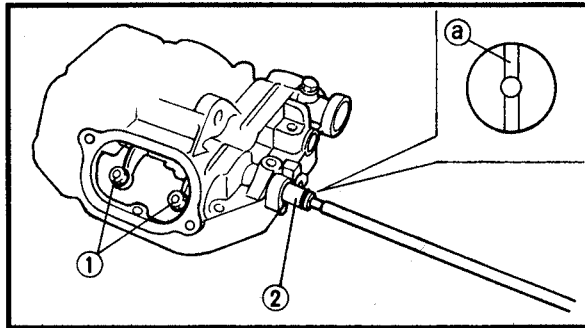

ROCKER ARM INSTALLATION

1. Apply:
 - Engine oil
(onto the rocker arm shafts)
2. Install:
 - Rocker arms ①
 - Rocker arm shafts (intake and exhaust) ②

NOTE:

- The thread hole (a) of the rocker arm shafts must face to the outside.
- After installation, make sure that the thread hole (a) of the rocker arm shaft is positioned correctly, as shown in the illustration.

CAMSHAFT AND CYLINDER HEAD

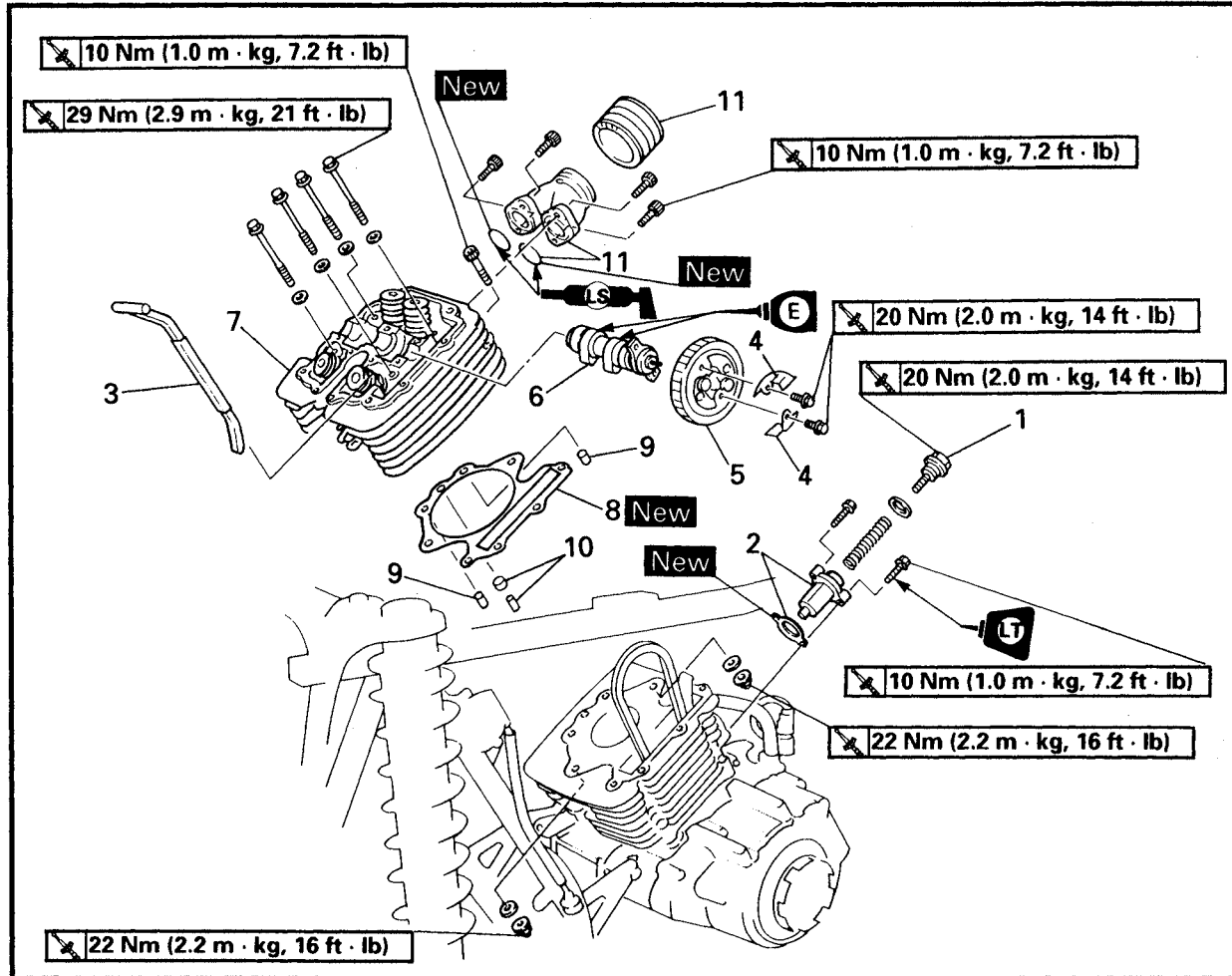

Order	Job name/Part name	Q'ty	Remarks
	Camshaft and cylinder head removal		Remove the parts in the order below.
	Fuel tank / rubber cover		Refer to "SEAT, CARRIERS, FENDERS AND FUEL TANK" in CHAPTER 3.
	Rear fender		
	Air duct assembly 2		Refer to "ENGINE REMOVAL".
	Exhaust pipe / muffler		
	Carburetor assembly		Refer to "CARBURETOR" in CHAPTER 5. Refer to "CYLINDER HEAD COVER".
	Cylinder head cover		
1	Timing chain tensioner cap bolt	1	Refer to "CAMSHAFT AND CYLINDER HEAD REMOVAL / INSTALLATION".
2	Timing chain tensioner / gasket	1/1	
3	Timing chain guide (exhaust)	1	
4	Decompressor cam guide plate	2	
5	Camshaft sprocket	1	
6	Camshaft	1	
7	Cylinder head	1	

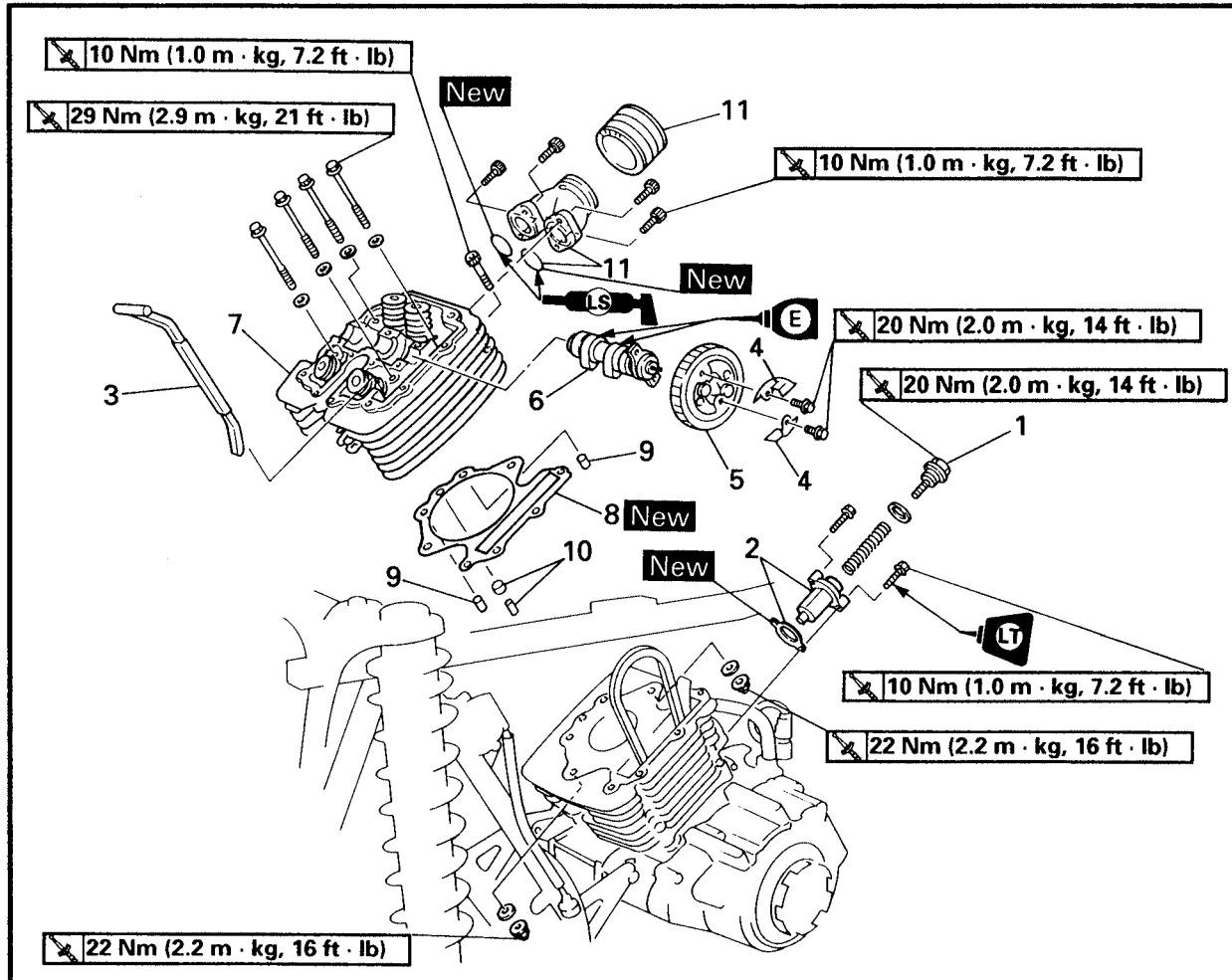

Order	Job name/Part name	Q'ty	Remarks
8	Cylinder head gasket	1	For installation, reverse the removal procedure.
9	Dowel pin	2	
10	Dowel pin / gasket	1/1	
11	Intake manifold / O-ring	1/2	

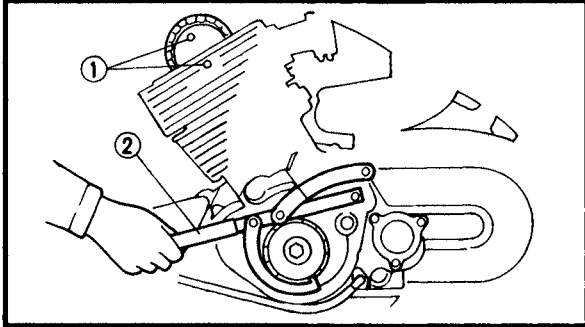

CAMSHAFT AND CYLINDER HEAD REMOVAL

1. Loosen:

- Camshaft sprocket bolt ①

NOTE:

Use the rotor holder ② to hold the starter pulley.



Rotor holder:

P/N. YU-01235, 90890-01235

2. Loosen:

- Timing chain tensioner cap bolt

3. Remove:

- Timing chain tensioner
- Timing chain guide (exhaust)
- Decompressor guide plate
- Camshaft sprocket

NOTE:

- Fasten a safety wire to the timing chain to prevent it from falling into the crankcase.
- When removing the camshaft sprocket, it is not necessary to separate the timing chain.

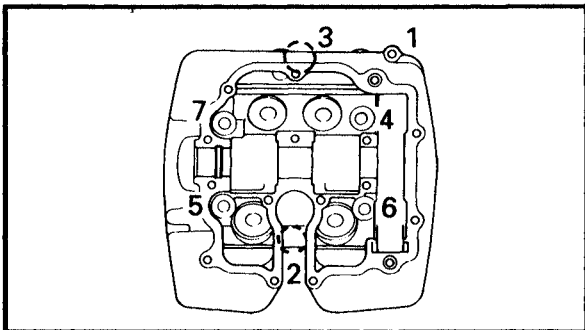

4. Remove:

- Cylinder head

NOTE:

- Loosen the bolts and nuts in the proper sequence.
- Follow the numerical order shown in the illustration. Loosen each bolt 1/4 of a turn at a time until all of the bolts are loose.

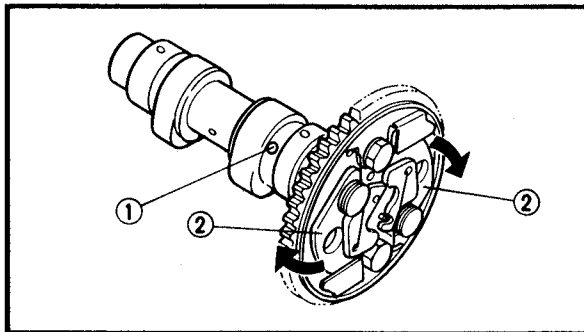
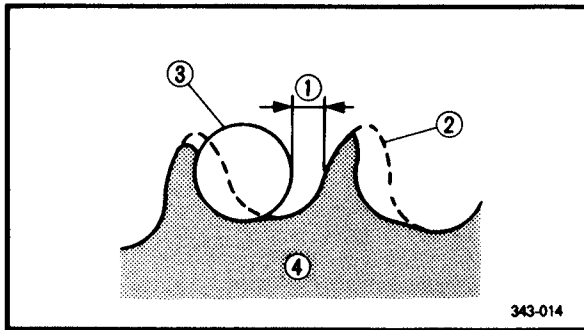
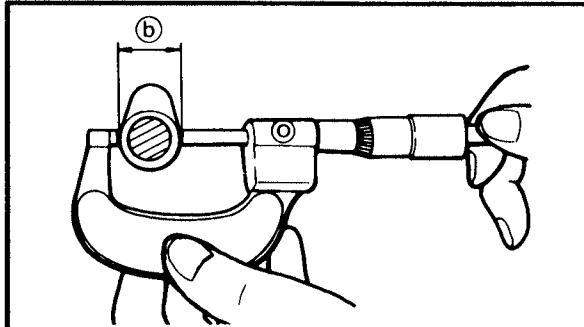
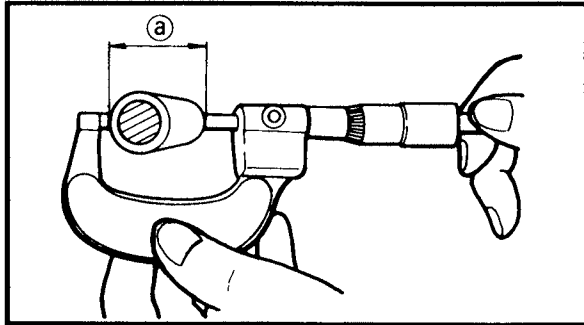

CAMSHAFT INSPECTION

1. Inspect:
 - Cam lobes
 - Pitting/scratches/blue discoloration → Replace.
2. Measure:
 - Cam lobes length (a) and (b).
 - Out of specification → Replace.



Camshaft lobe limit:

Intake

- (a) 36.37 mm (1.433 in)
- (b) 29.96 mm (1.180 in)

Exhaust:

- (a) 36.52 mm (1.438 in)
- (b) 30.01 mm (1.181 in)

CAMSHAFT SPROCKET INSPECTION

1. Inspect:
 - Camshaft sprocket
 - Wear/damage → Replace the camshaft sprocket and timing chain as a set.
- ① 1/4 of a tooth
 - ② Correct
 - ③ Roller
 - ④ Sprocket

DECOMPRESSION SYSTEM INSPECTION

1. Check:
 - Decompression system

Checking steps:

Check while the camshaft sprocket is installed on the camshaft.

- Check that the decompressor lever pin ① projects from the camshaft.
- Check that the decompressor cam ② moves smoothly.



TIMING CHAIN GUIDE INSPECTION

1. Inspect:
- Exhaust side timing chain guide
- Wear / damage → Replace.

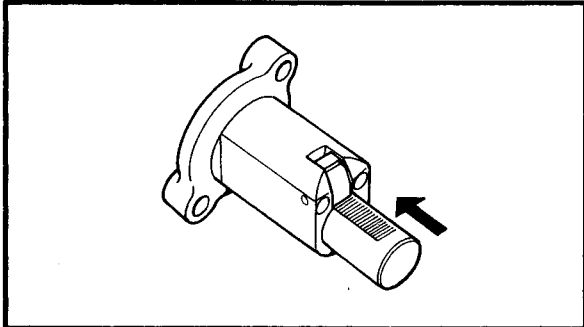

TIMING CHAIN TENSIONER INSPECTION

1. Check:
- One-way cam operation (tensioner)
- Unsmooth operation → Replace.

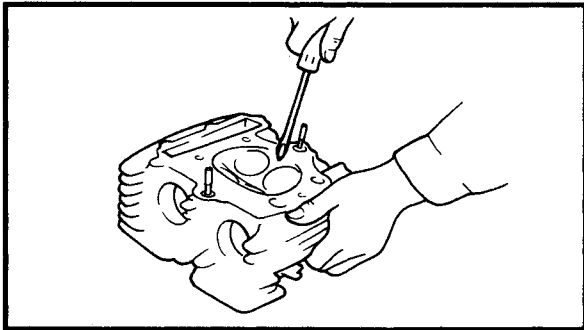

CYLINDER HEAD INSPECTION

1. Eliminate:
- Carbon deposits (from the combustion chambers)
- Use a rounded scraper.

NOTE:

Do not use a sharp instrument to avoid damaging or scratching:

- Spark plug threads
- Valve seats

2. Inspect:

- Cylinder heads
- Scratches/damage → Replace.

3. Measure:

- Cylinder head warpage
- Out of specification → Resurface.



Cylinder head warpage:
Less than 0.03 mm (0.002 in)

Warpage measurement and resurfacement steps:

- Place a straightedge and a feeler gauge across the cylinder head.
- Use a feeler gauge to measure the warpage.
- If the warpage is out of specification, resurface the cylinder head.

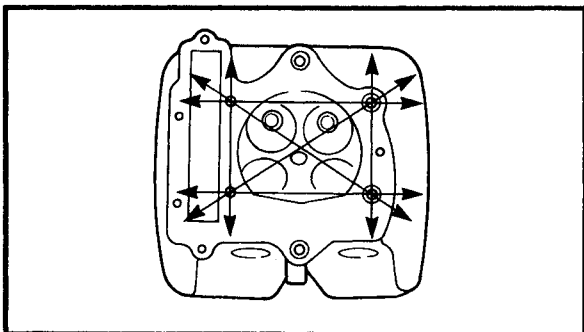



- Place a 400 ~ 600 grit wet sandpaper on the surface plate, and resurface the head using a figure-eight sanding pattern.

NOTE: _____
 To ensure an even surface rotate the cylinder head several times.

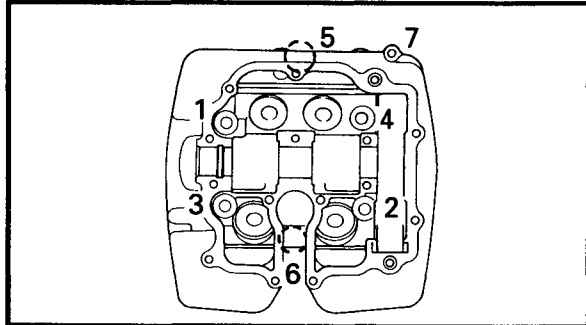

CAMSHAFT AND CYLINDER HEAD INSTALLATION

1.Install:

- Cylinder head
- Bolts (M8 : 1~4)

29 Nm (2.9 m · kg, 21 ft · lb)

- Nuts (M8 : 5, 6)

22 Nm (2.2 m · kg, 16 ft · lb)

- Bolt (M6 : 7)

10 Nm (1.0 m · kg, 7.2 ft · lb)

NOTE: _____
 ● Tighten the bolts and nuts in the proper sequence.
 ● Follow the numerical order shown in the illustration. Tighten the bolts and nuts in two stages.

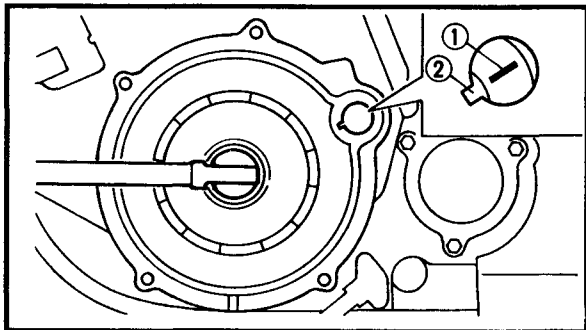

2.Install:

- Camshaft
- Camshaft sprocket

Installation steps:

- Turn the crankshaft counterclockwise with a wrench.
- Align the "I" mark ① on the rotor with the stationary pointer ② on the crankcase cover. When the "I" mark is aligned with the stationary pointer, the piston is at Top Dead Center (T.D.C.).

CAUTION _____
Do not turn the crankshaft during the camshaft installation.

CAMSHAFT AND CYLINDER HEAD

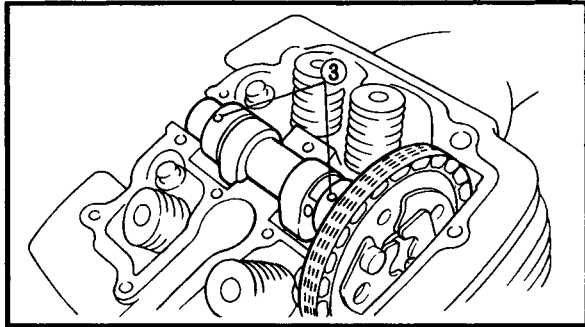

- Temporarily install the camshaft sprocket on the camshaft. (Do not install the bolts.) Then, install the timing chain on the camshaft sprocket.

NOTE: _____
 Make sure the small holes ③ on the camshaft face upward.

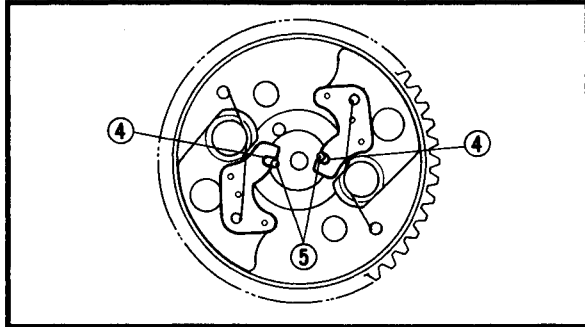

- Align the notches ④ on the decompressor cam with the projections ⑤ on the decompressor spring lever, then install the camshaft sprocket on the camshaft.

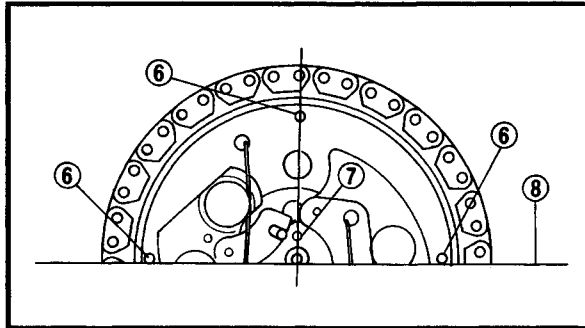

NOTE: _____
 Check that each part is positioned as shown in the illustration.

- ⑥ Small holes on camshaft sprocket
- ⑦ Punch mark on decompressor spring lever
- ⑧ Top front of cylinder head

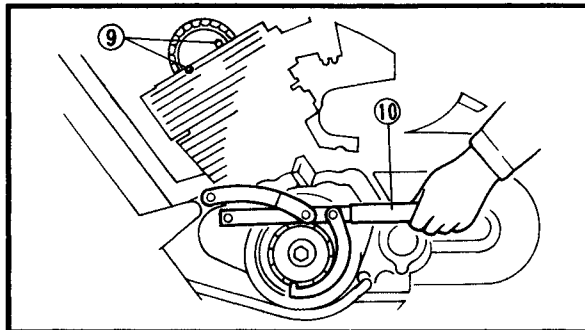

- Tighten the camshaft sprocket bolts ⑨.

NOTE: _____
 Use the rotor holder ⑩ to hold the starter pulley.

 **Rotor holder:**
 P/N. YU-01235, 90890-01235

 **Camshaft sprocket bolt:**
 20 Nm (2.0 m · kg, 14 ft · lb)

- Remove the retaining wire.
- *****

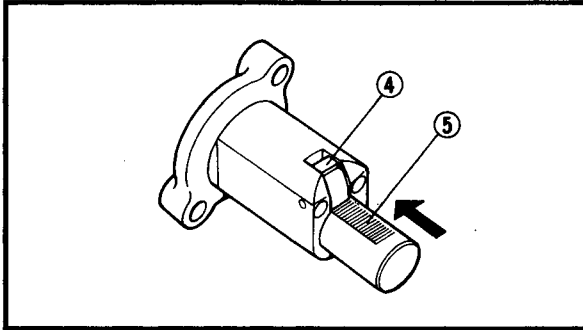
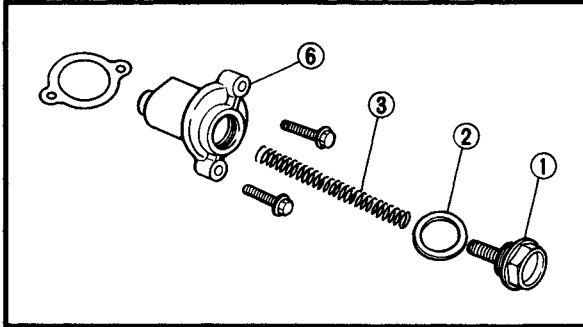

3. Install:

- Timing chain tensioner

Installation steps:

- Remove the tensioner cap bolt ①, washer ② and spring ③.
- Release the timing chain tensioner one-way cam ④ and push the tensioner rod ⑤ all the way in.
- Install the tensioner ⑥ with a new gasket into the cylinder.



Bolts (timing chain tensioner):
10 Nm (1.0 m · kg, 7.2 ft · lb)

⚠ WARNING

Always use a new gasket.

- Install the spring, washer and cap bolt.



Cap bolt (timing chain tensioner):
20 Nm (2.0 m · kg, 14 ft · lb)

4. Check:

- Small holes on camshaft sprocket
- Rotor "I" mark
Out of alignment → Adjust.

VALVES AND VALVE SPRINGS

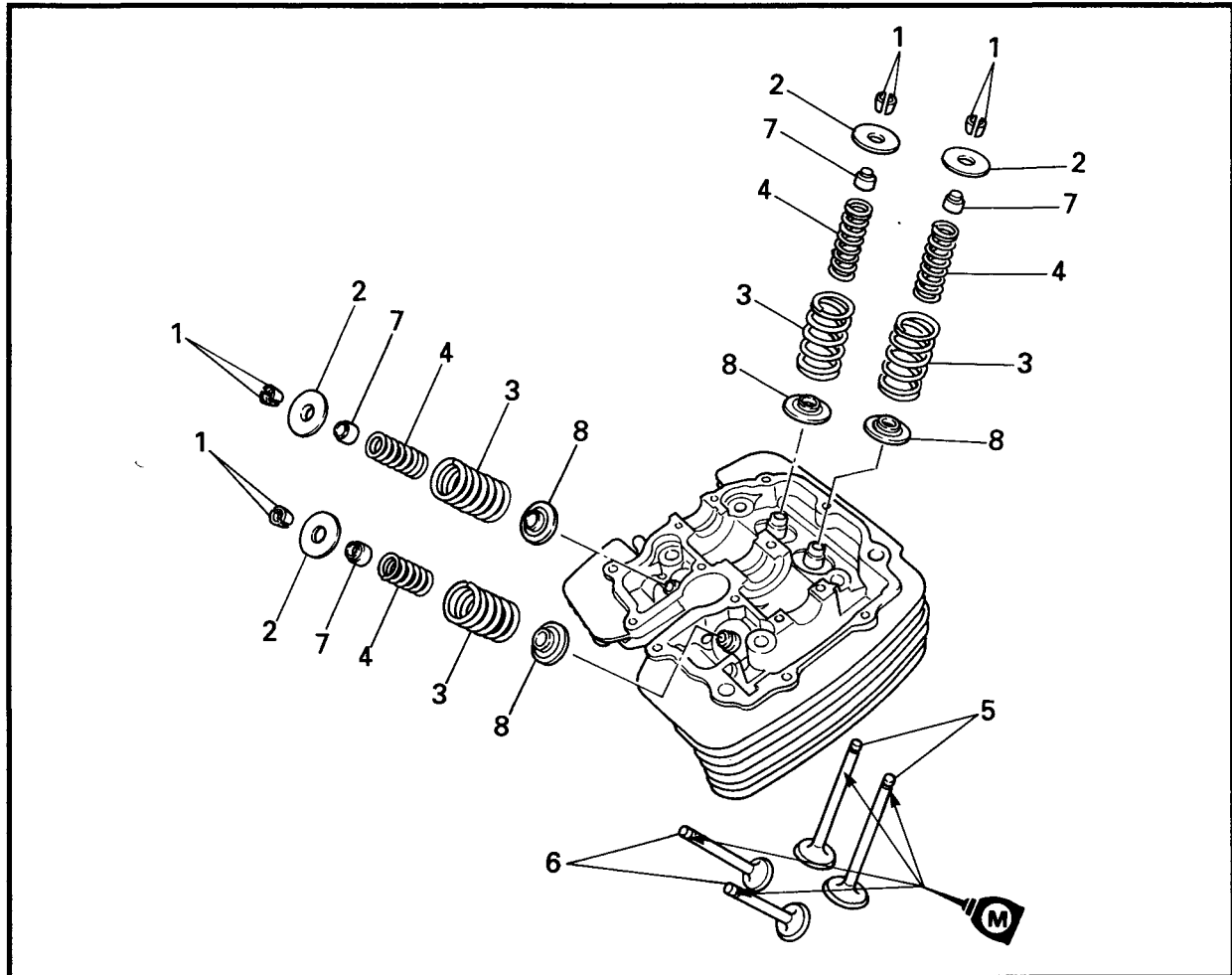

Order	Job name/Part name	Q'ty	Remarks
	Valve and valve spring removal		
	Cylinder head		Remove the parts in the order below. Refer to "CYLINDER HEAD".
1	Valve cotter	8	Refer to "VALVE AND VALVE SPRING REMOVAL / INSTALLATION".
2	Valve spring retainer	4	
3	Valve spring (outer)	4	
4	Valve spring (inner)	4	
5	Valve (inner)	2	
6	Valve (exhaust)	2	
7	Valve stem seal	4	
8	Valve spring seat	4	
			For installation, reverse the removal procedure.

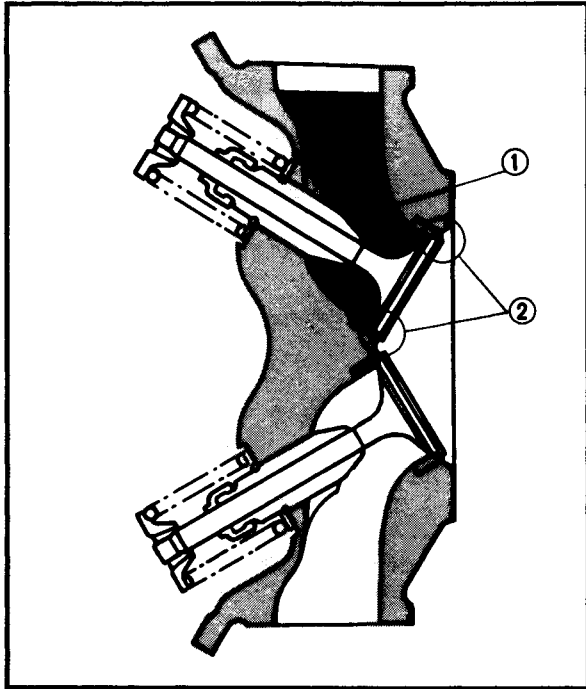

VALVE AND VALVE SPRING REMOVAL

1. Check:

- Valve sealing
Leakage at the valve seat → Inspect the valve face, valve seat and valve seat width.
Refer to "VALVE AND VALVE SPRING INSPECTION".

Checking steps:

- Pour a clean solvent ① into the intake and exhaust ports.
- Check that the valve seals properly.
There should be no leakage at the valve seat ②.

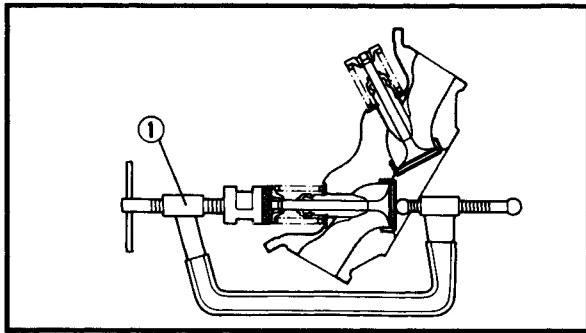

2. Remove:

- Valve cotters

NOTE:

Attach a valve spring compressor ① between the valve spring retainer and the cylinder head to remove the valve cotters.



Valve spring compressor:
P/N. YM-04019, 90890-04019

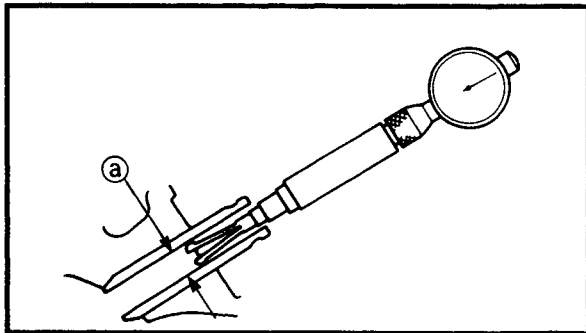

VALVE AND VALVE SPRING INSPECTION

1. Measure:

- Stem-to-guide clearance

$$\text{Stem-to-guide clearance} = \text{valve guide inside diameter } \textcircled{a} - \text{valve stem diameter } \textcircled{b}$$

Out of specification → Replace the valve guide.

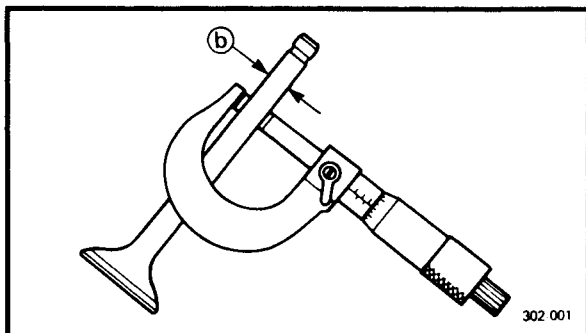

Clearance (stem to guide):

Intake:

0.010 ~ 0.037 mm
(0.0004 ~ 0.0015 in)
<Limit>: 0.08 mm (0.003 in)

Exhaust:

0.030 ~ 0.057 mm
(0.0012 ~ 0.0022 in)
<Limit>: 0.10 mm (0.004 in)

302 001

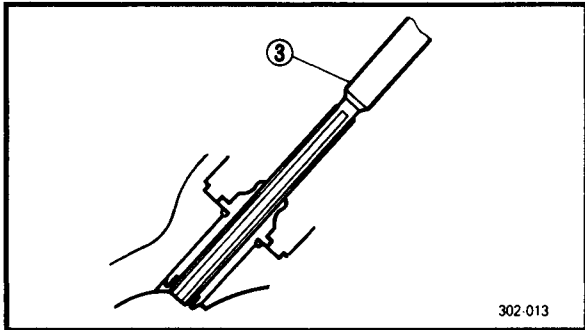
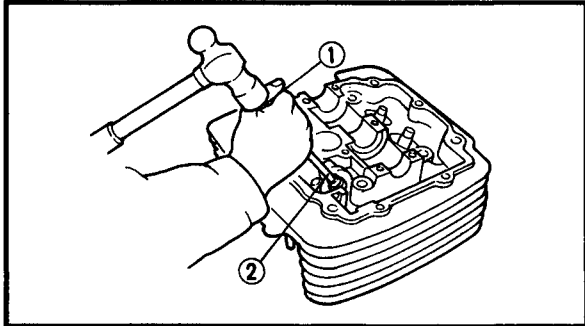
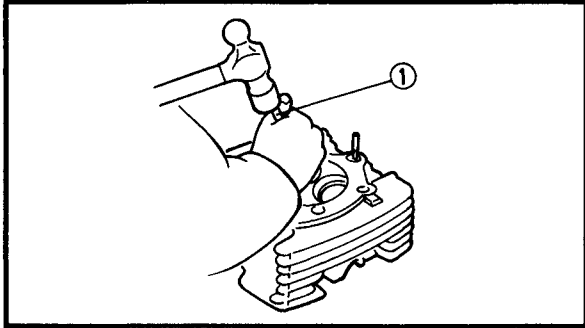

302-013

2. Replace:

- Valve guide

Replacement steps:

NOTE:

To ease guide removal, installation and to maintain correct fit heat the cylinder head in an oven to 100°C (212°F).

- Remove the valve guide using a valve guide remover (1).
- Install the new valve guide using a valve guide installer (2) and valve guide reamer (3).
- After installing the valve guide, bore the valve guide using a valve guide reamer (3) to obtain proper stem-to-guide clearance.



Valve guide remover (7 mm):
P/N. YM-01225-A, 90890-01225

Valve guide installer:
P/N. YM-04017, 90890-04017

Valve guide reamer (7 mm):
P/N. YM-01227, 90890-01227

NOTE:

After replacing the valve guide reface the valve seat.

3. Inspect:

- Valve face
Pitting/wear → Grind the face.
- Valve stem end
Mushroom shape or diameter larger than the body of the stem → Replace.

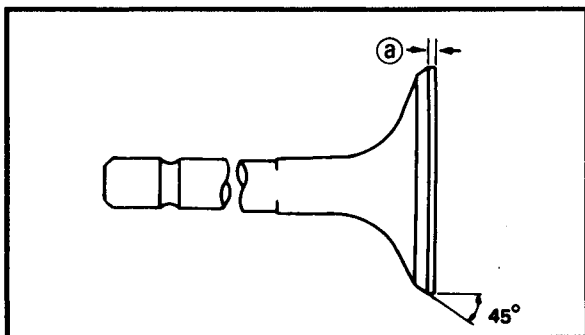

4. Measure:

- Margin thickness (a)
Out of specification → Replace.



Margin thickness:

Intake:
1.35 ~ 1.65 mm (0.053 ~ 0.065 in)
<Limit>: 1.2 mm (0.047 in)

Exhaust:
1.15 ~ 1.45 mm (0.045 ~ 0.057 in)
<Limit>: 1.0 mm (0.039 in)

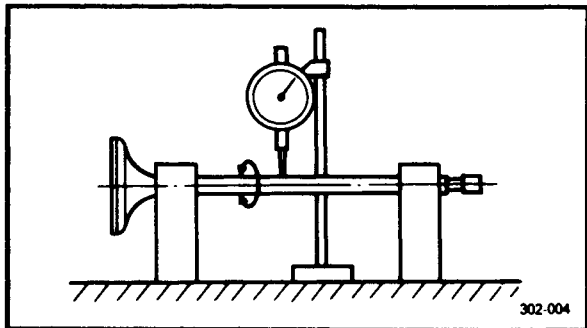

5.Measure:

- Runout (valve stem)
Out of specification → Replace.

	<p>Runout limit: 0.01 mm (0.0004 in)</p>
--	--

NOTE:

- When installing a new valve always replace the guide.
- If the valve is removed or replaced always replace the oil seal.

6.Eliminate:

- Carbon deposits
(from the valve face and valve seat)

7.Inspect:

- Valve seats
Pitting/wear → Reface the valve seat.

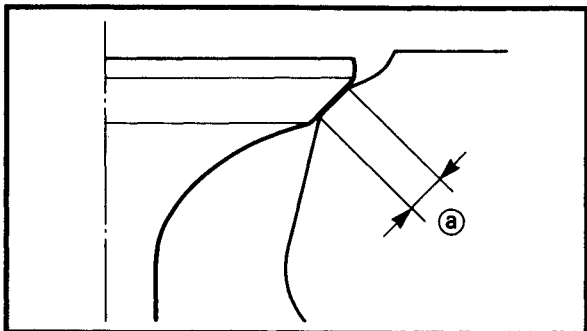

8.Measure:

- Valve seat width ①
Out of specification → Reface the valve seat.

	<p>Valve seat width:</p> <p>Intake: 1.0 ~ 1.2 mm (0.039 ~ 0.047 in) <Limit>: 1.6 mm (0.063 in)</p> <p>Exhaust: 1.0 ~ 1.2 mm (0.039 ~ 0.047 in) <Limit>: 1.6 mm (0.063 in)</p>
--	--

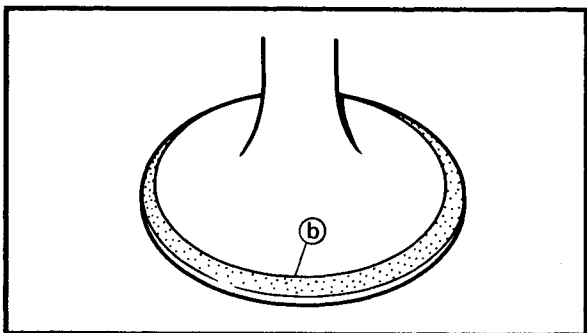

Measurement steps:

- Apply Mechanic's blueing dye (Dykem) ② to the valve face.
- Install the valve into the cylinder head.
- Press the valve through the valve guide and onto the valve seat to make a clear pattern.
- Measure the valve seat width. Where the valve seat and valve face made contact, blueing will have been removed.
- If the valve seat is too wide, too narrow, or the seat is not centered, the valve seat must be refaced.

- 9.Lap:
- Valve face
 - Valve seat

NOTE: _____
 After refacing the valve seat or replacing the valve and valve guide, the valve seat and valve face should be lapped.

Lapping steps:

- Apply a coarse lapping compound to the valve face.

CAUTION: _____
 Do not let the compound enter the gap between the valve stem and the guide.

- Apply molybdenum disulfide oil to the valve stem.
- Install the valve into the cylinder head.
- Turn the valve until the valve face and valve seat are evenly polished, then clean off all of the compound.

NOTE: _____
 For best lapping results, lightly tap the valve seat while rotating the valve back and forth between your hands.

- Apply a fine lapping compound to the valve face and repeat the above steps.

NOTE: _____
 After every lapping operation be sure to clean off all of the compound from the valve face and valve seat.

- Apply Mechanic's blueing dye (Dykem) to the valve face.
- Install the valve into the cylinder head.
- Press the valve through the valve guide and onto the valve seat to make a clear pattern.
- Measure the valve seat width again. If the valve seat width is out of specification, reface and relap the valve seat.

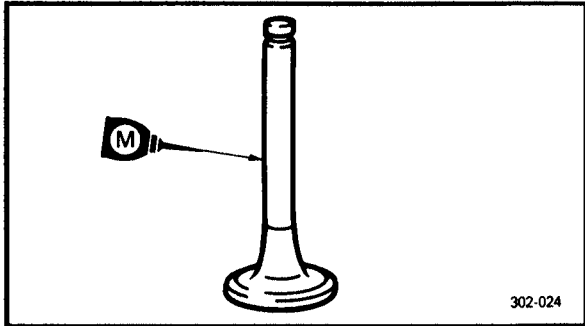
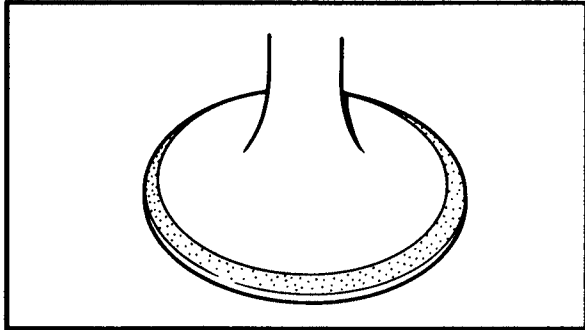

302-024

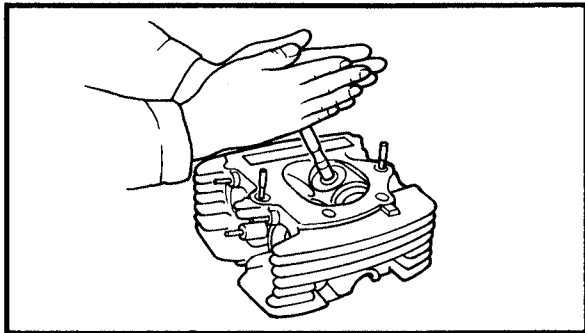

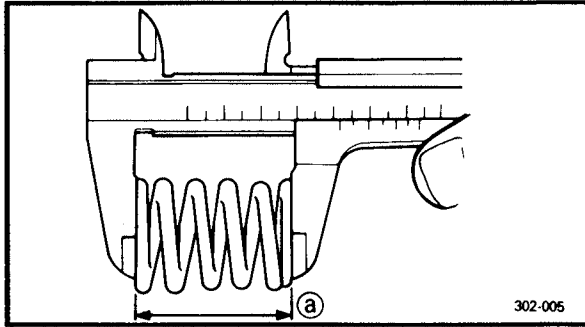

302-005

10. Measure:

- Valve spring free length **(a)**
Out of specification → Replace.



Free length (valve spring):

Inner:

40.1 mm (1.58 in)

<Limit>: 38.1 mm (1.50 in)

Outer:

43.8 mm (1.72 in)

<Limit>: 41.6 mm (1.64 in)

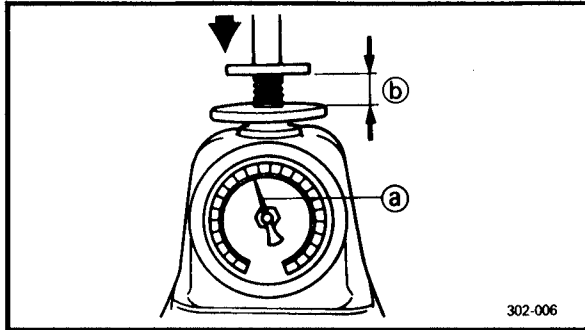

302-006

11. Measure:

- Compressed spring force **(a)**
Out of specification → Replace.
- Installed length **(b)**



Compressed spring force:

Inner:

7.3 ~ 8.9 kg at 31.2 mm

(16.1 ~ 19.2 lb at 1.23 in)

Outer:

15.2 ~ 18.6 kg at 34.2 mm

(33.5 ~ 41.0 lb at 1.35 in)

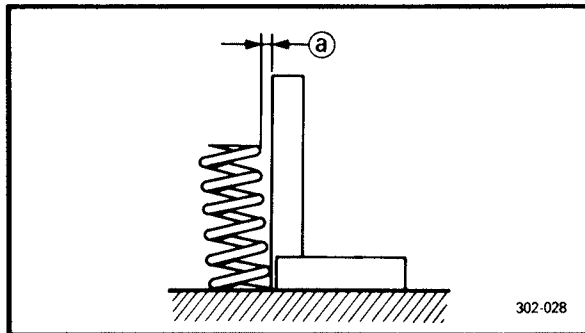

302-028

12. Measure:

- Spring tilt **(a)**
Out of specification → Replace.



Spring tilt limit:

Inner:

2.5°/1.7 mm (0.067 in)

Outer:

2.5°/1.9 mm (0.075 in)

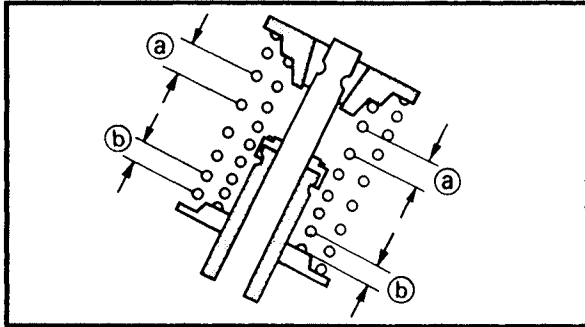

VALVE AND VALVE SPRING INSTALLATION

1. Apply:

- Molybdenum disulfide oil
(onto the valve stem and valve stem seal)

2. Install:

- Valve spring seats
- Valve stem seals **New**
- Valves
- Valve springs (inner and outer)
- Valve spring retainers

NOTE:

Install the valve springs with the larger pitch **a** facing upwards.

b Smaller pitch

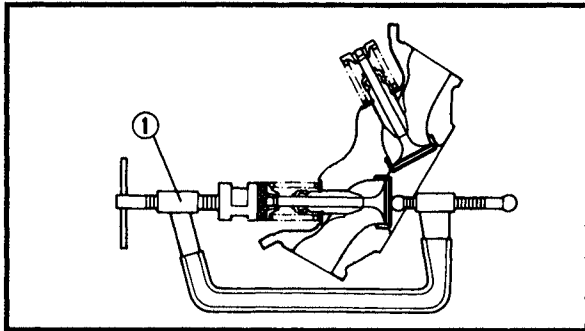

3. Install:

- Valve cotters

NOTE:

While compressing the valve spring with a valve spring compressor **1** install the valve cotters.



Valve spring compressor:
P/N. YM-04019, 90890-04019

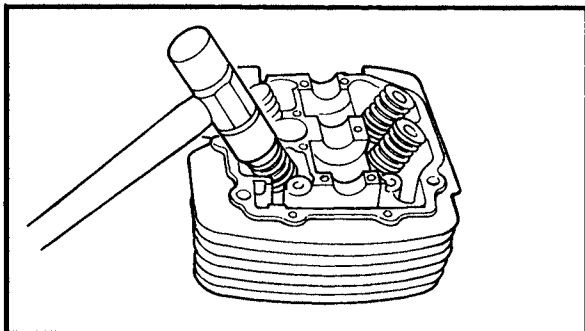

4. To secure the valve cotters onto the valve stem lightly tap the valve tip with a piece of wood.

CAUTION:

Hitting the valve tip with excessive force could damage the valve.



CYLINDER AND PISTON

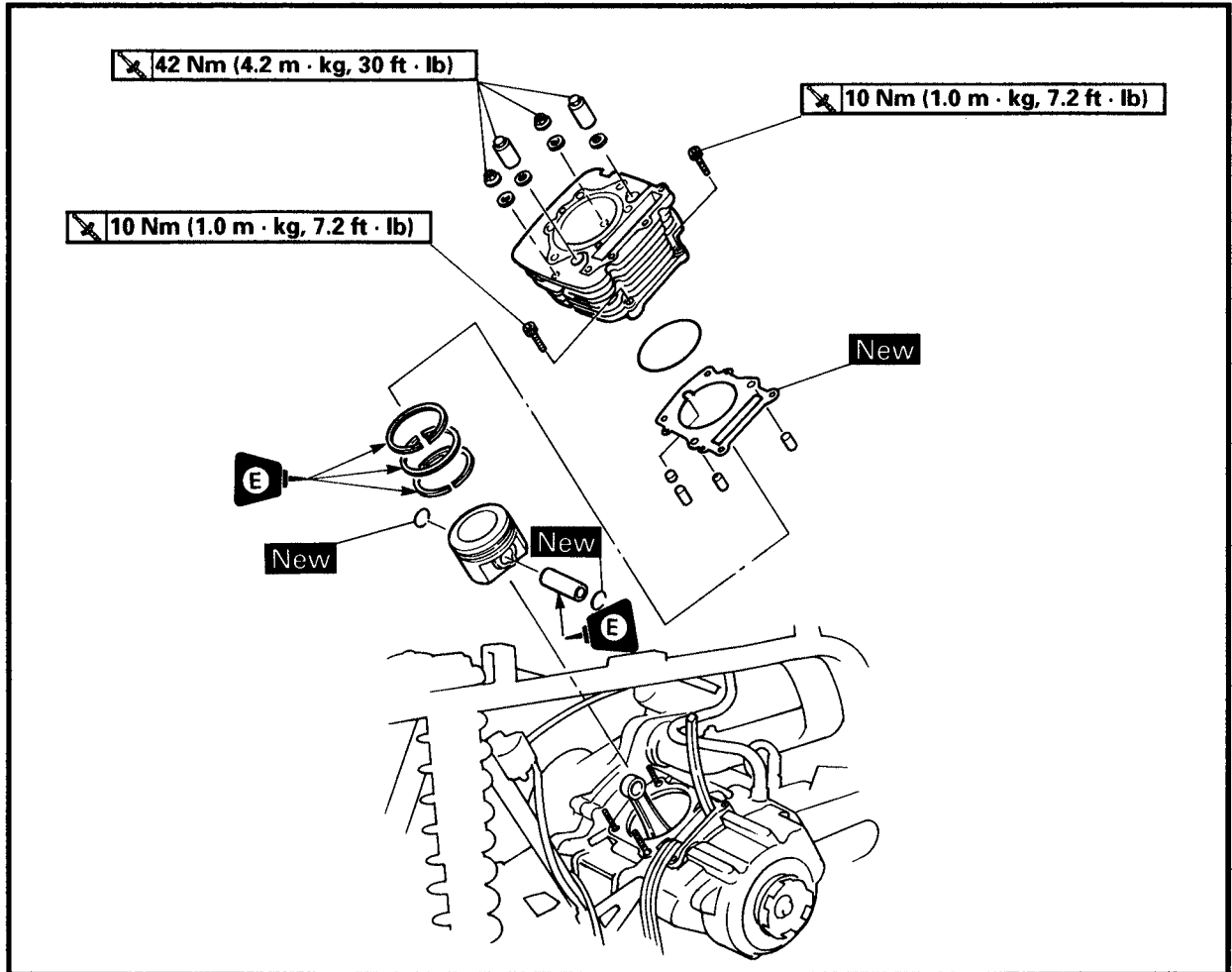

Order	Job name/Part name	Q'ty	Remarks
	Cylinder and piston removal		Remove the parts in the order below. Refer to "CYLINDER HEAD".
1	Cylinder head		Refer to "CYLINDER INSTALLATION".
2	Cylinder / O-ring	1/1	
3	Cylinder gasket	1	
4	Dowel pin	2	
5	Dowel pin / gasket	1/1	
6	Piston pin clip	2	Refer to "PISTON REMOVAL / INSTALLATION".
7	Piston pin	1	
8	Piston	1	
	Piston ring set	1	
			For installation, reverse the removal procedure.

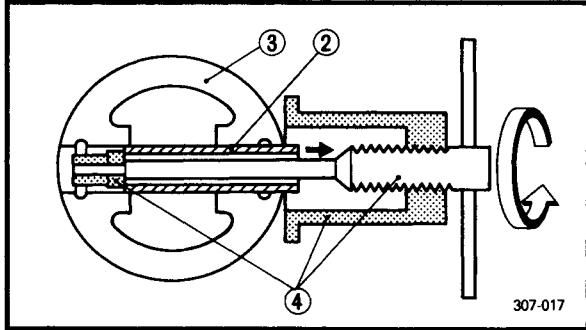
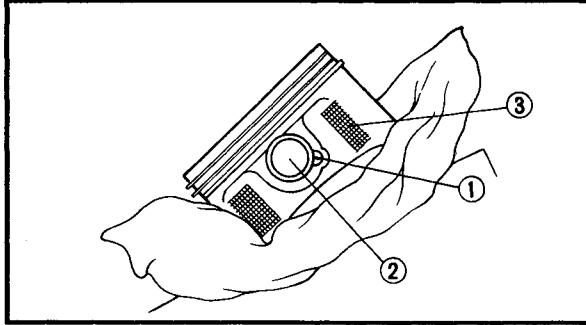

PISTON REMOVAL

1.Remove:

- Piston pin clips ①
- Piston pin ②
- Piston ③

NOTE:

- Put identification marks on each piston head for reference during reinstallation.
- Before removing each piston pin, deburr the clip groove and pin hole area. If the piston pin groove is deburred and the piston pin is still difficult to remove, use the piston pin puller ④.



Piston pin puller:
P/N. YU-01304, 90890-01304

CAUTION:

Do not use a hammer to drive the piston pin out.

2.Remove:

- Piston rings

NOTE:

Spread the end gaps apart while at the same time lifting the piston ring over the top of the piston crown, as shown in the illustration.

CYLINDER AND PISTON INSPECTION

1.Inspect:

- Cylinder and piston walls
Vertical scratches → Rebore or replace the cylinder and the piston.

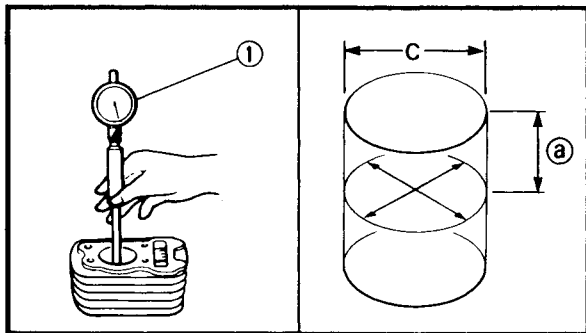

2.Measure:

- Piston-to-cylinder clearance

Measurement steps:

1st step:

- Measure the cylinder bore "C" with a cylinder bore gauge ①.
- ① 40 mm (1.6 in) from the top of the cylinder

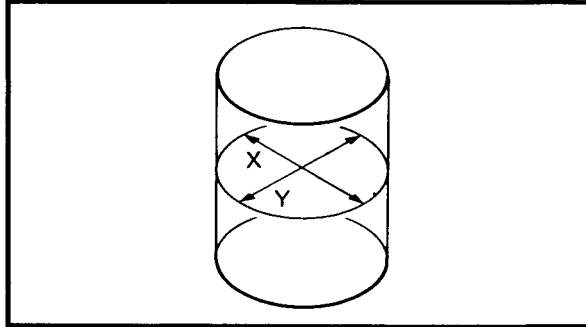

NOTE: Measure cylinder bore "C" in parallel to and at right angles to the cylinder matching surface. Then, find the average of the measurements.

	Standard	Wear limit
Cylinder bore "C"	94.97 ~ 95.02 mm (3.739 ~ 3.741 in)	95.1 mm (3.744 in)
$C = \frac{X+Y}{2}$		

- If out of specification, rebore or replace the cylinder, and replace the piston and piston rings as a set.

2nd step

- Measure piston skirt diameter "P" with a micrometer.
- ⓑ 5.0 mm (0.20 in) from the piston bottom edge

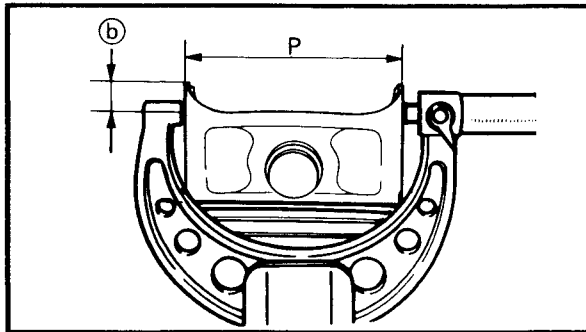

	Piston skirt diameter "P"	
Standard	94.915 ~ 94.965 mm (3.737 ~ 3.739 in)	

- If out of specification, replace the piston and piston rings as a set.

3rd step

- Find the piston-to-cylinder clearance with the following formula.

Piston-to-cylinder clearance=
Cylinder bore "C" —
Piston skirt diameter "P"

Piston-to-cylinder clearance: 0.045 ~ 0.065 mm (0.0018 ~ 0.0026 in) <Limit: 0.15 mm (0.0059 in)>

- If out of specification, rebore or replace the cylinder, and replace the piston and piston rings as a set.

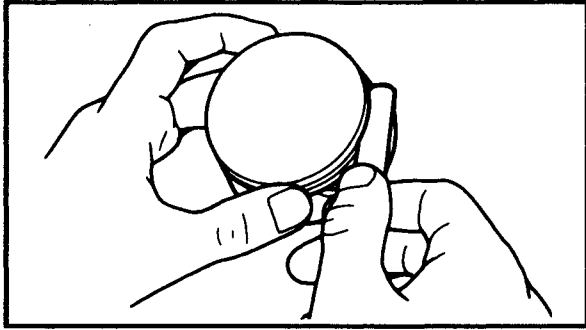

PISTON RING INSPECTION

1. Measure:

- Ring side clearance
Use a feeler gauge ①.
Out of specification → Replace the piston and rings as a set.

NOTE:

Clean carbon from the piston ring grooves and rings before measuring the side clearance.

	Side clearance	
	Standard	Limit
Top ring	0.04 ~ 0.08 mm (0.002 ~ 0.003 in)	0.13 mm (0.005 in)
2nd ring	0.03 ~ 0.07 mm (0.001 ~ 0.003 in)	0.13 mm (0.005 in)

2. Position:

- Piston ring
(in cylinder)

NOTE:

Insert a ring into the cylinder and push it approximately 40 mm (1.6 in) into the cylinder. Push the ring with the piston crown so that the ring will be at a right angle to the cylinder bore.

① 40 mm (1.6 in)

3. Measure:

- Ring end gap
Out of specification → Replace.

NOTE:

You cannot measure the end gap on the expander spacer of the oil control ring. If the oil control ring rails show excessive gap, replace all three rings.

	End gap	
	Standard	Limit
Top ring	0.30 ~ 0.45 mm (0.012 ~ 0.018 in)	0.7 mm (0.028 in)
2nd ring	0.30 ~ 0.45 mm (0.012 ~ 0.018 in)	0.8 mm (0.031 in)
Oil ring	0.20 ~ 0.70 mm (0.008 ~ 0.028 in)	—

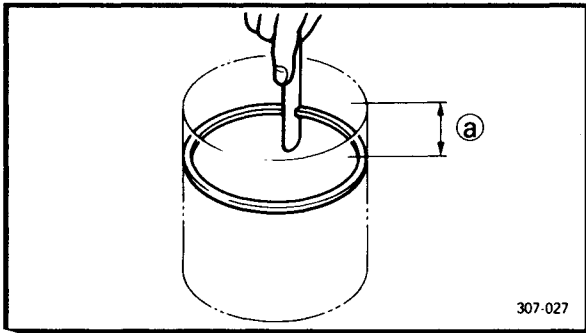

307-027



PISTON PIN INSPECTION

1. Inspect:

- Piston pin
Blue discoloration/grooves →
Replace, then inspect the lubrication system.

2. Measure:

- Piston pin-to-piston clearance

Measurement steps:

- Measure the piston pin outside diameter (a).
If out of specification, replace the piston pin.

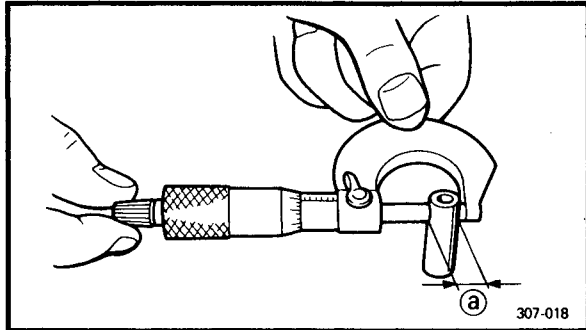

Outside diameter (piston pin):
21.991 ~ 22.000 mm
(0.8658 ~ 0.8661 in)

- Measure the piston inside diameter (b).
- Calculate the piston pin-to-piston clearance with the following formula.

Piston pin-to-piston clearance =
Bore size (piston pin) (b) -
Outside diameter (piston pin) (a)

- If out of specification, replace the piston.



Piston pin-to-piston clearance:
0.004 ~ 0.024 mm
(0.00016 ~ 0.00094 in)
<Limit: 0.07 mm (0.003 in)>

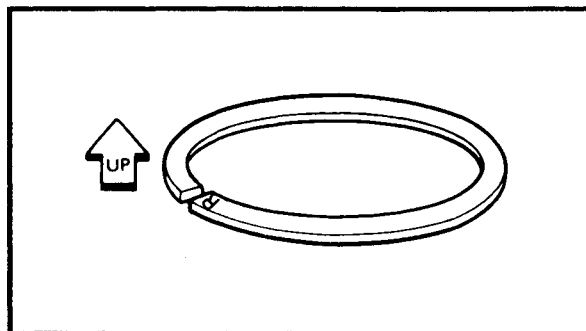
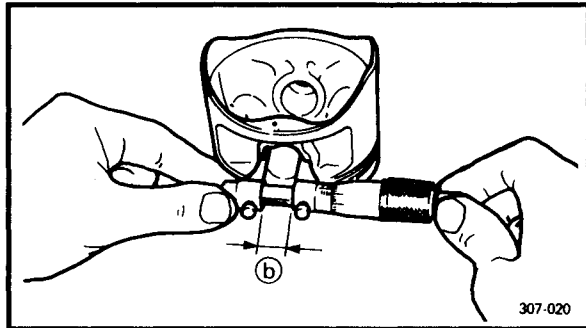

PISTON INSTALLATION

1. Install:

- Piston rings
(onto the piston)

NOTE:

- Be sure to install the piston rings so that the manufacturer's marks or numbers are located on the upper side of the rings.
- Lubricate the piston and piston rings liberally with engine oil.

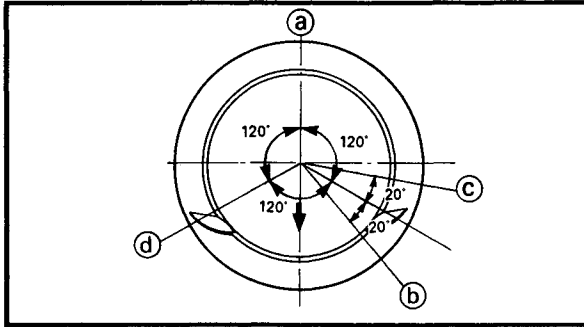

2.Position:

- Top ring
- 2nd ring
- Oil ring

Offset the piston ring end gaps as shown.

- Ⓐ Top ring end
- Ⓑ Oil ring end (lower)
- Ⓒ Oil ring end (upper)
- Ⓓ 2nd ring end

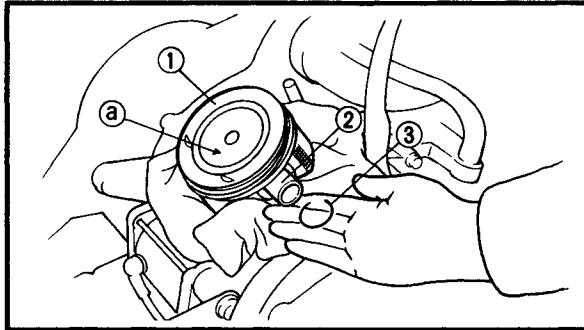

3.Install:

- Piston ①
- Piston pin ②
- Piston pin clips ③ **New**

NOTE:

- Apply engine oil onto the piston pin, piston ring and piston.
- Be sure that the arrow mark Ⓐ on the piston points to the exhaust side of the engine.
- Before installing the piston pin clip, cover the crankcase with a clean rag to prevent the piston pin clip from falling into the crankcase.

4.Lubricate:

- Piston
- Piston rings
- Cylinder

NOTE:

Apply a liberal coating of engine oil.

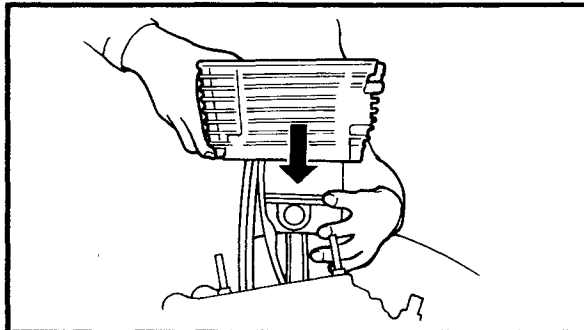

CYLINDER INSTALLATION

1.Install:

- Cylinder
- Nuts (M10)
- Bolts (M6)

42 Nm (4.2 m · kg, 30 ft · lb)

10 Nm (1.0 m · kg, 7.2 ft · lb)

NOTE:

Install the cylinder with one hand while compressing the piston rings with the other hand.

CAUTION:

- Be careful not to damage the timing chain damper during installation.
- Pass the timing chain through the timing chain cavity.

RECOIL STARTER AND CDI MAGNETO

ENG



RECOIL STARTER AND CDI MAGNETO

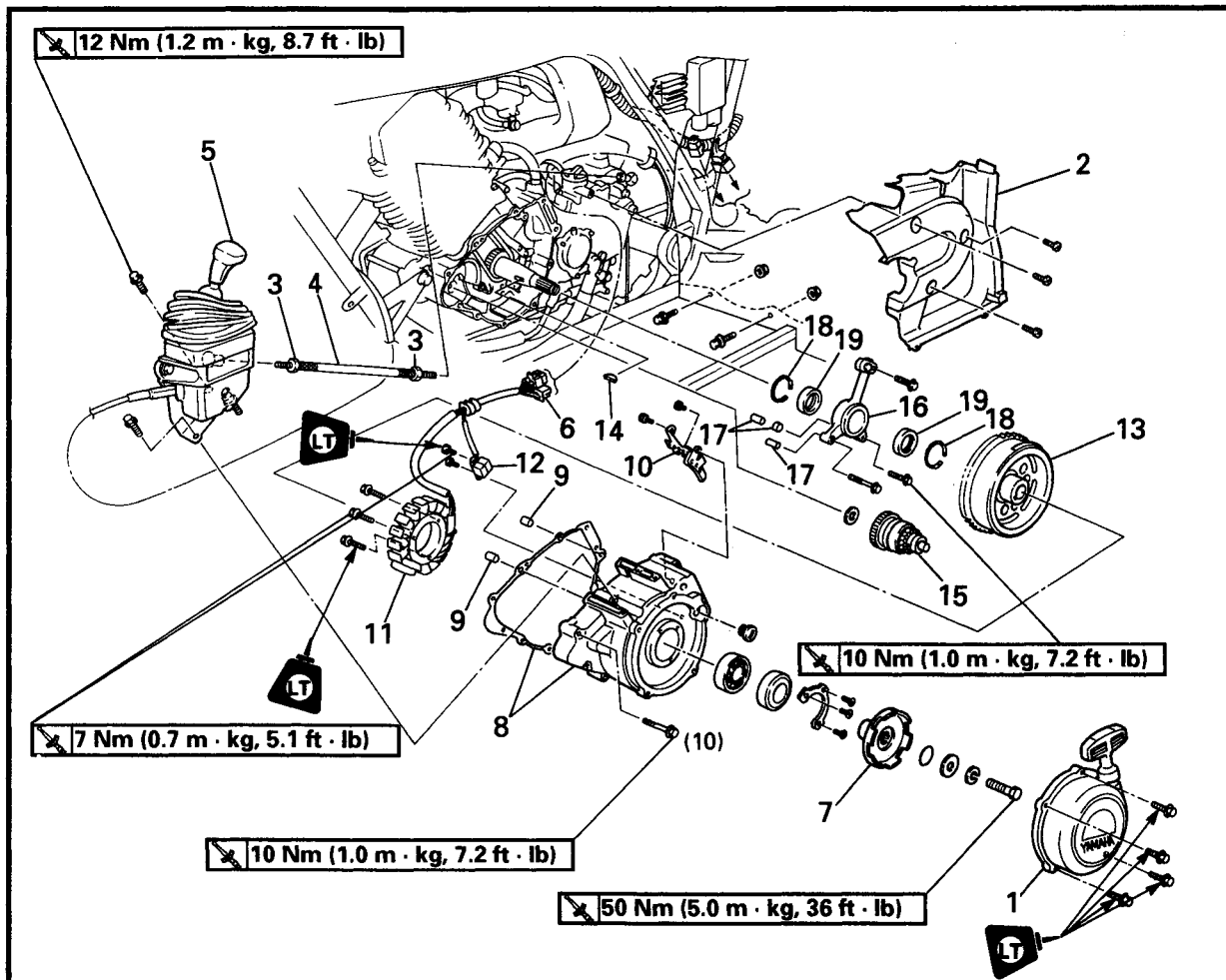

Order	Job name/Part name	Q'ty	Remarks
	CDI magneto removal		Remove the parts in the order below.
	Engine oil		Drain Refer to "ENGINE OIL REPLACEMENT" in CHAPTER 3.
	Front fender		Refer to "SEAT, CARRIERS, FENDERS AND FUEL TANK" in CHAPTER 3.
1	Recoil starter assembly	1	Loosen. 1 of 2 has LH thread
2	Cover	1	
3	Locknut	2	Refer to "CDI MAGNETO INSTALLATION".
4	Select lever shift rod	1	
5	Select lever unit	1	Refer to "CDI MAGNETO REMOVAL / INSTALLATION".
6	CDI magneto coupler	1	
7	Starter pulley	1	
8	Crankcase cover (left) / gasket	1/1	
9	Dowel pin	2	

RECOIL STARTER AND CDI MAGNETO

ENG

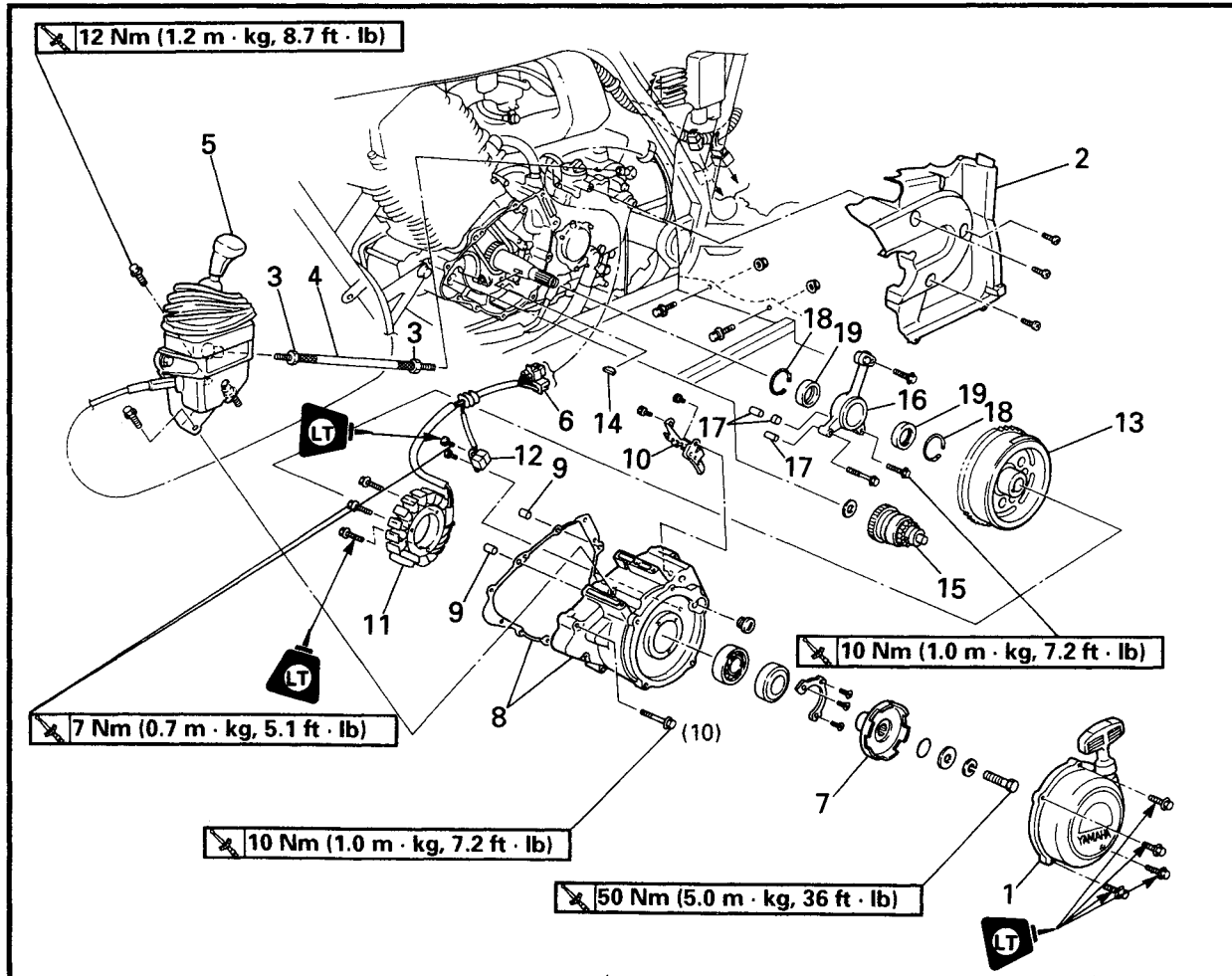

Order	Job name/Part name	Q'ty	Remarks
10	Lead holder	1	Refer to "CDI MAGNETO REMOVAL / INSTALLATION".
11	Starter coil	1	
12	Pickup coil	1	
13	CDI rotor	1	
14	Woodruff key	1	
15	Starter driven gear unit	1	
16	Oil delivery housing	1	
17	Dowel pin / gasket	2/1	
18	Circlip	2	
19	Oil seal	2	
			For installation, reverse the removal procedure.

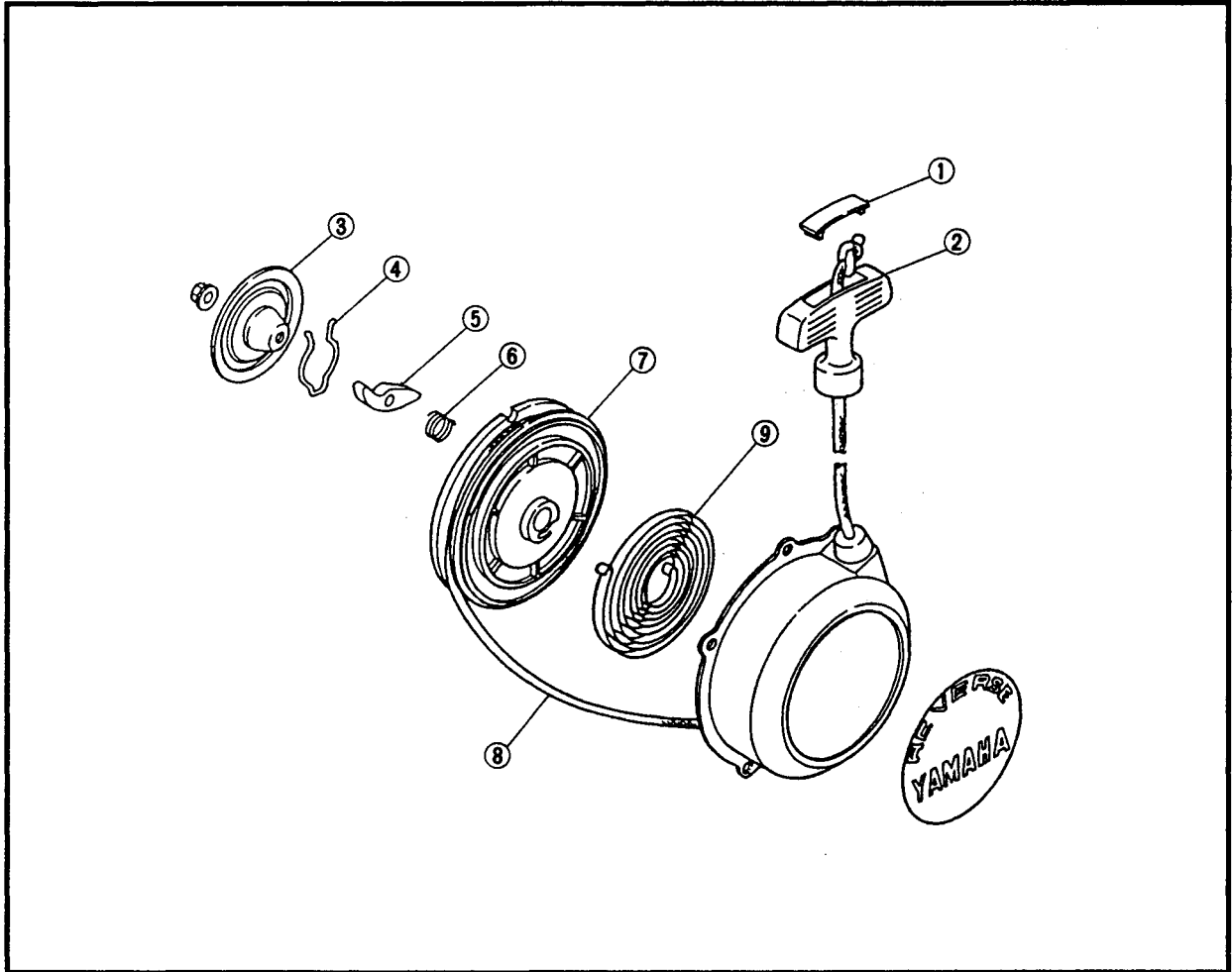

Order	Job name/Part name	Q'ty	Remarks
	Recoil starter disassembly		Disassemble the parts in the order below.
①	Cap	1	Refer to "RECOIL STARTER DISASSEMBLY / ASSEMBLY".
②	Starter handle	1	
③	Friction plate	1	
④	Pawl spring	1	
⑤	Drive pawl	1	
⑥	Spring	1	
⑦	Sheave drum	1	
⑧	Rope	1	
⑨	Coil spring	1	
			For assembly, reverse the disassembly procedure.



CDI MAGNETO REMOVAL

1.Remove:

- Select lever shift rod
- Select lever unit

NOTE: _____

Make sure that the select lever is NEUTRAL position.

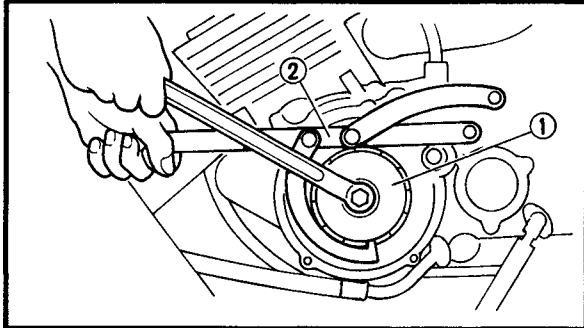

2.Remove:

- Starter pulley ①

NOTE: _____

Use the rotor holder ② to hold the starter pulley.



Rotor holder
P/N. YU-01235, 90890-01235

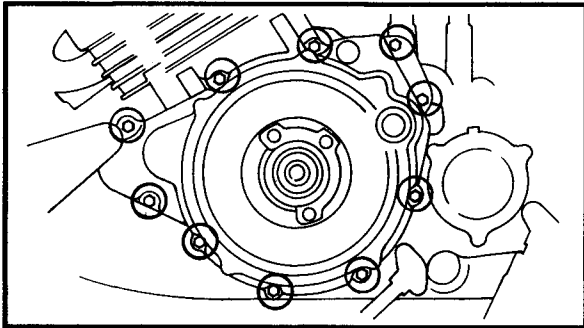

3.Remove:

- Crankcase cover (left)
- Gasket
- Dowel pins

NOTE: _____

Working in a crisscross pattern, loosen each bolt 1/4 of a turn. Remove them after all of them are loosened.

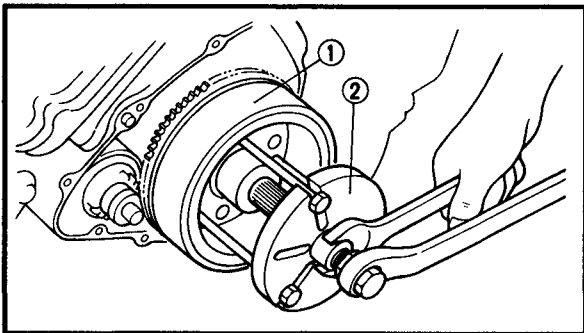

4.Remove:

- CDI rotor ①

NOTE: _____

Use the flywheel puller ②.



Flywheel puller:
P/N. YU-33270, 90890-01362

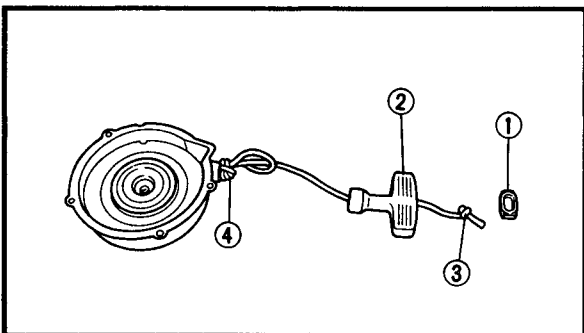

RECOIL STARTER DISASSEMBLY

1.Remove:

- Cap ①
- Starter handle ②

NOTE: _____

Before untying the knot ③ above the starter handle, make a knot ④ in the rope so that the rope is not pulled into the case.

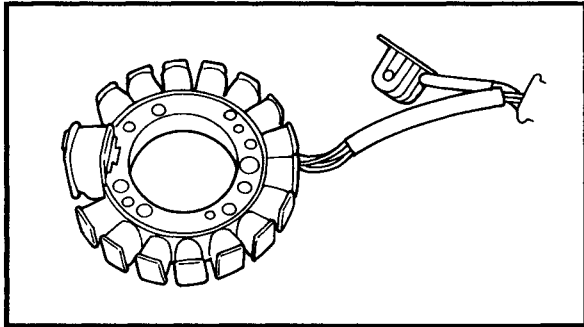

CDI MAGNETO INSPECTION

1. Inspect:
- Starter coil
 - Pickup coil
- Damage → Replace.

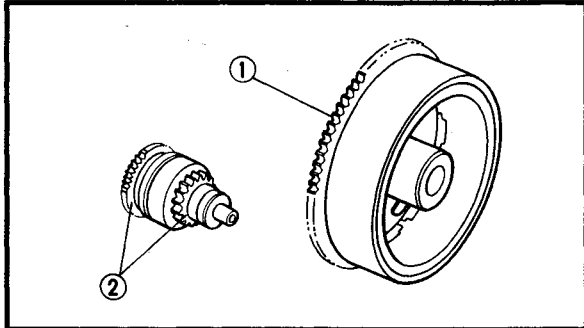

2. Inspect:
- Gear teeth (starter wheel) ①
 - Gear teeth (starter clutch) ②
- Burrs/chips/roughness/wear → Replace.

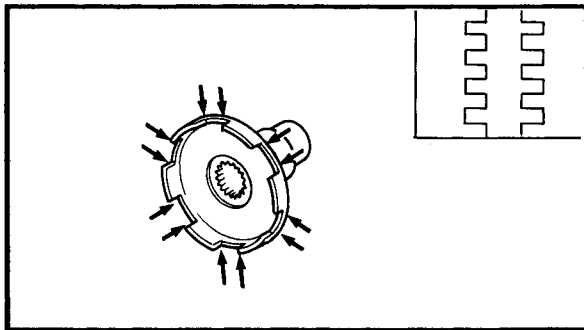

STARTER PULLEY INSPECTION

1. Inspect:
- Starter pulley
- Cracks/pitting → Deburr or replace.

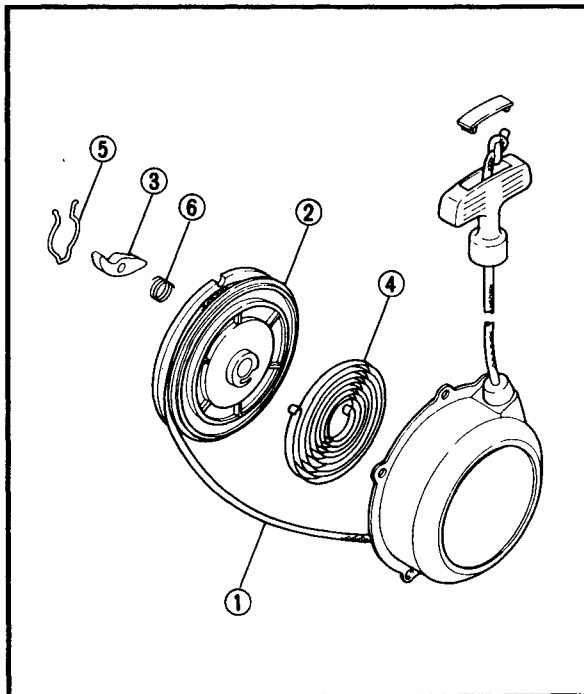

RECOIL STARTER INSPECTION

1. Inspect:
- Rope ①
 - Sheave drum ②
 - Drive pawl ③
- Wear/damage → Replace.
- Coil spring ④
 - Pawl spring ⑤
 - Spring ⑥
- Fatigue → Replace.

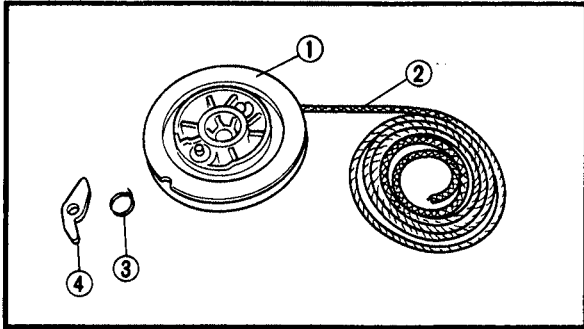

RECOIL STARTER ASSEMBLY

1. Install:

- Sheave drum ①
- Rope ②
- Pawl spring ③
- Drive pawl ④

NOTE:

Wind the rope 4-1/2 turns clockwise around the sheave drum. Then insert the rope into the drum slit ①.

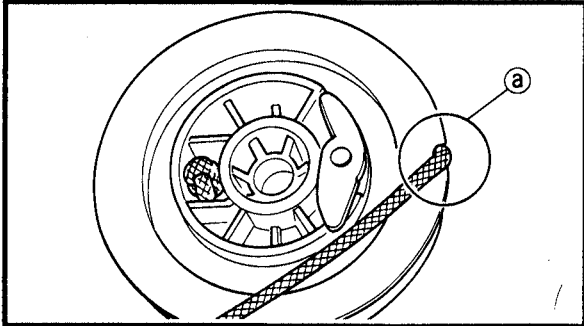

2. Install:

- Starter spring ①
- Sheave drum assembly ②

NOTE:

- Mesh the spring hook ③ with the case slit, then wind the spring clockwise into the case from the larger to smaller diameter.
- Mesh the sheave drum hook ④ with the spring hook ⑤.

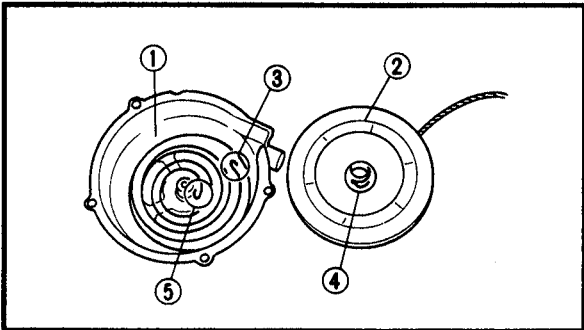

3. Install:

- Spring ①
- Friction plate ②
- Nut

NOTE:

Insert the spring hooks into the pawl side holes.

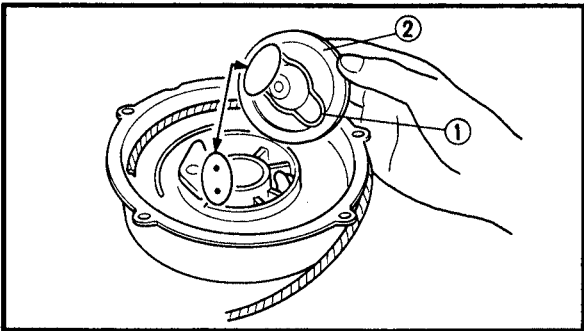

4. Turn the sheave drum 3-turn clockwise to give preload to the spring.

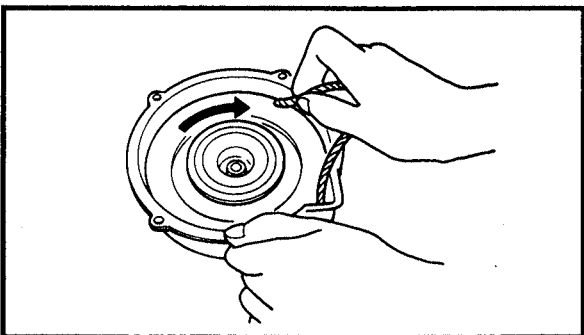

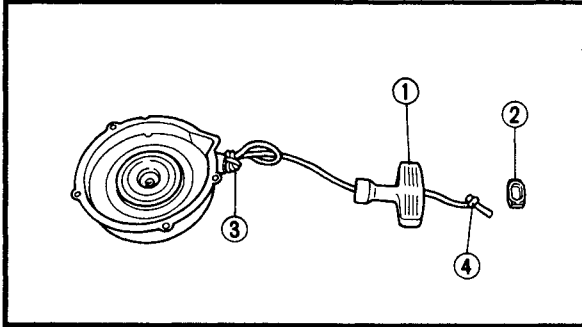

5. Install:

- Starter handle ①
- Cap ②

NOTE:

- Pass the rope through the case hole and make a knot ③ on the rope so that the rope is not pulled into the case.
- Untie the knot ③ after making a knot ④ above the handle.

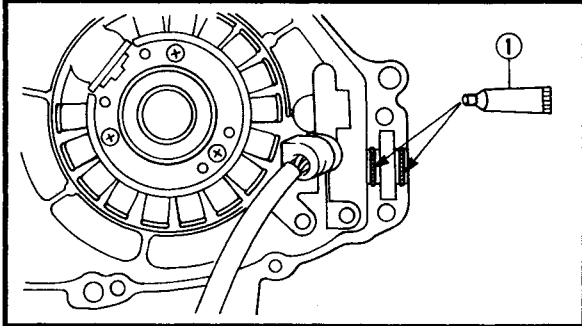

CDI MAGNETO INSTALLATION

1. Apply:

- Sealant (Quick Gasket®) ①
(into the slit)



Sealant (Quick Gasket®):
P/N. ACC-11001-05-01
Yamaha bond No. 1215®:
P/N. 90890-85505

2. Install:

- Woodruff key
- CDI rotor

NOTE:

- Before installing the rotor, clean the outside of the crankshaft and the inside of the rotor.
- After installing the rotor, check that the rotor rotates smoothly. If not, reinstall the key and rotor.

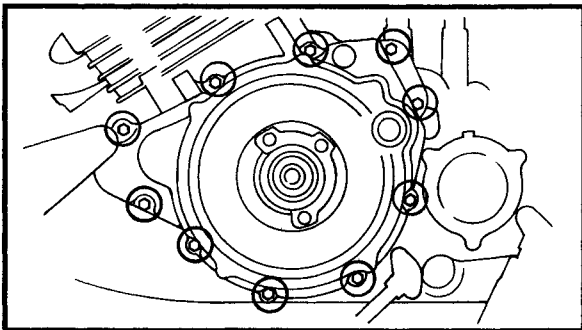

3. Install:

- Dowel pins
- Gasket **New**
- Crankcase cover (left)

10 Nm (1.0 m · kg, 7.2 ft · lb)

NOTE:

- When installing the crankcase cover (left), use a long rod to hold the CDI rotor in position from the outside. This will make assembly easier. Be careful not to damage the oil seal.
- Tighten the bolts in stages, using a criss-cross pattern.

RECOIL STARTER AND CDI MAGNETO

ENG

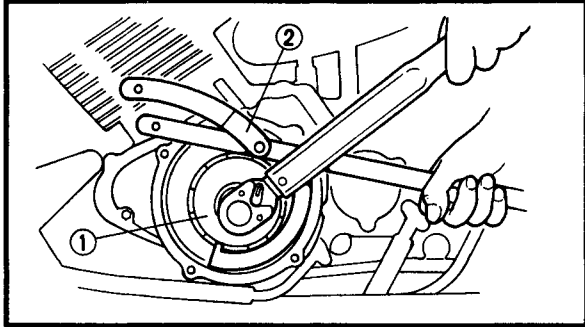

4.Install:

- Starter pulley ①

 50 Nm (5.0 m · kg, 36 ft · lb)

NOTE: _____

Use a rotor holder ② to hold the starter pulley.



Rotor holder
P/N. YU-01235, 90890-01235

NOTE: _____

Before installing the starter pulley, do not forget to install the O-ring.

5.Install:

- Select lever unit
- Select lever shift rod

NOTE: _____

Before installing the select lever shift rod, make sure that the select lever and shift cam is NEUTRAL position.

6.Adjust:

- Select lever shift rod
Refer to "SELECT LEVER CONTROL CABLE AND SHIFT ROD" in CHAPTER 3.



PRIMARY AND SECONDARY SHEAVES

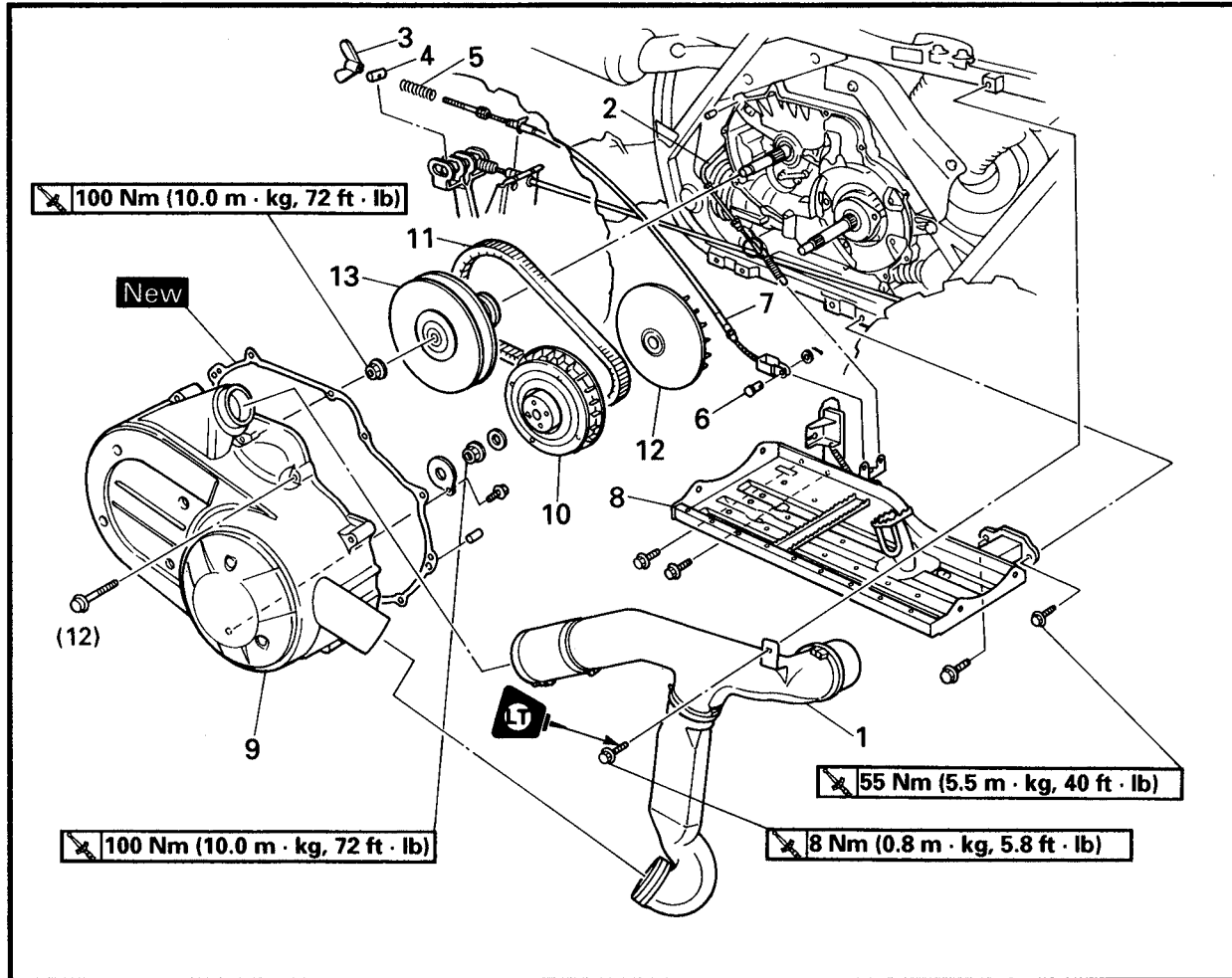

Order	Job name/Part name	Q'ty	Remarks
	Primary and secondary sheave removal		Remove the parts in the order below.
	Front fender		Refer to "SEAT, CARRIERS, FNDERS, FUEL TANK" in CHAPTER 3.
	Rear fender		
1	Air duct assembly	1	
2	Reverse control cable	1	
3	Brake pedal adjuster	1	
4	Pin	1	
5	Spring	1	
6	Pin	1	
7	Rear brake cable	1	
8	Footrest board (right)	1	
9	Crankcase cover (right)	1	

PRIMARY AND SECONDARY SHEAVES

ENG

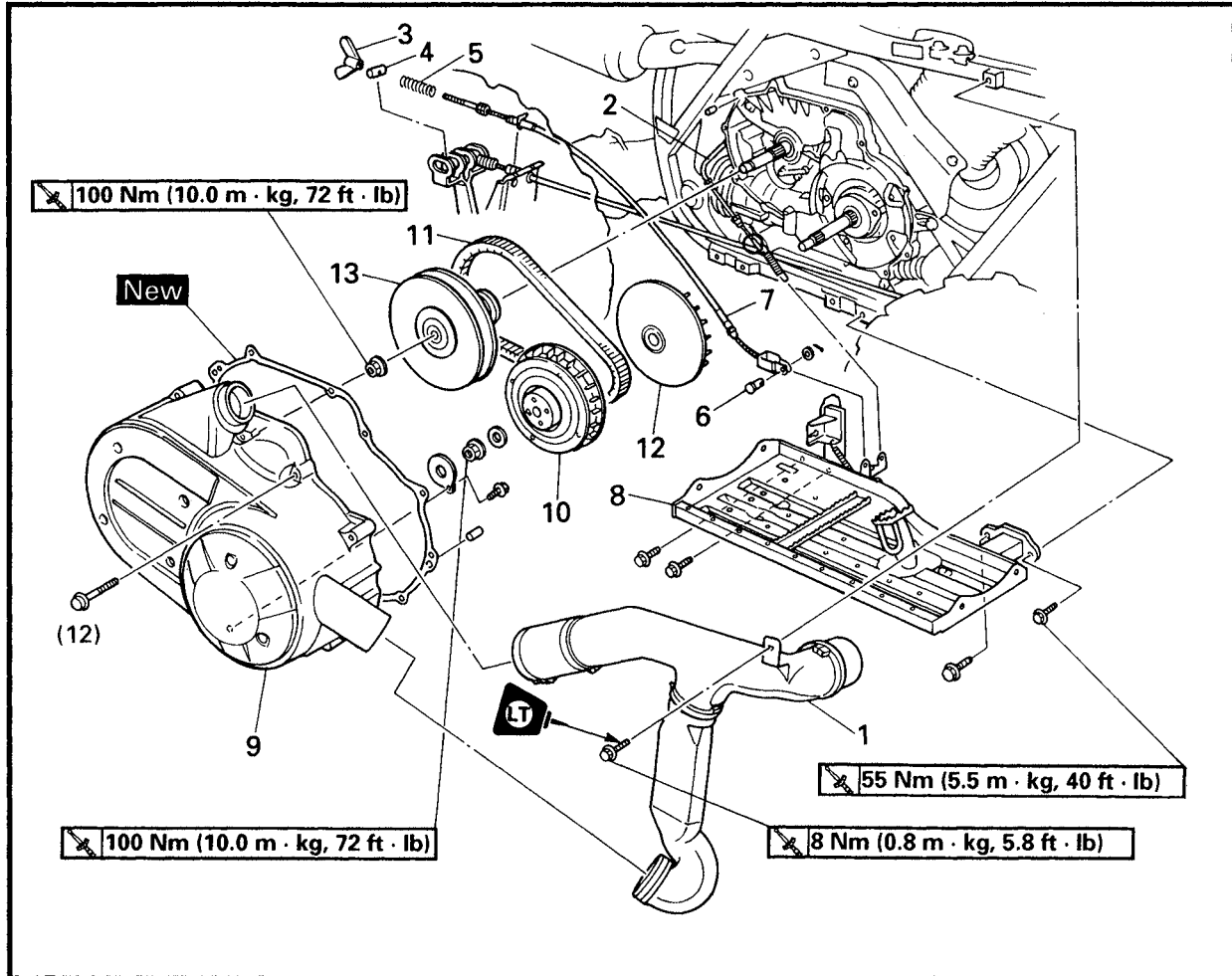

Order	Job name/Part name	Q'ty	Remarks
10	Primary sheave assembly	1	Refer to "PRIMARY AND SECONDARY SHEAVES REMOVAL/INSTALLATION". For installation, reverse the removal procedure.
11	V-belt	1	
12	Primary fixed sheave	1	
13	Secondary sheave assembly	1	



PRIMARY SHEAVE

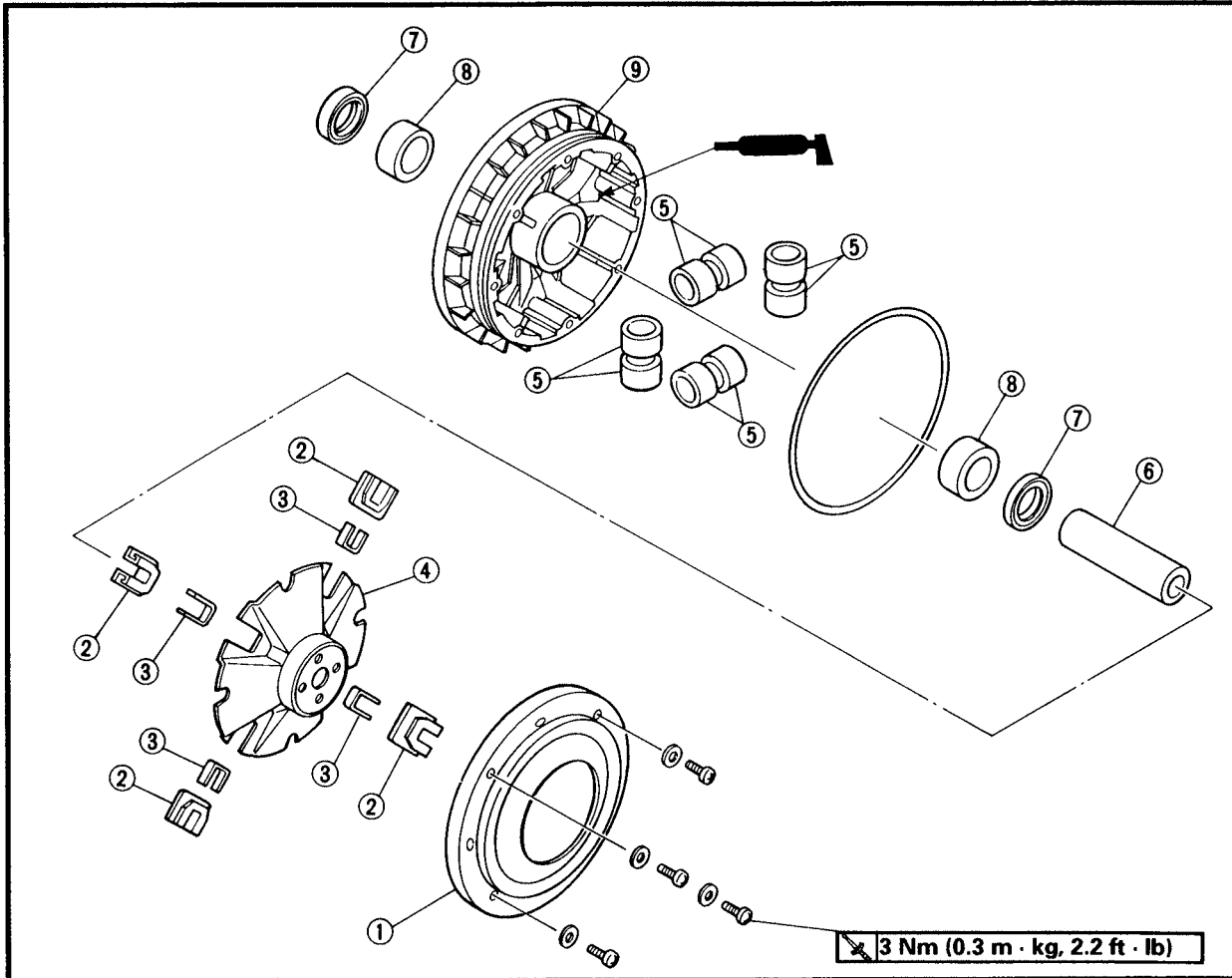

Order	Job name/Part name	Q'ty	Remarks
	Primary sheave disassembly		Disassemble the parts in the order below.
①	Primary pulley sheave cap	1	Refer to "PRIMARY SHEAVE ASSEMBLY".
②	Primary pulley slider	4	
③	Spacer	4	
④	Primary pulley cam	1	
⑤	Primary pulley weight	8	
⑥	Collar	1	
⑦	Oil seal	2	
⑧	Bush	2	
⑨	Primary sliding sheave	1	
			For assembly, reverse the disassembly procedure.



SECONDARY SHEAVE

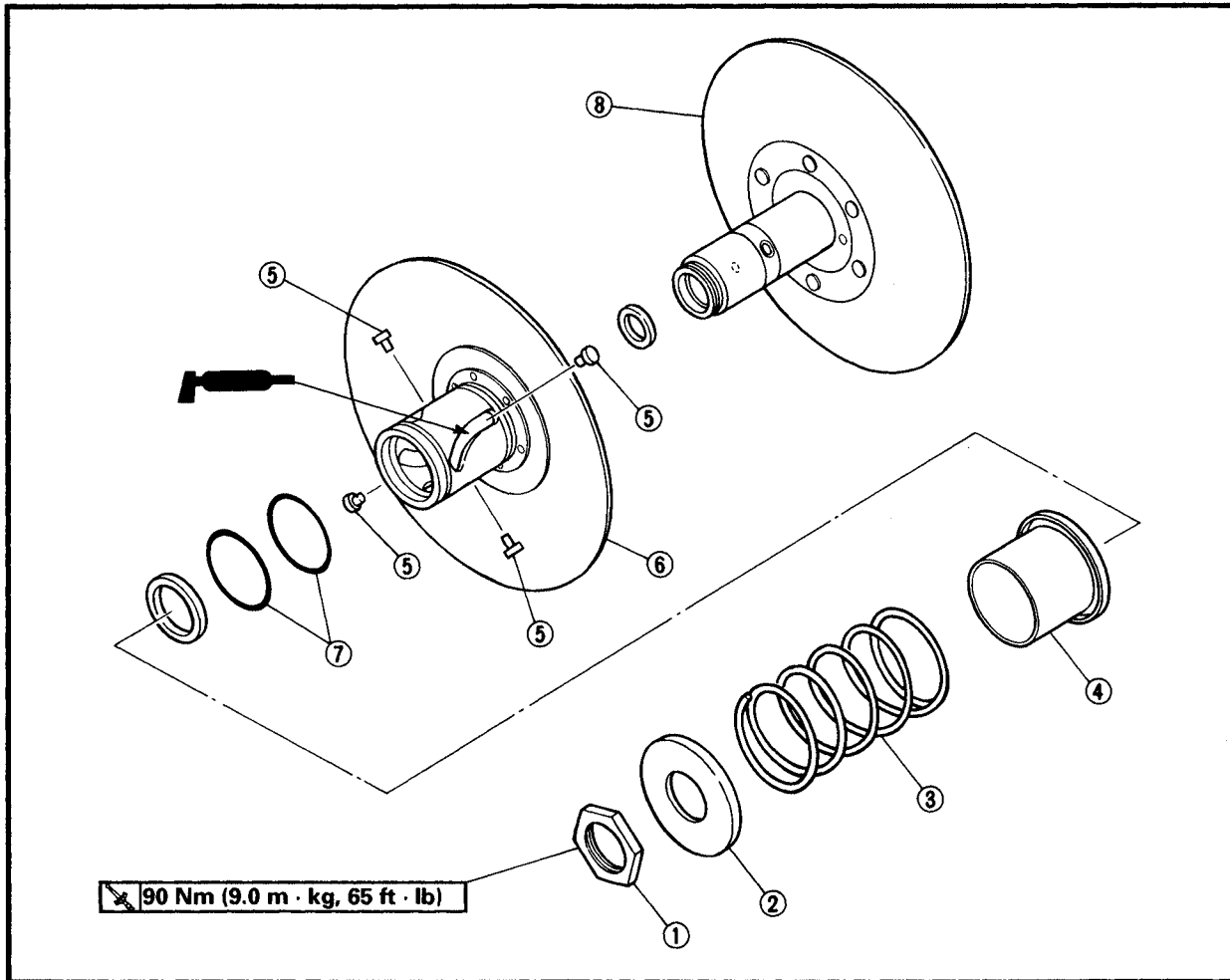

Order	Job name/Part name	Q'ty	Remarks
	Secondary sheave disassembly		Disassemble the parts in the order below.
①	Nut	1	Refer to "SECONDARY SHEAVE DIS-ASSEMBLY / ASSEMBLY".
②	Spring seat	1	
③	Compression spring	1	
④	Spring seat	1	
⑤	Guide pin	4	
⑥	Secondary sliding sheave	1	
⑦	O-ring	2	
⑧	Secondary fixed sheave	1	For assembly, reverse the disassembly procedure.

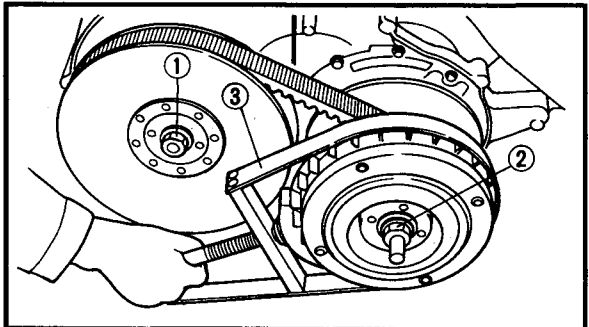

PRIMARY AND SECONDARY SHEAVES REMOVAL

1. Loosen:
- Nut (secondary sheave) ①
 - Nut (primary sheave) ②

NOTE:

- Use the sheave holder ③ to hold the primary sheave.
- First, loosen the nut (secondary sheave) ②, then loosen the nut (primary sheave) ①.

	<p>Sheave holder: P/N. YU-01880, 90890-01701</p>
---	---

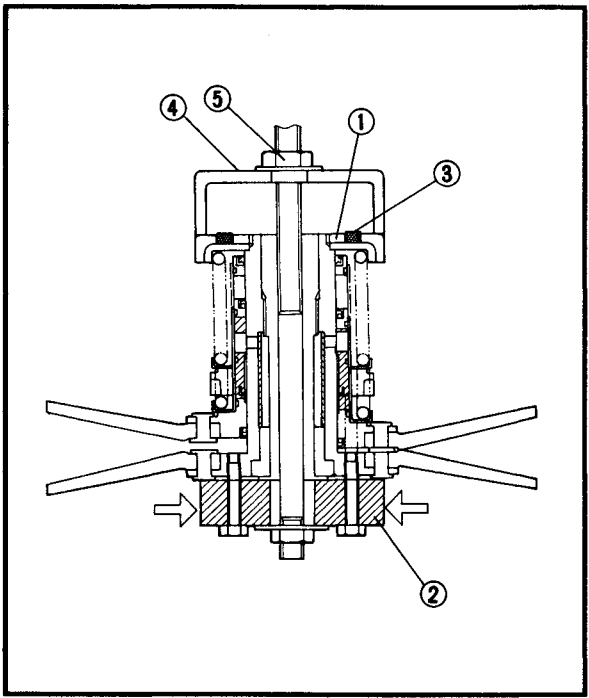

SECONDARY SHEAVE DISASSEMBLY

1. Remove:
- Nut ①

Removing steps:

- Attach the sheave fixed block ②, locknut wrench ③ and sheave spring compressor ④ to the secondary sheave assy.

	<p>Sheave fixed block P/N. YM-04135, 90890-04135 Locknut wrench P/N. 90890-01348 Sheave spring compressor P/N. YM-04134, 90890-04134</p>
---	---

- Place the sheave fixed block in a vise and secure it.
- Tighten the sheave spring compressor nut ⑤ and compress the spring.
- Loosen nut ① with the locknut wrench ③.
- Remove the nut ①.
- Remove the sheave spring compressor and locknut wrench.

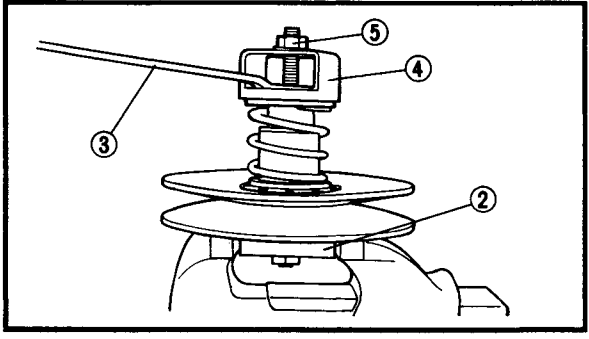

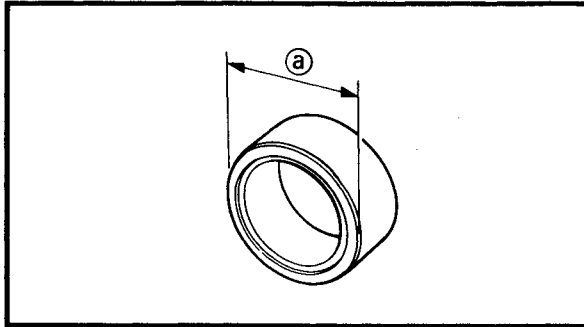

PRIMARY SHEAVE INSPECTION

1. Inspect:

- Weight outside diameter @
Out of specification → Replace the weight.



Weight outside diameter:
30 mm (1.18 in)
<Limit> : 29.5 mm (1.16 in)

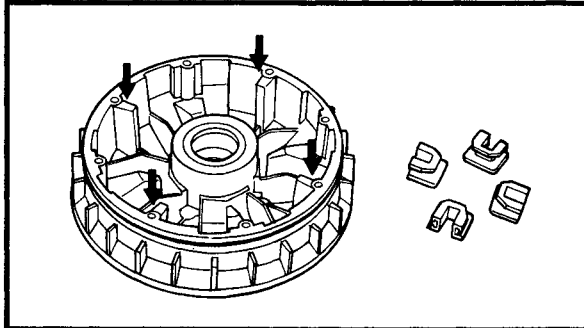

2. Inspect:

- Primary puller slider
- Primary sliding sheave splines
Wear/cracks/damage → Replace.
- Spacer
- Primary puller cam
Cracks/damage → Replace.

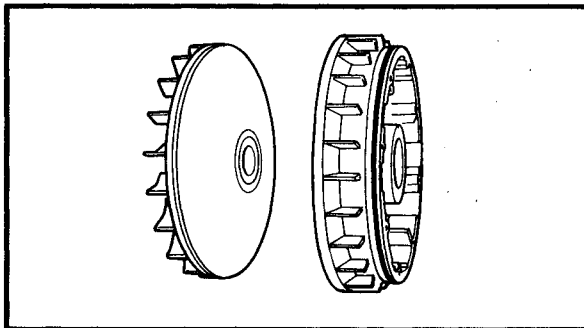

3. Inspect:

- Primary sliding sheave
- Primary fixed sheave
Cracks / damage → Replace.

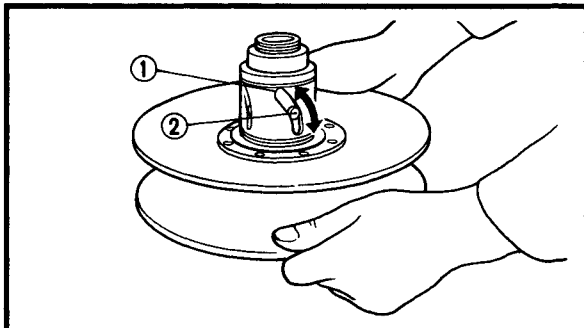

SECONDARY SHEAVE INSPECTION

1. Inspect:

- Secondary fixed sheave smooth operation
- Secondary sliding sheave smooth operation
Scratches/damage → Replace as a set.

2. Inspect:

- Torque cam groove ①
Wear/damage → Replace.

3. Inspect:

- Guide pin ②
Wear/damage → Replace.

4. Inspect:

- Secondary sheave spring
Damage → Replace.

5. Measure:

- Secondary sheave spring free length @
Out of specification → Replace the secondary sheave spring.

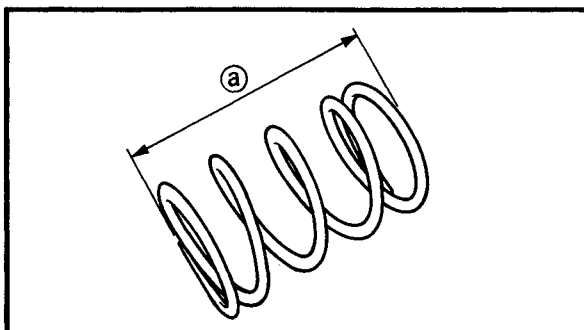

Free length:
125.9 mm (4.96 in)
<Limit> : 122.9 mm (4.83 in)

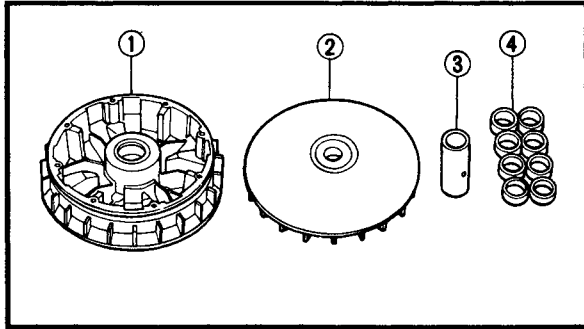

PRIMARY SHEAVE ASSEMBLY

1.Clean:

- Primary sliding sheave face ①
- Primary fixed sheave face ②
- Collar ③
- Weight ④
- Primary sliding sheave cam face

NOTE:

Remove any excess grease.

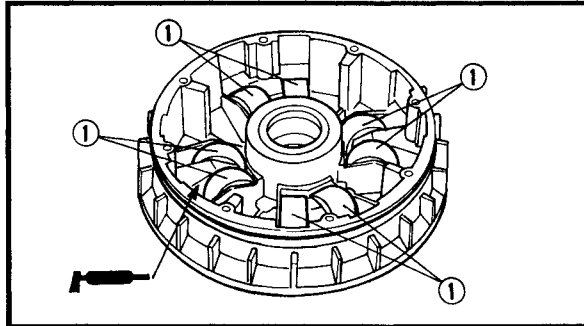

2.Install:

- Weight ①

NOTE:

- Apply Shell SSG-2656-2 grease (120 g) to the all of the outside of the weight and install.
- Apply SSG-2656-2 grease to the inside of the collar.

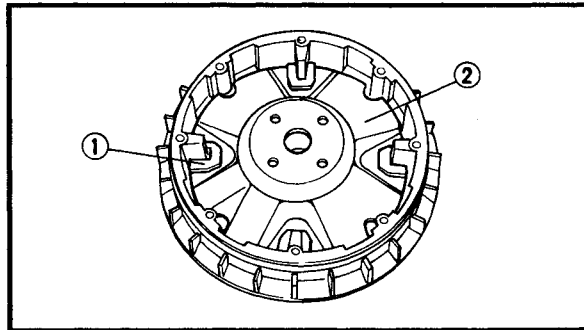

3.Install:

- Spacer
- Slider ①
- Cam ②
- Primary sliding sheave cap.

3 Nm (0.3 m · kg, 2.2 ft · lb)

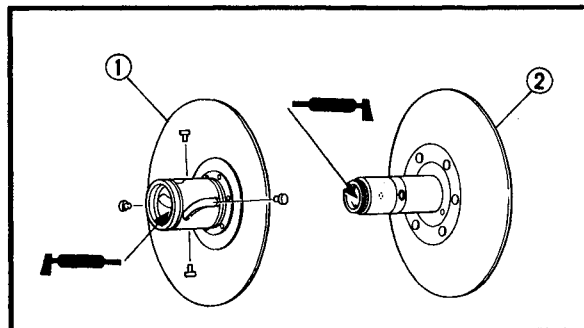

SECONDARY SHEAVE ASSEMBLY

1.Apply:

- BEL-RAY assembly lube® (to the secondary sliding sheave ① inner surface, grease nipple groove, and oil seals)
- BEL-RAY assembly lube® (to the bearings, oil seals and inner surface of the secondary fixed sheave ②)

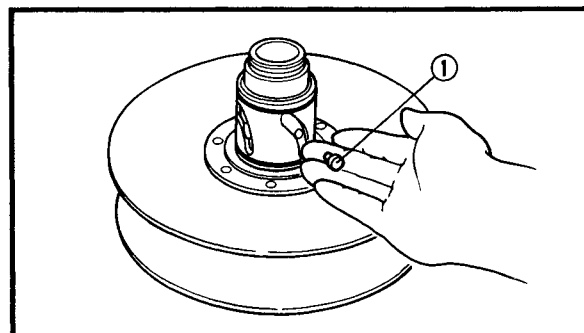

2.Install:

- Guide pin ①

PRIMARY AND SECONDARY SHEAVES

ENG

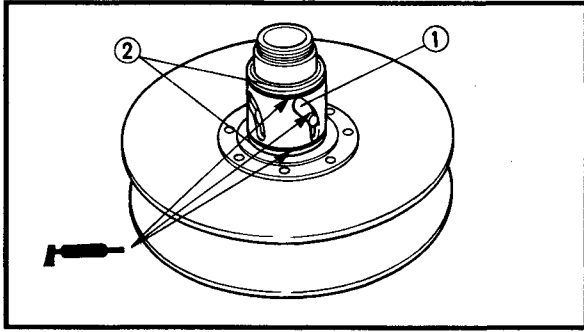

3. Apply:

- BEL-RAY assembly libe®
(to the guide pin sliding groove ①, and oil seal ② **New**)

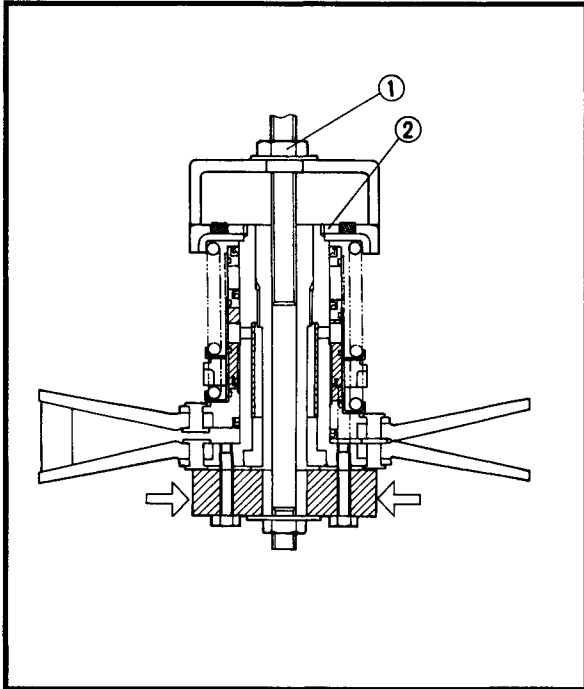

4. Install:

- Spring seat
- Compression spring
- Spring seat
- Nut

Installing steps:

- Attach the sheave fixed block, locknut wrench and sheave spring compressor to the secondary sheave assy.



Sheave fixed block:
P/N. YM-04135, 90890-04135
Locknut wrench:
P/N. 90890-01348
Sheave spring compressor:
P/N. YM-04134, 90890-04134

- Place the sheave fixed block in a vise and secure it.
- Tighten the sheave spring compressor nut ① and compress the spring.
- Install the nut ② and tighten it to the specified torque using the locknut wrench.



Nut:
90 Nm (9.0 m • kg, 65 ft • lb)

- Remove the sheave spring compressor, locknut wrench, and sheave fixed block.

5. Install:

- V-belt

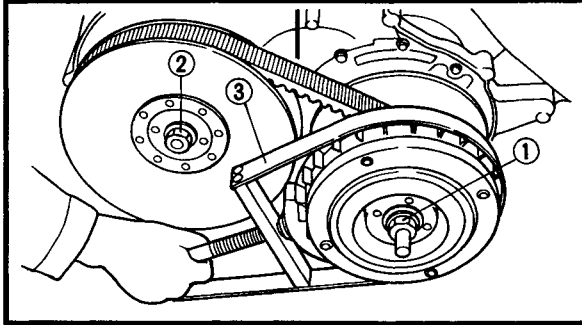

PRIMARY AND SECONDARY SHEAVES INSTALLATION

1. Install:

- Secondary sheave assembly
- V-belt
- Primary sheave assembly

2. Tighten:

- Nut (primary sheave) ①

100 Nm (10.0 m · kg, 72 ft · lb)

- Nut (secondary sheave) ②

100 Nm (10.0 m · kg, 72 ft · lb)

NOTE:

- Use the sheave holder ③ to hold the primary sheave.
- First, tighten the nut (primary sheave) ①, then tighten the nut (secondary sheave) ②.



Sheave holder:

P/N. YU-01880, 90890-01701



CLUTCH

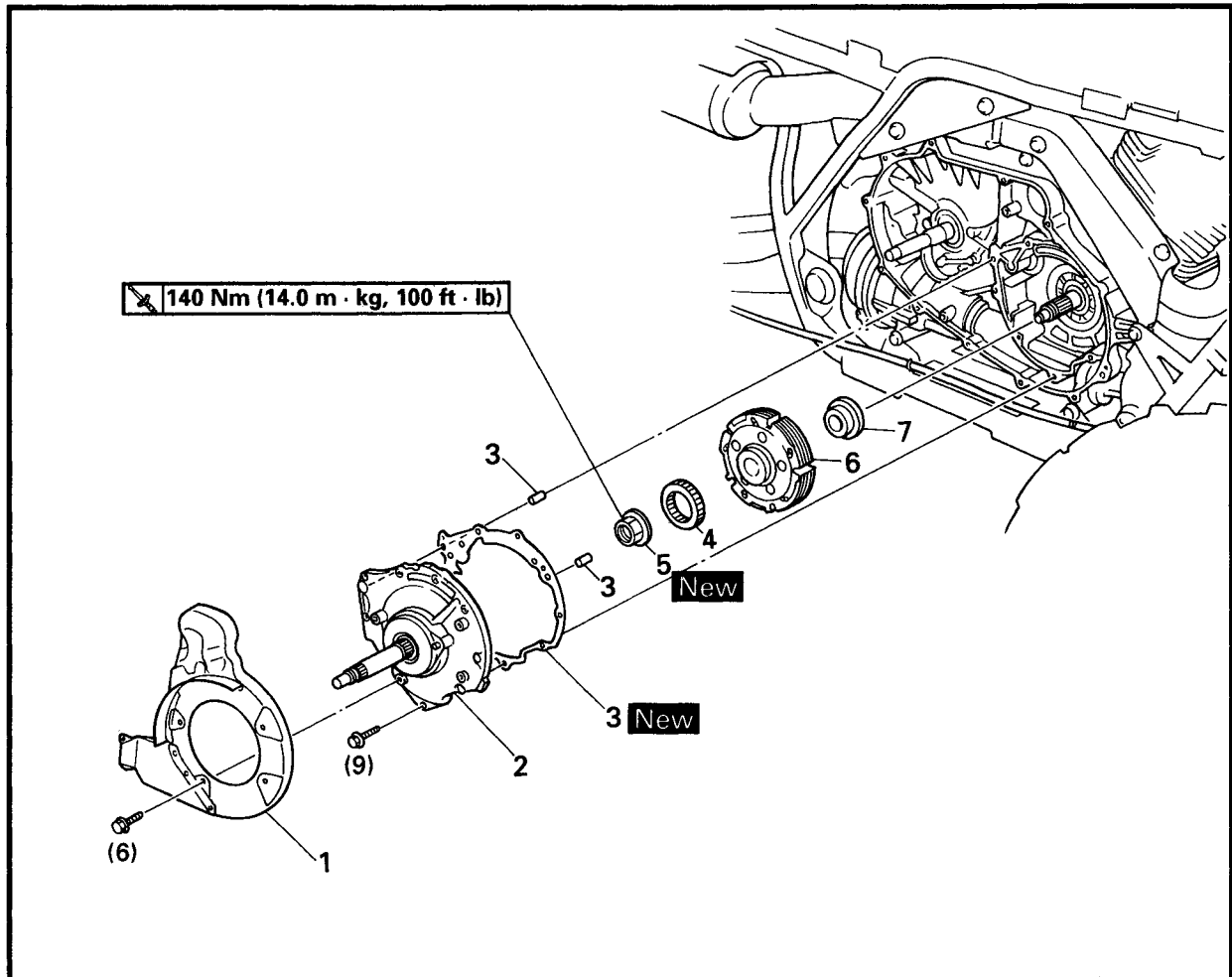

Order	Job name/Part name	Q'ty	Remarks
	Clutch removal		
	Primary and secondary sheaves		Remove the parts in the order below. Refer to "PRIMARY AND SECONDARY SHEAVES".
1	Cover	1	Refer to "CLUTCH REMOVAL / INSTALLATION".
2	Clutch housing assembly	1	
3	Gasket / dowel pin	1/2	
4	One-way clutch bearing	1	
5	Nut	1	
6	Clutch carrier assembly	1	
7	Collar	1	
			For installation, reverse the removal procedure.

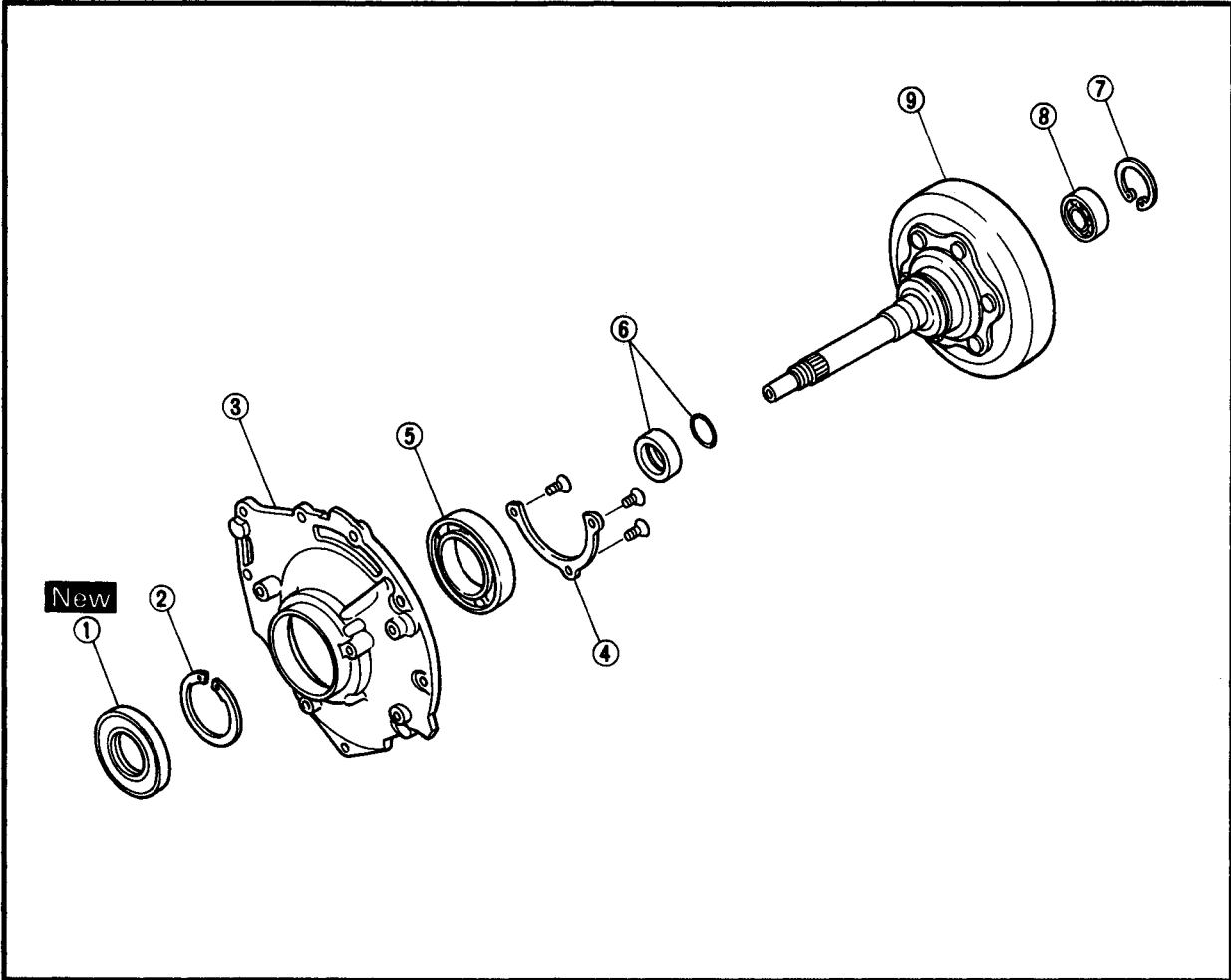

Order	Job name/Part name	Q'ty	Remarks
	Clutch housing disassembly		Disassemble the parts in the order below.
①	Oil seal	1	
②	Circlip	1	
③	Bearing housing	1	
④	Bearing retainer	1	
⑤	Bearing	1	
⑥	Collar / O-ring	1	
⑦	Circlip	1	
⑧	Bearing	1	
⑨	Clutch housing	1	
			For assembly, reverse the disassembly procedure.

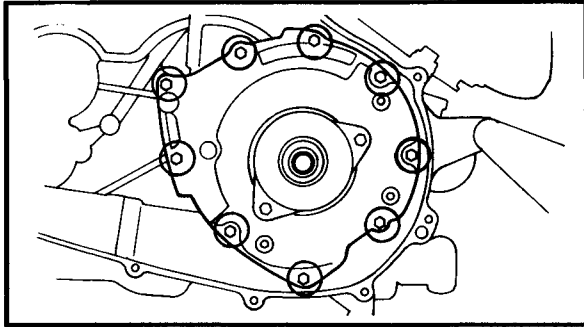

CLUTCH REMOVAL

- 1.Remove:
- Clutch housing assembly
 - Gasket
 - Dowel pins

NOTE: Working in crisscross pattern, loosen each bolt 1/4 of turn. Remove them after all of them are loosened.

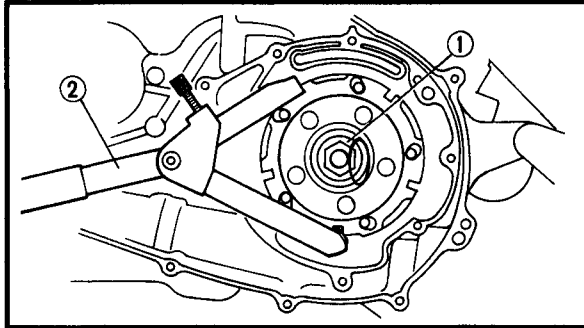

- 2.Straighten:
- Punched portion of the nut ①.
- 3.Remove:
- Nut ①

NOTE: Use a clutch holding tool ② to hold the clutch carrier assembly.



Clutch holding tool:
P/N. YM-91042, 90890-04086

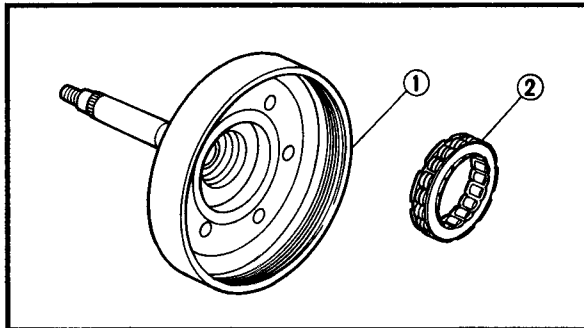

CLUTCH INSPECTION

- 1.Inspect:
- Clutch housing ①
Heat damage/wear/damage → Replace.
 - One-way clutch bearing ②
Chafing/wear/damage → Replace.

NOTE:

- Replace the one-way clutch assembly and clutch housing as a set.
- The one-way clutch bearing must be installed with the flange side facing in.

Clutch operation:

- Install the one-way clutch bearing and clutch carrier assembly to the clutch housing and hold the clutch carrier assembly.
- When turning the clutch housing clockwise [A], the clutch housing should turn freely.
If not, the one-way clutch assembly is faulty.
Replace it.
- When turning the clutch housing counter-clockwise [B], the clutch housing and crankshaft should be engaged.
If not, the one-way clutch assembly is faulty.
Replace it.

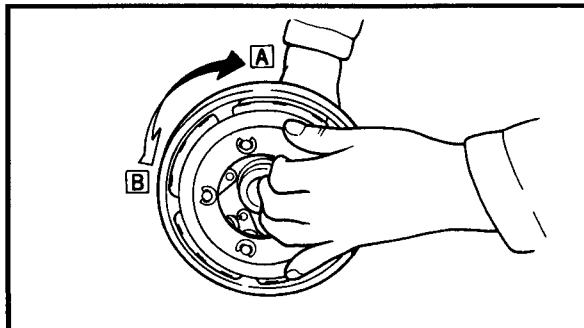

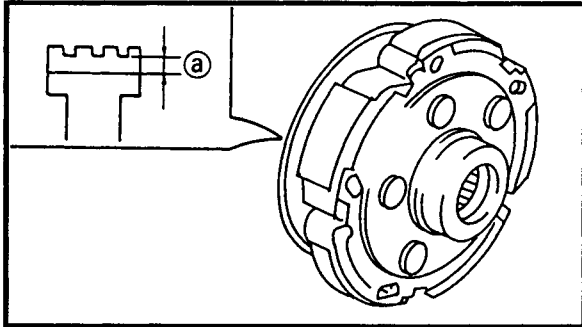

2. Inspect:

- Clutch shoe
- Heat damage → Replace.

3. Measure:

- Clutch shoe thickness
- Out of specification → Replace.



Clutch shoe thickness:

2.0 mm (0.08 in)

Clutch shoe wear limit (a):

1.5 mm (0.06 in)

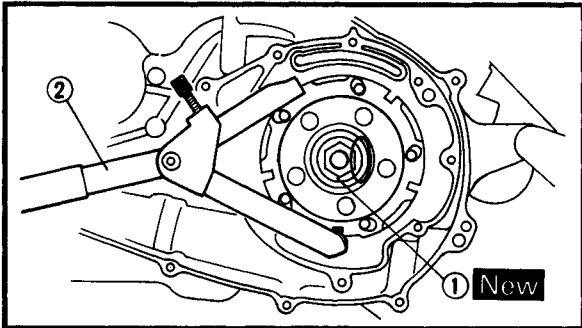

CLUTCH INSTALLATION

1. Install:

- Collar
- Clutch carrier assembly
- Nut ① **New** \times 140 Nm (14.0 m · kg, 100 ft · lb)

NOTE:

Use a clutch holding tool ② to hold the clutch carrier assembly.



Clutch holding tool:

P/N. YM-91042, 90890-04086

2. Lock the threads with a drift punch.

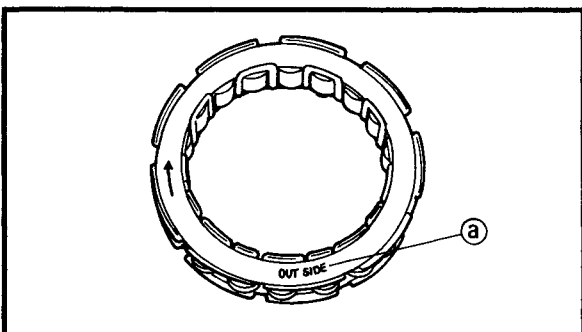

3. Install:

- One-way clutch bearing

NOTE:

The one-way clutch bearing should be installed in the clutch carrier assembly with the mark "OUT SIDE" (a) facing toward the clutch housing.

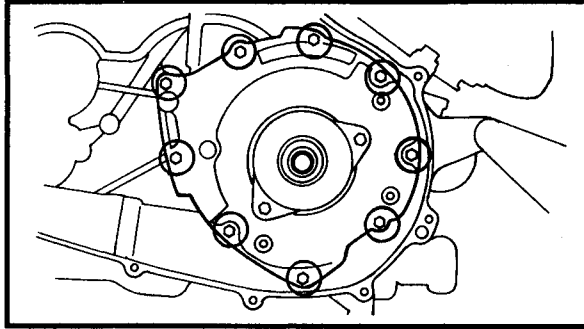
**4.Install:**

- Dowel pins
- Gasket **New**
- Clutch housing assembly

 **10 Nm (1.0 m · kg, 7.2 ft · lb)**

NOTE:

- Tighten the bolts in stages, using a criss-cross pattern.
- After tightening the bolts, check that the clutch housing assembly rotates smoothly.



CRANKCASE

STARTER MOTOR, TIMING CHAIN AND OIL FILTER

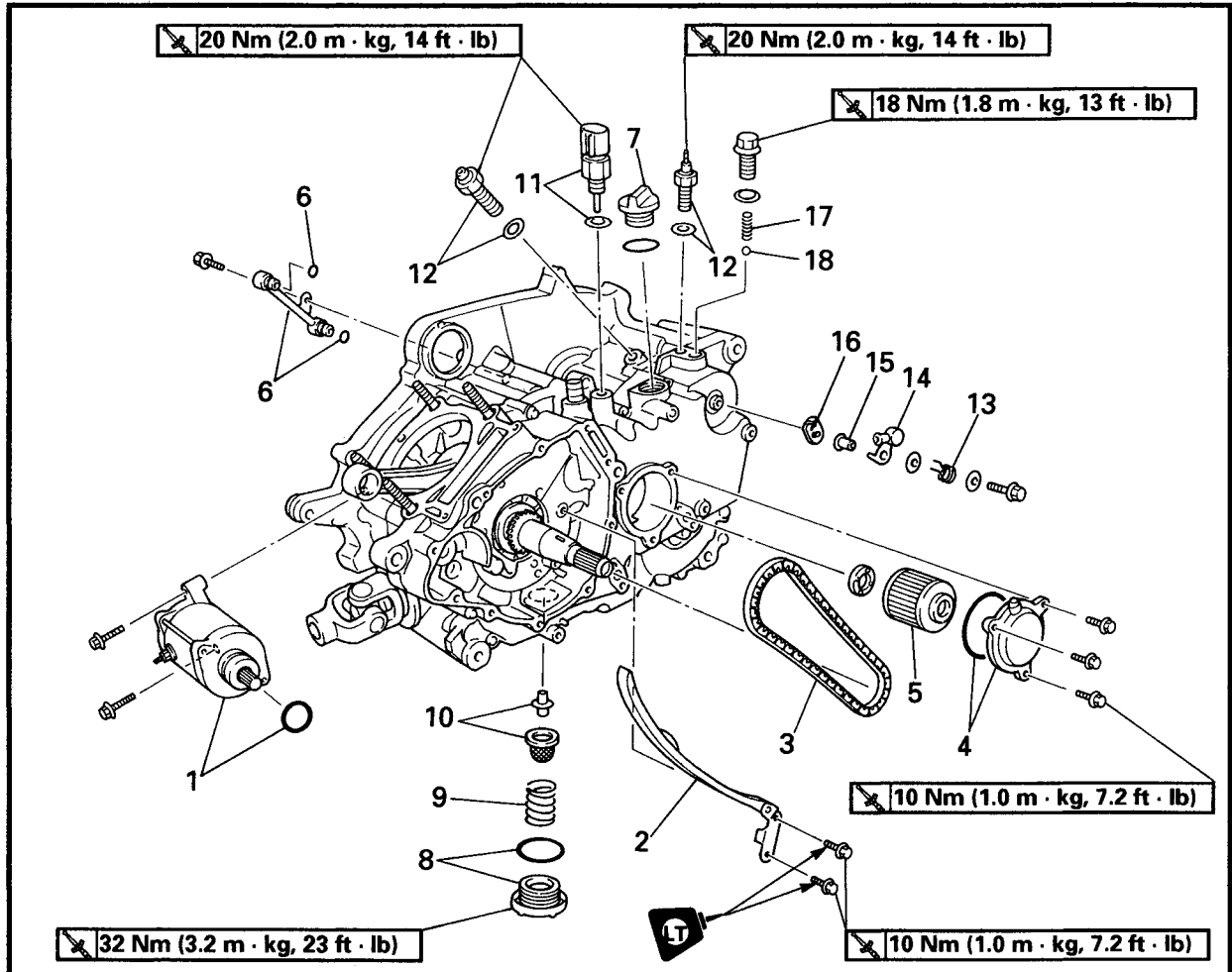

Order	Job name/Part name	Q'ty	Remarks
	Starter motor, timing chain and oil filter removal		Remove the parts in the order below.
	Engine assembly		Refer to "ENGINE REMOVAL".
	Cylinder head cover		Refer to "CYLINDER HEAD COVER".
	Cylinder head		Refer to "CAMSHAFT AND CYLINDER HEAD".
	Cylinder and piston		Refer to "CYLINDER AND PISTON".
	Recoil starter and CDI rotor		Refer to "RECOIL STARTER AND CDI MAGNETO".
	Primary and secondary sheaves		Refer to "PRIMARY AND SECONDARY SHEAVES".
	Clutch carrier assembly		Refer to "CLUTCH".
1	Starter motor / O-ring	1/1	
2	Timing chain guide (intake)	1	
3	Timing chain	1	
4	Oil filter cover / O-ring	1/1	
5	Oil filter element	1	

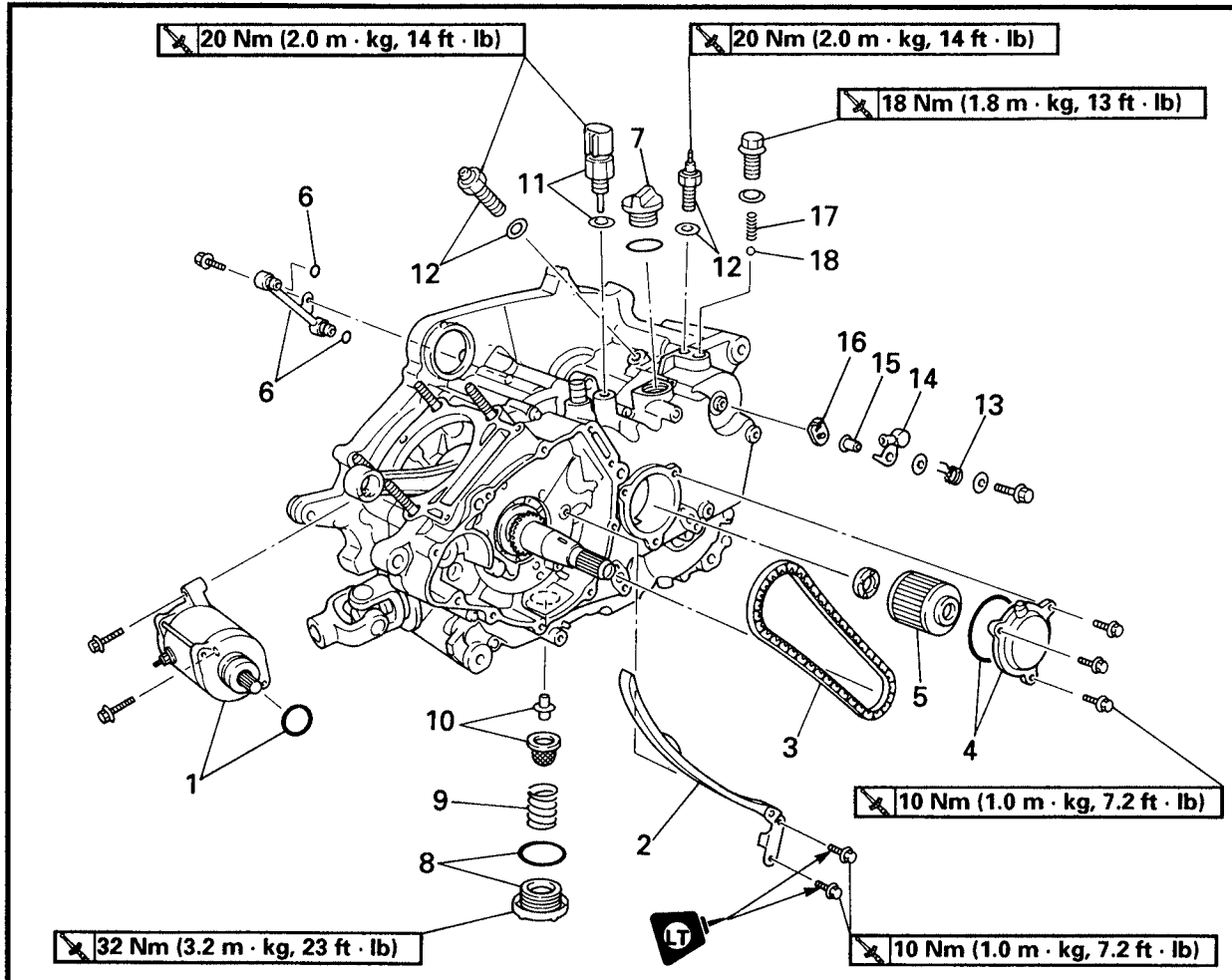

Order	Job name/Part name	Q'ty	Remarks
6	Oil delivery pipe / O-ring	1/2	
7	Oil filler plug	1	
8	Engine oil drain plug / O-ring	1	
9	Compression spring	1	
10	Oil strainer / oil supply pipe	1/1	
11	Thermo unit / copper washer	1/1	
12	Neutral / reverse switch / copper washer	1/1/2	
13	Return spring	1	
14	Lever (outside)	1	
15	Collar	1	
16	Lever (inside)	1	
17	Spring	1	
18	Ball	1	
			For installation, reverse the removal procedure.



CRANKCASE

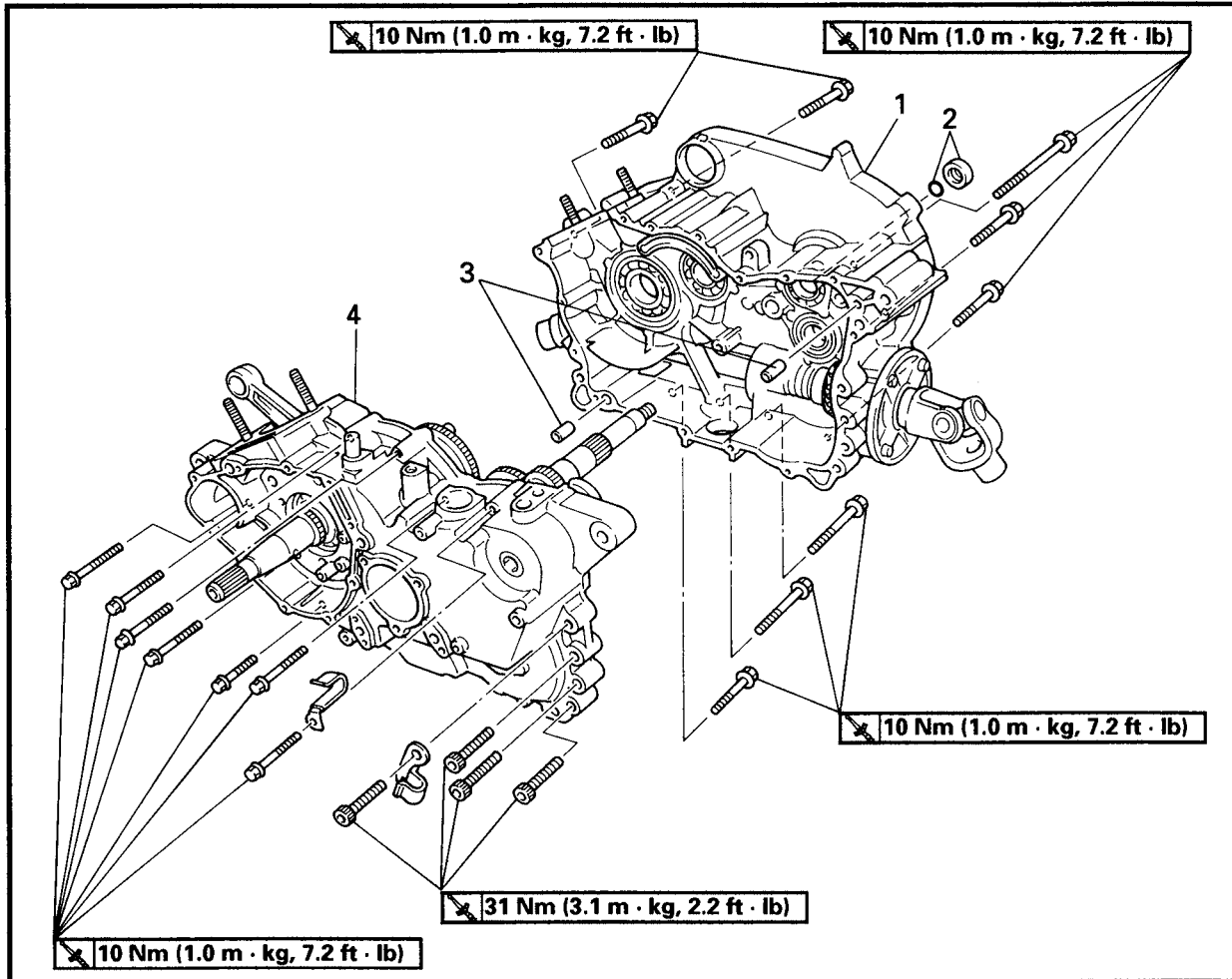

Order	Job name/Part name	Q'ty	Remarks
	Crankcase separation		Remove the parts in the order below.
1	Crankcase (right)	1	Refer to "CRANKCASE SEPARATION / ASSEMBLY".
2	Collar / O-ring	1/1	
3	Dowel pin	2	
4	Crankcase (left)	1	
			For installation, reverse the removal procedure.



CRANKCASE BEARINGS

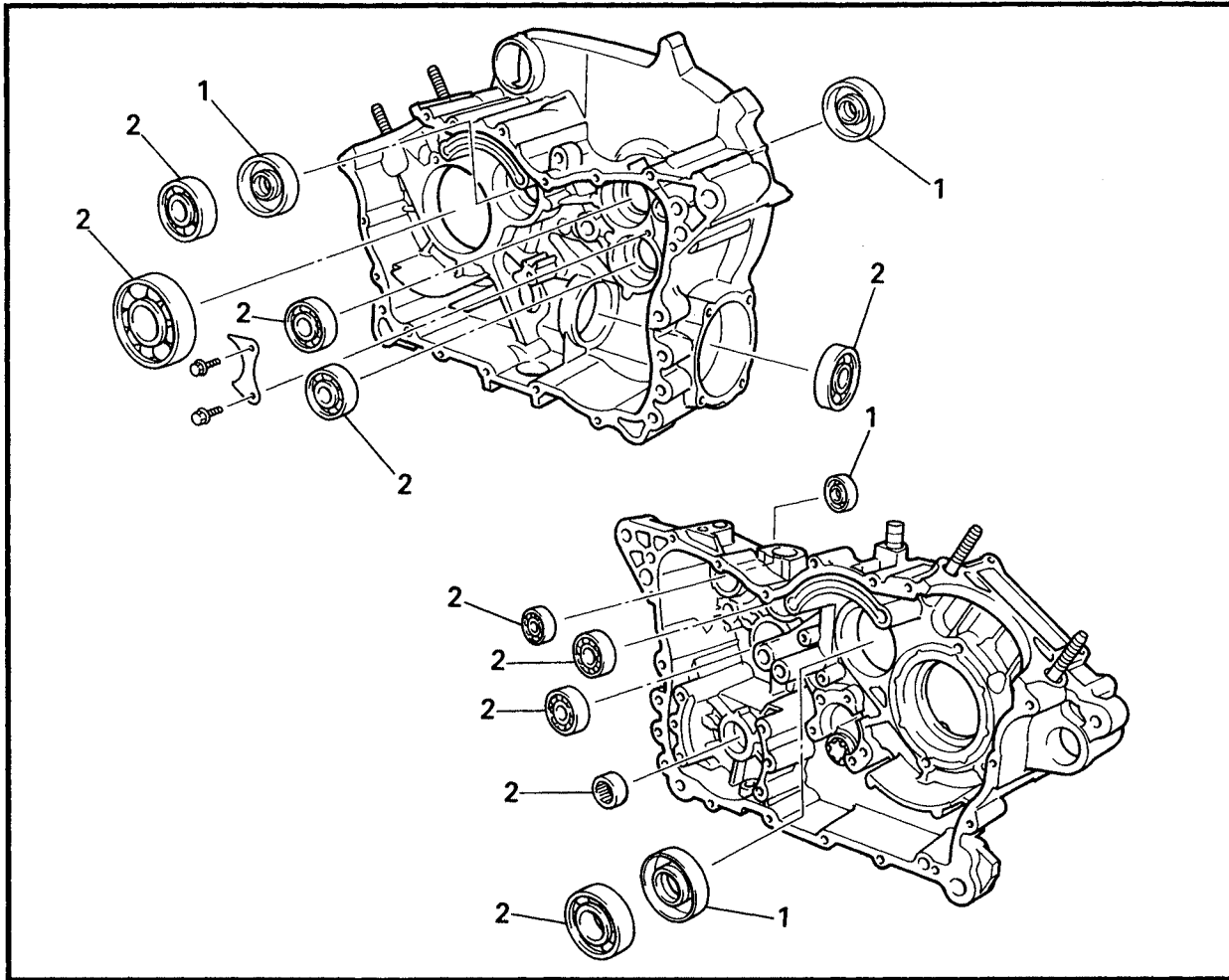

Order	Job name/Part name	Q'ty	Remarks
	Crankcase bearing removal		Remove the parts in the order below. Refer to "TRANSMISSION AND CRANKSHAFT". Refer to "OIL PUMP".
	Transmission and crankshaft		
	Middle drive shaft assembly		
	Oil pump assembly		
1	Oil seal	4	
2	Bearing	10	For installation, reverse the removal procedure.

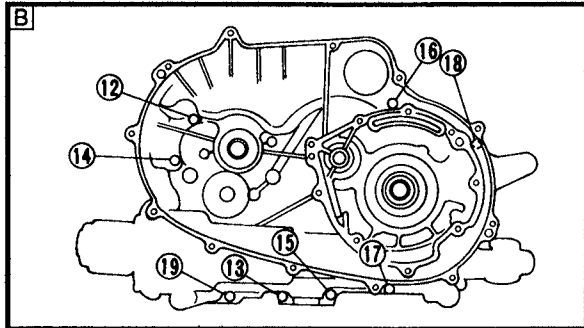
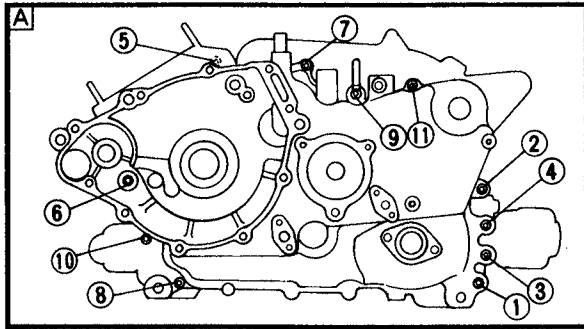

CRANKCASE SEPARATION

1. Separate:

- Right crankcase
- Left crankcase

Separation steps:

- Remove the crankcase bolts.

NOTE:

- Loosen each bolt 1/4 of a turn at a time and after all the bolts are loosened, remove them.
- Loosen the bolts in numerical order (see numbers on the illustration).

A Left crankcase

B Right crankcase

- Remove the right crankcase.

NOTE:

For this removal, slits in the crankcase.

CAUTION:

Use a soft hammer to tap on one side of the crankcase. Tap only on reinforced portions of the crankcase. Do not tap on the crankcase mating surfaces. Work slowly and carefully. Make sure that the crankcase halves separate evenly.

- Remove the collar (with O-ring).
- Remove the dowel pins.

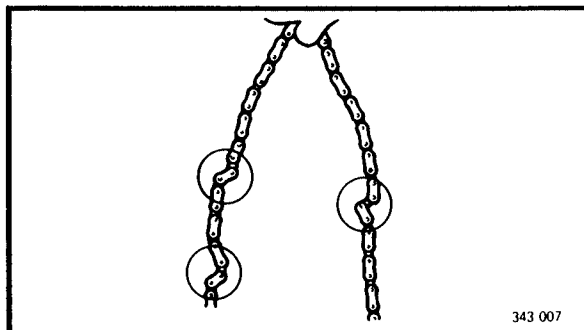

TIMING CHAIN AND GUIDE INSPECTION

1. Inspect:

- Timing chain
 - Cracks/stiff → Replace the timing chain and camshaft sprocket as a set.

2. Inspect:

- Intake side timing chain guide
 - Wear/damage → Replace.

343 007

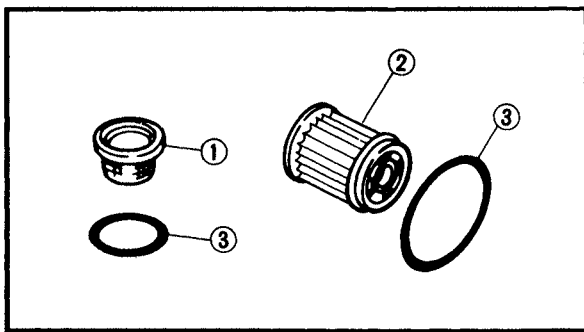

OIL STRAINER, OIL FILTER AND OIL DELIVERY PIPE INSPECTION

1. Inspect:

- Oil strainer ①
 - Oil filter ②
 - O-rings ③
- Damage → Replace.

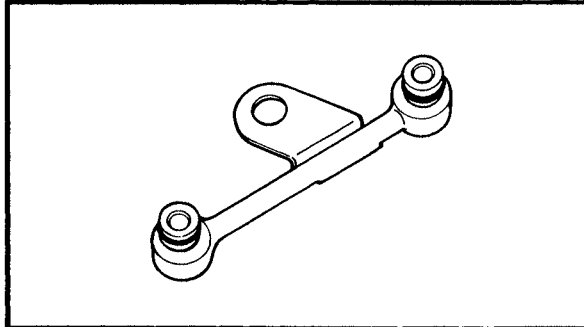

2. Inspect:

- Oil delivery pipe
- Cracks/damage → Replace.
Clogged → Blow out with compressed air.

CRANKCASE INSPECTION

1. Thoroughly wash the case halves in a mild solvent.
2. Clean all the gasket mating surfaces and crankcase mating surfaces thoroughly.
3. Inspect:
 - Crankcase

Cracks/damage → Replace.

 - Oil delivery passages

Clogged → Blow out with compressed air.

BEARINGS AND OIL SEALS INSPECTION

1. Inspect:

- Bearing
- Clean and lubricate, then rotate the inner race with a finger.
Roughness → Replace.

2. Inspect:

- Oil seals
- Damage/wear → Replace.

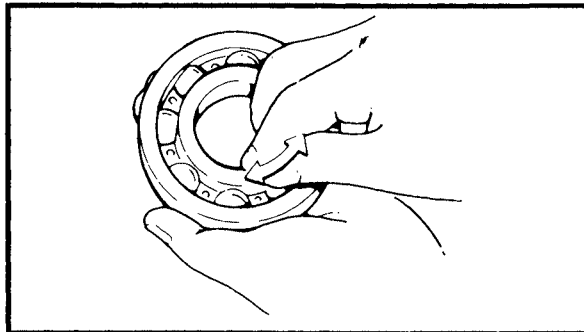

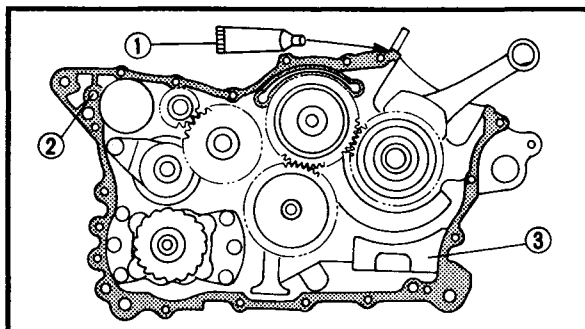

CRANKCASE ASSEMBLY

1. Apply:

- Sealant (Quick Gasket®) ①
(to the mating surfaces of both case halves)



Sealant (Quick Gasket®):
P/N. ACC-11001-05-01
Yamaha bond No. 1215:
P/N. 90890-85505

2. Install:

- Dowel pin ②
- 3. Fit the left crankcase onto the right case.
Tap lightly on the case with a soft hammer.

CAUTION:

- Before installing and torquing the crankcase holding bolts, be sure to check whether the transmission is functioning properly by manually rotating the shift cam in both directions.
- Be sure to install the rubber damper ③ in order to enable proper oil flow through the engine and avoid engine damage.

4. Tighten:

- Crankcase bolts
(follow the proper tightening sequence)

NOTE:

Install the clamp on the bolt ⑨, ⑱.

① ~ ⑮ (M6)	10 Nm (1.0 m · kg, 7.2 ft · lb)
⑯ ~ ⑲ (M8)	31 Nm (3.1 m · kg, 22 ft · lb)

- Ⓐ Right crankcase
- Ⓑ Left crankcase

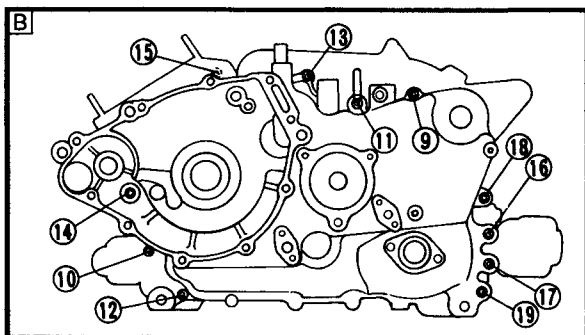
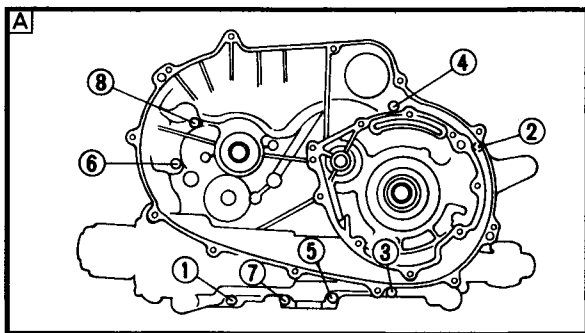

M6 × 35 mm	⑫
M6 × 40 mm	① ② ③ ⑥ ⑧
M6 × 55 mm	⑨ ⑩ ⑪ ⑬ ⑭ ⑮
M6 × 60 mm	⑤ ⑦
M6 × 90 mm	④
M8 × 50 mm	⑯ ⑰ ⑱

5. Apply:

- 4-stroke engine oil
(to the crank pin, bearing and oil delivery hole)

6. Check:

- Crankshaft and transmission operation
Unsmooth operation → Repair.

TRANSMISSION AND CRANKSHAFT

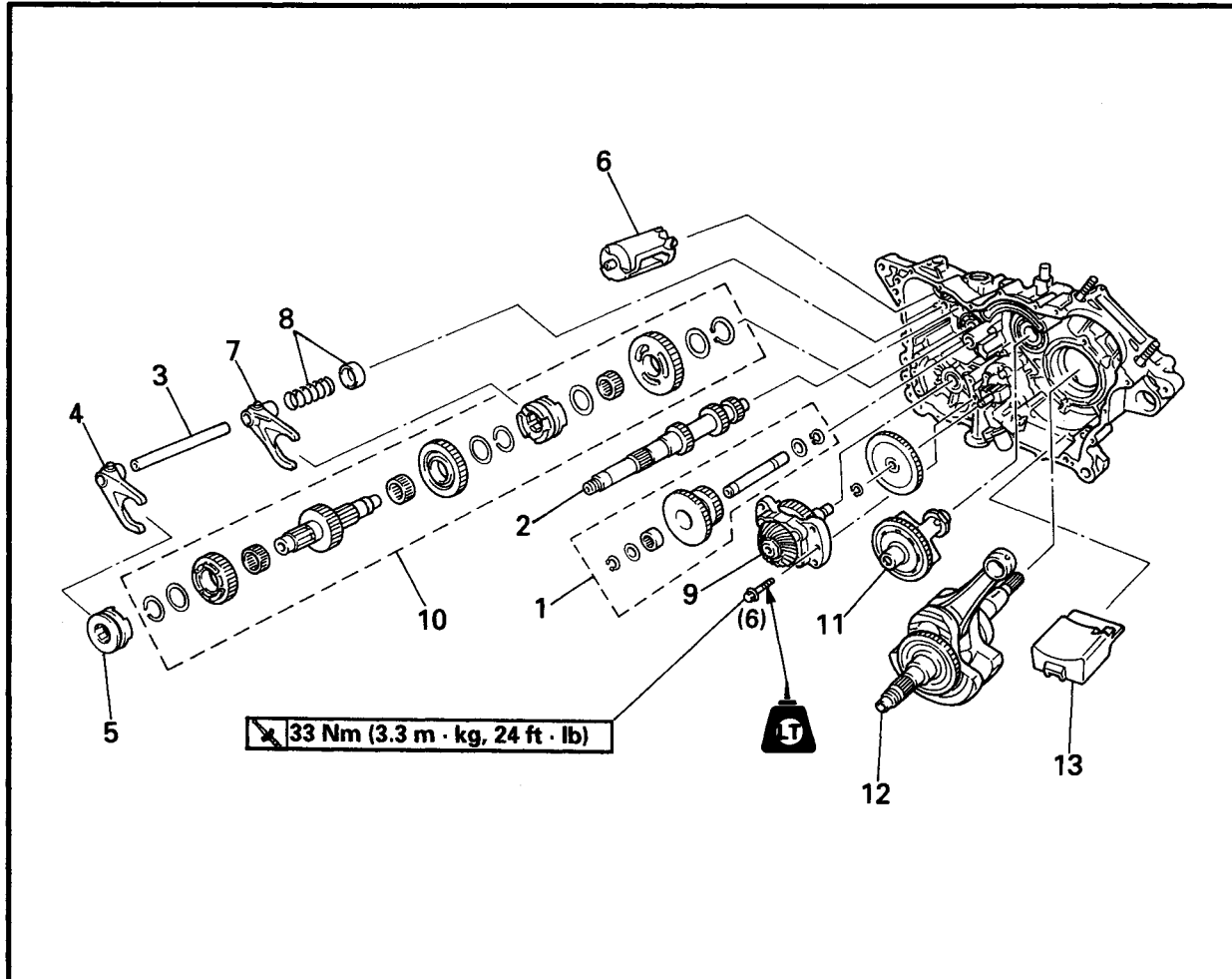

Order	Job name/Part name	Q'ty	Remarks
	Transmission and crankshaft removal		Remove the parts in the order below.
	Crankcase separation		Refer to "CRANKCASE".
1	Idle gear	1	Refer to "TRANSMISSION INSTALLATION".
2	Secondary shaft	1	
3	Guide bar	1	
4	Shift fork "R"	1	
5	Clutch dog 2	1	
6	Shift cam	1	
7	Shift fork "L"	1	
8	Spring / spring cap	1/1	
9	Middle drive shaft assembly	1	
10	Dive axle assembly	1	
11	Balancer	1	Refer to "CRANKSHAFT REMOVAL / CRANKSHAFT AND BALANCER INSTALLATION".
12	Crankshaft	1	
13	Rubber damper	1	
			For installation, reverse the removal procedure.

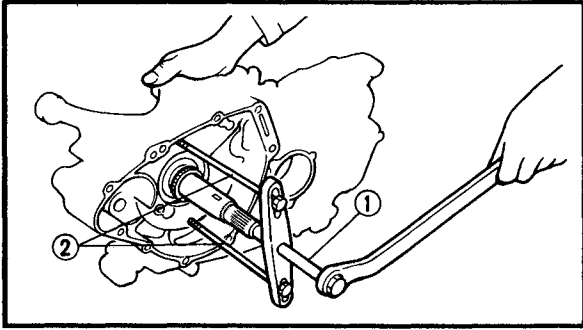

CRANKSHAFT REMOVAL

1.Remove:

- Crankshaft

Use a crankcase separating tool ① and slide hammer bolt ②.



Crankcase separating tool:
P/N. YU-01135-A, 90890-01135
Slide hammer bolt (M8):
P/N. YU-01083-2, 90890-01085

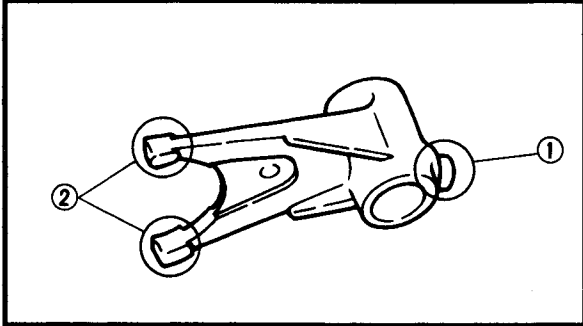

SHIFT FORK INSPECTION

1.Inspect:

- Shift fork cam follower ①
- Shift fork pawl ②

Scoring/bends/wear/damage → Replace.

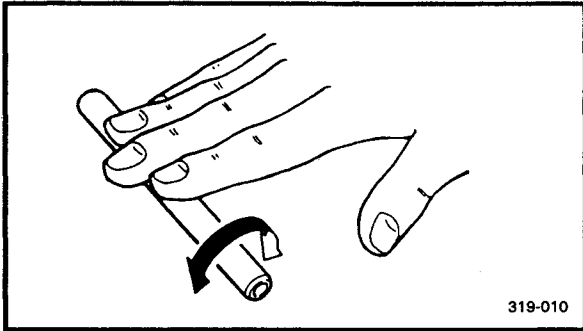

2.Inspect:

- Guide bar

Roll the guide bar on a flat surface.

Bends → Replace.

⚠ WARNING

Do not attempt to straighten a bent guide bar.

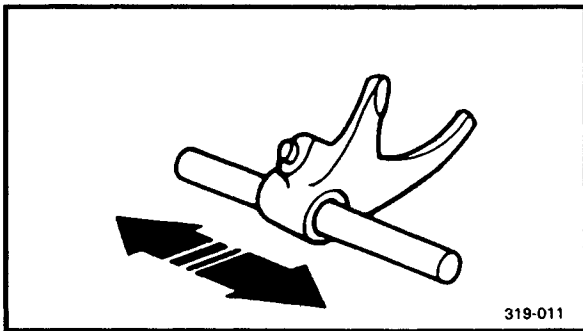

3.Check:

- Shift fork movement (on the guide bar)

Unsmooth operation → Replace the shift fork and the guide bar.

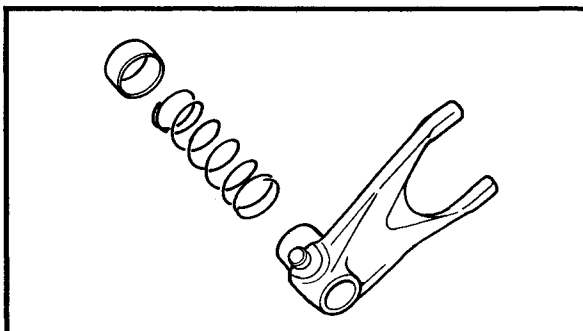

4.Inspect:

- Spring cap
- Spring

Cracks/damage → Replace.

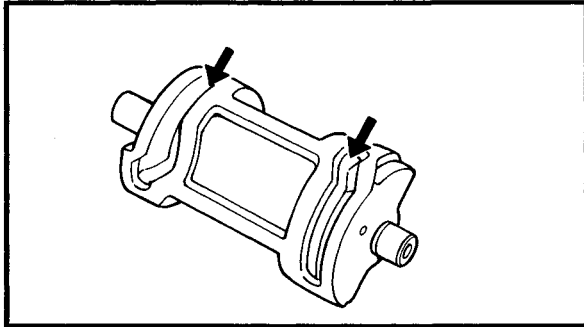

SHIFT CAM INSPECTION

1. Inspect:

- Shift cam grooves
Scratches/wear/damage → Replace.

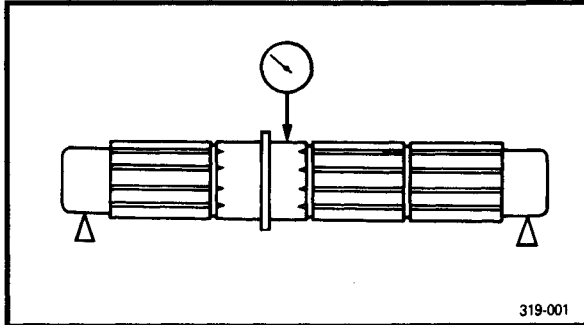

TRANSMISSION INSPECTION

1. Measure:

- Axle runout
Use a centering device and a dial gauge.
Out of specification → Replace the bent axle.



**Runout limit (drive axle):
0.03 mm (0.001 in)**

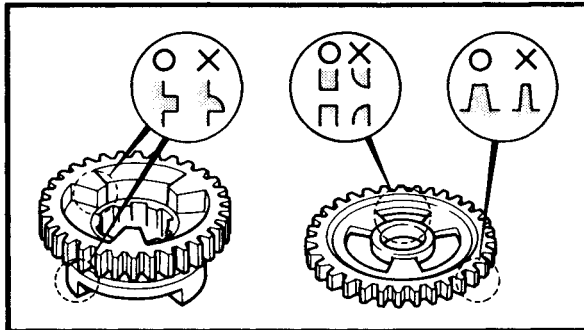

2. Inspect:

- Gear teeth
Blue discoloration/pitting/wear → Replace.
- Mated dogs
Rounded edges/cracks/missing portions → Replace.

3. Check:

- Gear movement
Unsmooth → Repeat steps #1 and #2 or replace the defective parts.

4. Inspect:

- Circlip
Bends/looseness/damage → Replace.

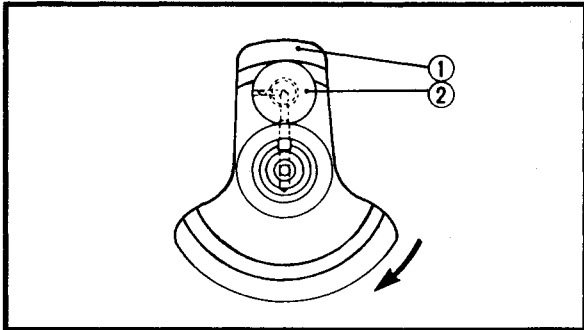
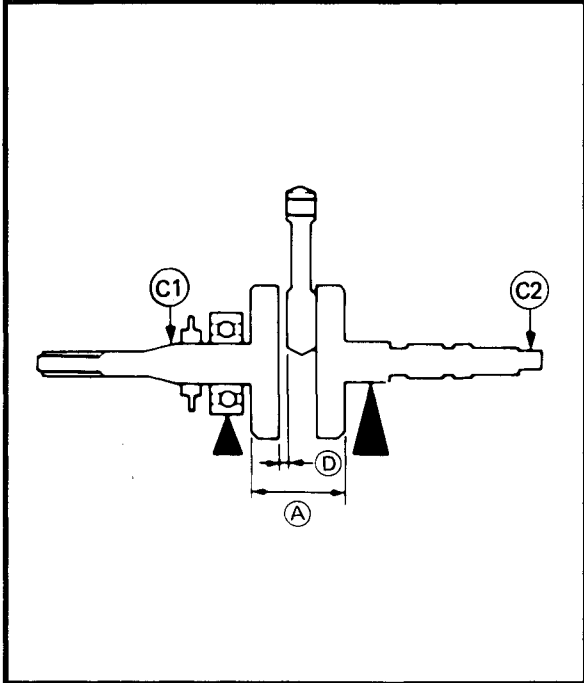

CRANKSHAFT INSPECTION

1. Measure:

- Crank width (A)

Out of specification → Replace the crankshaft.

	Crank width:
	74.95 ~ 75.00 mm
	(2.951 ~ 2.953 in)

- Side clearance (D)

Out of specification → Replace the crankshaft.

	Big end side clearance:
	0.35 ~ 0.65 mm (0.014 ~ 0.026 in)
	<Limit: 1.0 mm (0.040 in)>

- Runout (C)

Out of specification → Replace the crankshaft.

	Runout limit:
	C1: 0.03 mm (0.0012 in)
	C2: 0.03 mm (0.0012 in)

Crankshaft reassembling point:

The crankshaft ① and the crank pin ② oil passages must be properly interconnected with a tolerance of less than 1 mm (0.04 in).

CAUTION:

The buffer boss and woodruff key should be replaced when removed from the crankshaft.

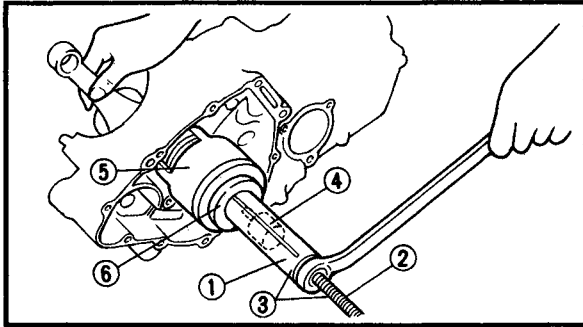

CRANKSHAFT AND BALANCER INSTALLATION

1. Install:

- Crankshaft



Crankshaft installer pot ①:
P/N. 90890-01274
Crankshaft installer bolt ②:
P/N. 90890-01275
Crankshaft installer set ③:
P/N. YU-90050
Adapter #12 ④:
P/N. YM-01383, 90890-01383
Crank pot spacer ⑤:
P/N. YM-91044, 90890-04081
Spacer ⑥:
P/N. 90890-01016

NOTE:

Hold the connecting rod at Top Dead Center (TDC) with one hand while turning the nut of the installing tool with the other. Operate the installing tool until the crankshaft bottoms against the bearing.

CAUTION:

Apply engine oil to each bearing to protect the crankshaft against scratches and to make installation easier.

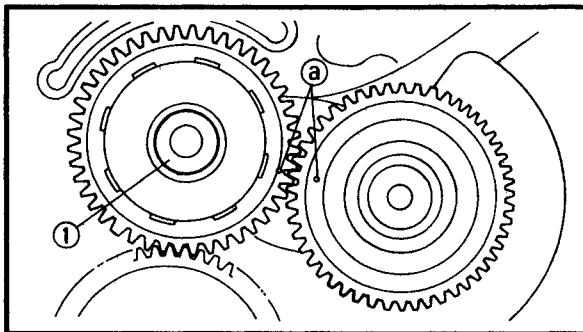

2. Install:

- Balancer ①

NOTE:

Align the punch marks ① on the drive and driven gear.

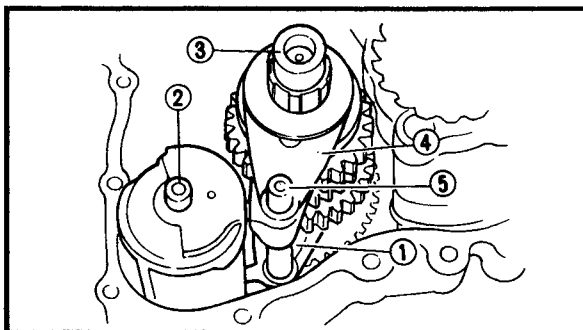

TRANSMISSION INSTALLATION

1. Install:

- Spring cap
- Spring
- Shift fork "L" ①
- Shift cam ②
- Clutch dog 2 ③
- Shift fork "R" ④
- Guide bar ⑤

**NOTE:**

The number stamped into the shift fork must always face towards the right side of the crankcase. Be sure that the shift fork guide pin is properly seated in the shift drum groove.

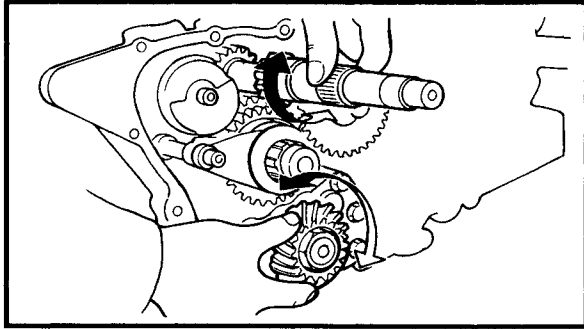
**2.Check:**

- Shift operation
Unsmooth operation → Repair.

NOTE:

- Oil each gear and bearing thoroughly.
- Before assembling the crankcase, be sure that the transmission is in neutral and that the gears turn freely.



OIL PUMP

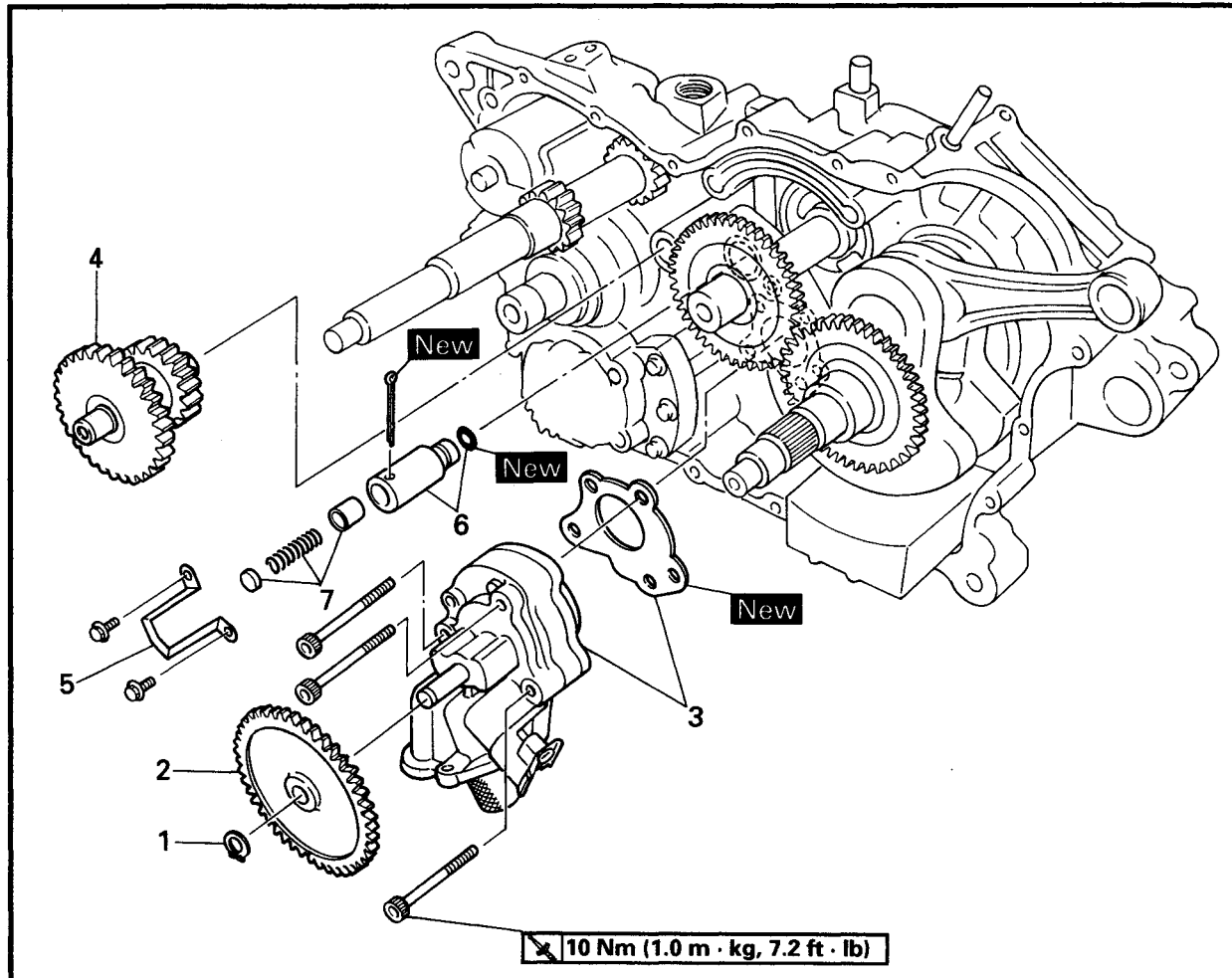

Order	Job name/Part name	Q'ty	Remarks
	Oil pump removal		Remove the parts in the order below. Refer to "CRANKCASE".
	Crankcase separation		
1	Circlip	1	
2	Oil pump driven gear	1	
3	Oil pump assembly / gasket	1/1	
4	Idle gear	1	
5	Holder	1	
6	Relief valve / O-ring	1/1	
7	Spring cap / spring seat	1/1/1	
			For installation, reverse the removal procedure.

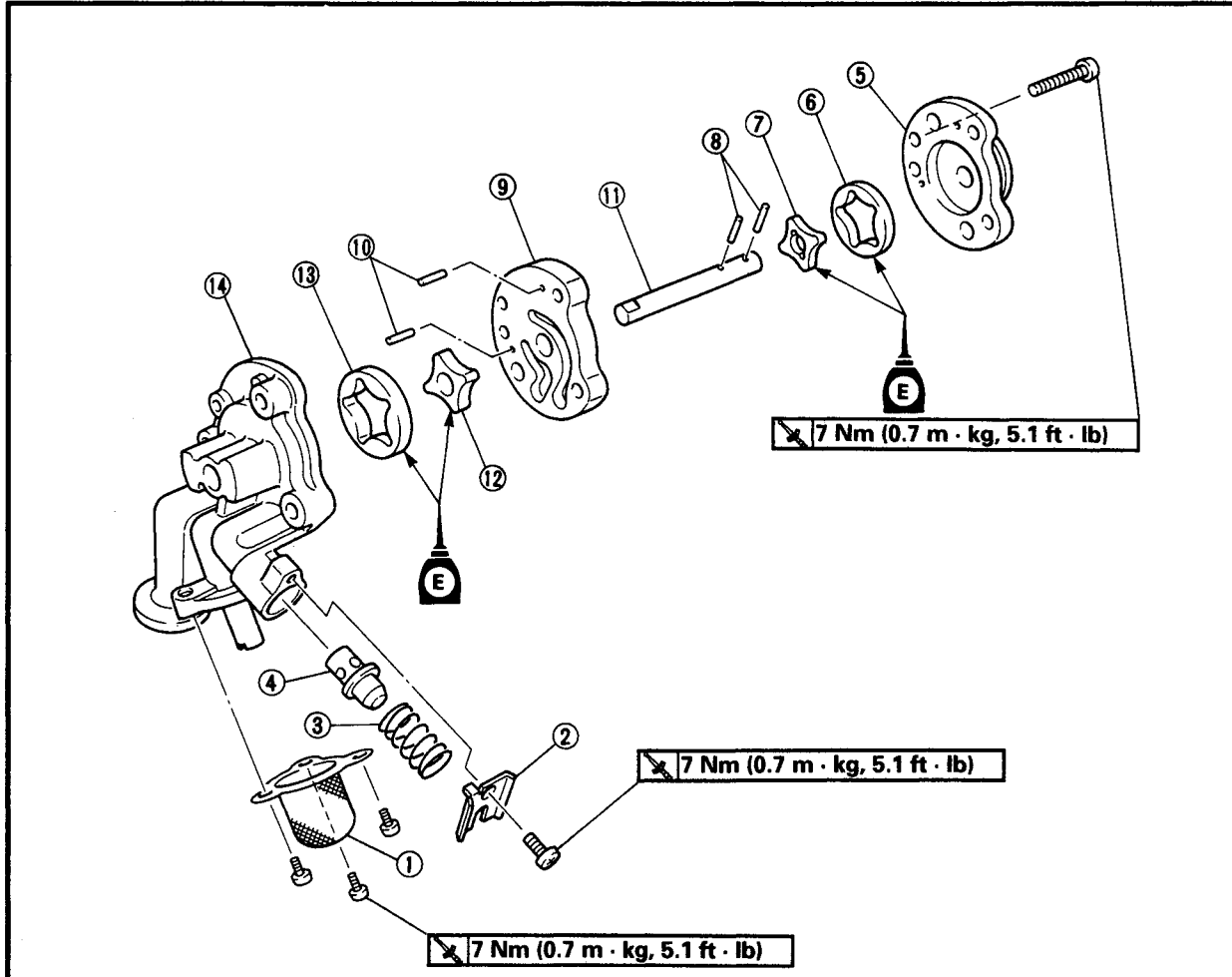

Order	Job name/Part name	Q'ty	Remarks
	Oil pump disassembly		Disassemble the parts in the order below.
①	Oil strainer	1	
②	Spring retainer	1	
③	Spring	1	
④	Relief valve	1	
⑤	Rotor housing 1	1	
⑥	Inner rotor 1	1	
⑦	Outer rotor 1	1	
⑧	Dowel pin	2	
⑨	Pump cover	1	
⑩	Dowel pin	2	
⑪	Shaft	1	

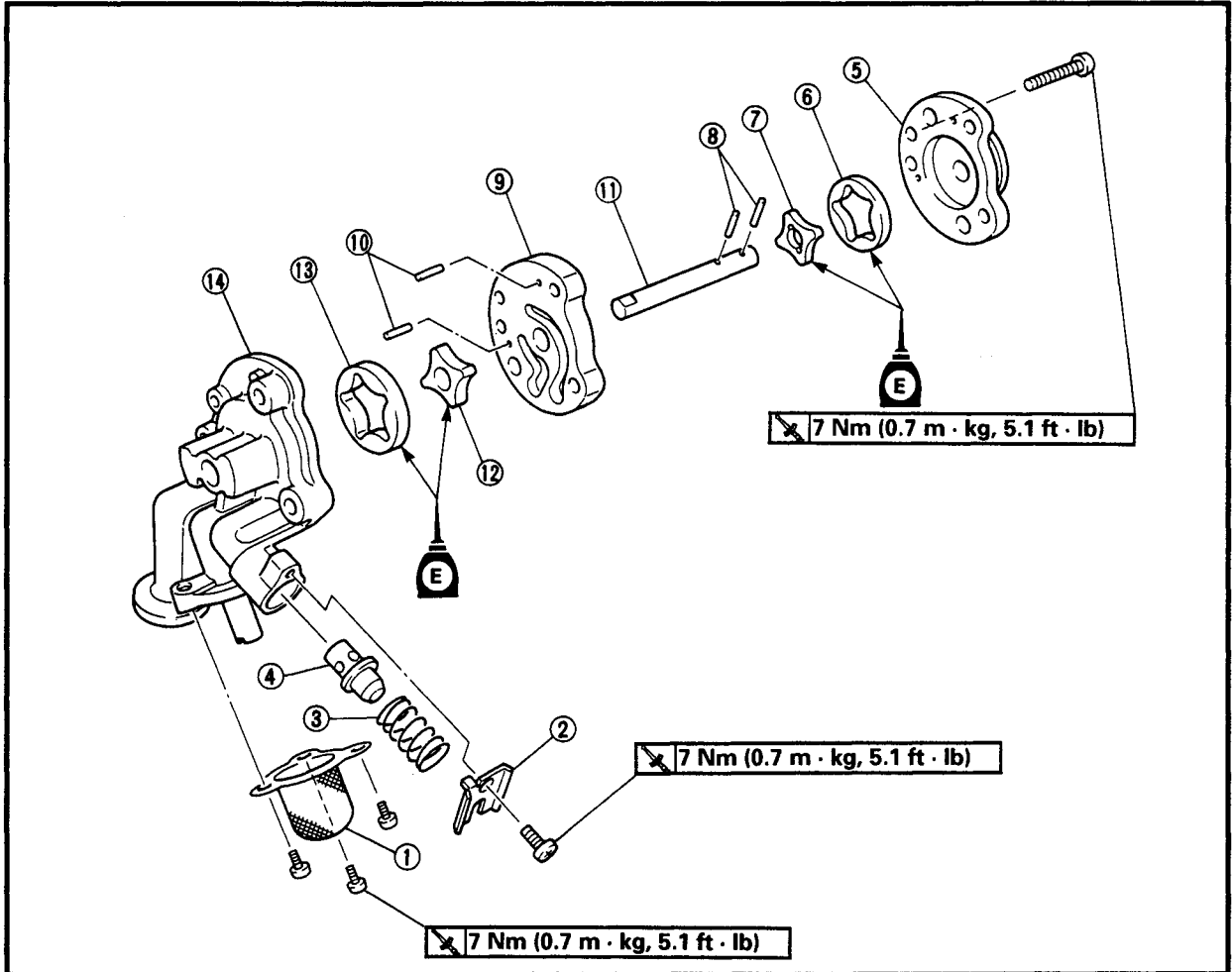

Order	Job name/Part name	Q'ty	Remarks
⑫	Inner rotor 2	1	For assembly, reverse the disassembly procedure.
⑬	Outer rotor 2	1	
⑭	Rotor housing 2	1	

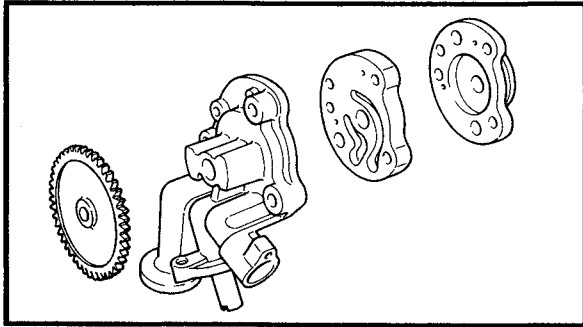

OIL PUMP INSPECTION

1. Inspect:
- Oil pump driven gear
 - Rotor housings
 - Rotor cover
- Cracks / wear / Damage → Replace.

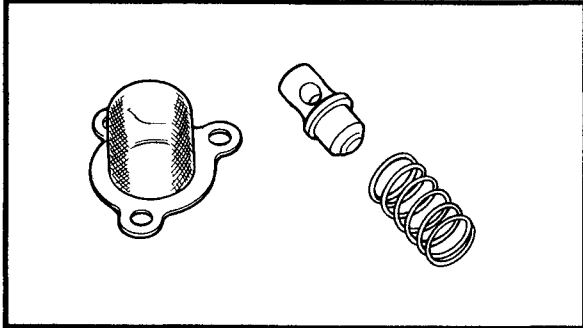

2. Clean:
- Oil strainer
3. Inspect:
- Oil strainer
 - Relief valve
 - Spring
- Damage → Replace.

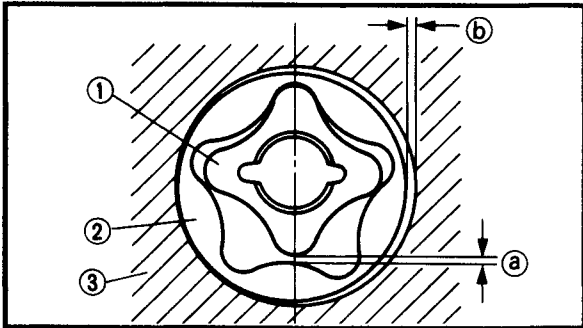

4. Measure:
- Tip clearance **a**
(between the inner rotor ① and the outer rotor ②)
 - Side clearance **b**
(between the outer rotor ② and the pump housing ③)
- Out of specification → Replace the oil pump.



Tip clearance **a:**
 0.12 mm (0.005 in)
 <Limit: 0.2 mm (0.008 in)>

Side clearance **b:**
 0.09 ~ 0.15 mm (0.004 ~ 0.006 in)
 <Limit: 0.22 mm (0.009 in)>

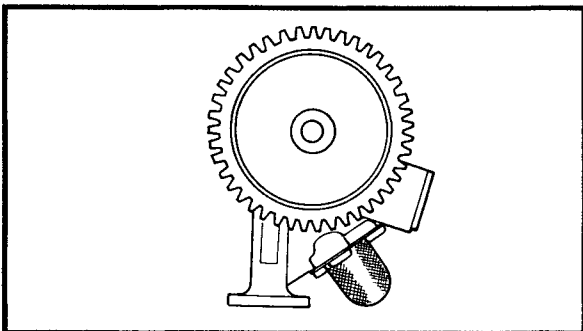

5. Check:
- Unsmooth → Repeat steps #1 and #3 or replace the defective parts.

MIDDLE GEAR
MIDDLE DRIVE SHAFT

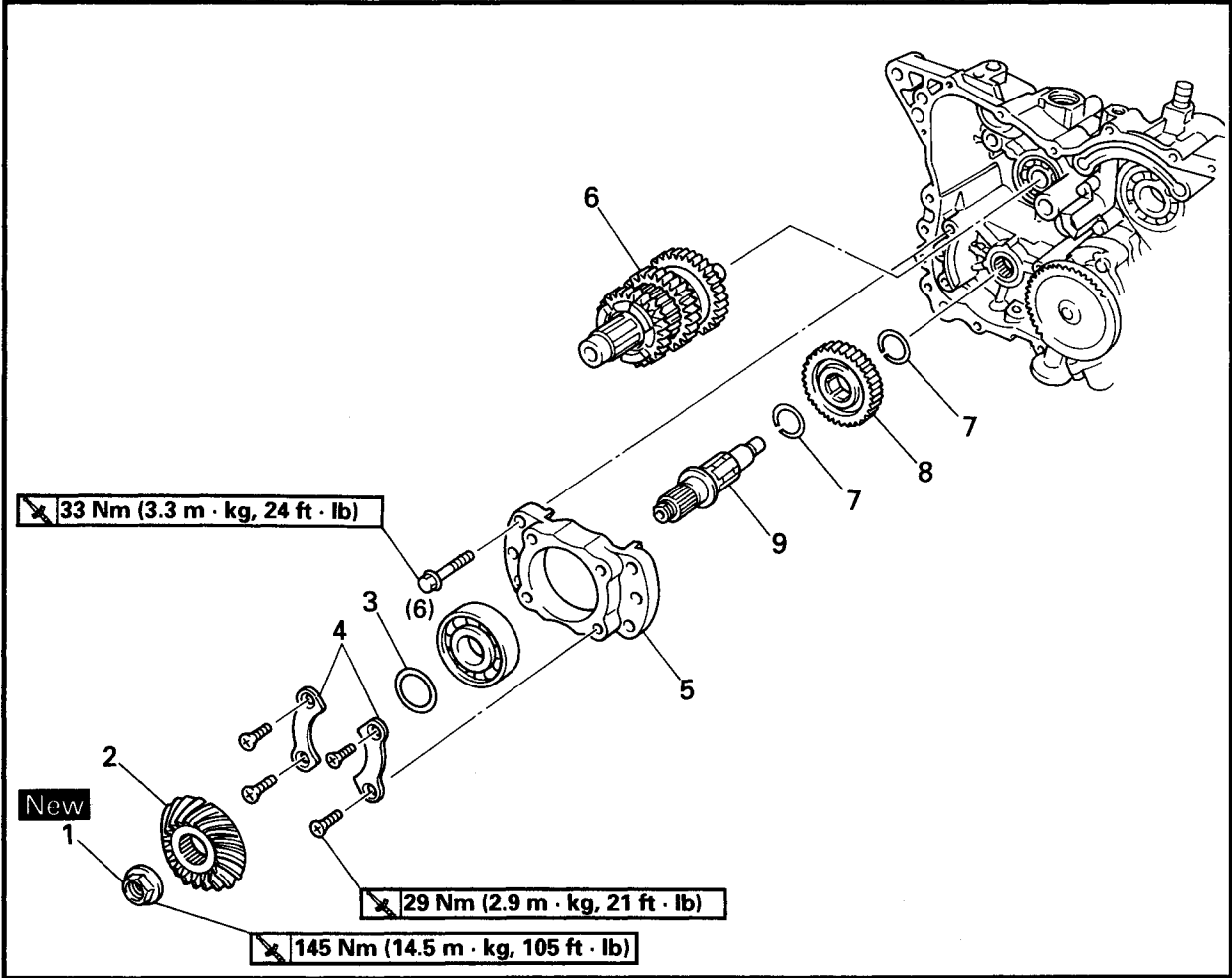

Order	Job name/Part name	Q'ty	Remarks
	Middle drive shaft removal		Remove the parts in the order below.
	Crankcase separation		Refer to "CRANKCASE".
	Shift fork		Refer to "TRANSMISSION AND CRANKSHAFT".
1	Nut	1	Refer to "MIDDLE DRIVE SHAFT REMOVAL / INSTALLATION".
2	Middle drive pinion gear	1	
3	Shim		Refer to "MIDDLE DRIVE AND DRIVEN GEAR SHIM SELECTION".
4	Bearing retainer	2	
5	Bearing housing	1	
6	Drive axle assembly	1	
7	Circlip	2	
8	Drive gear (middle drive shaft)	1	
9	Middle drive shaft	1	
			For installation, reverse the removal procedure.



MIDDLE DRIVEN SHAFT

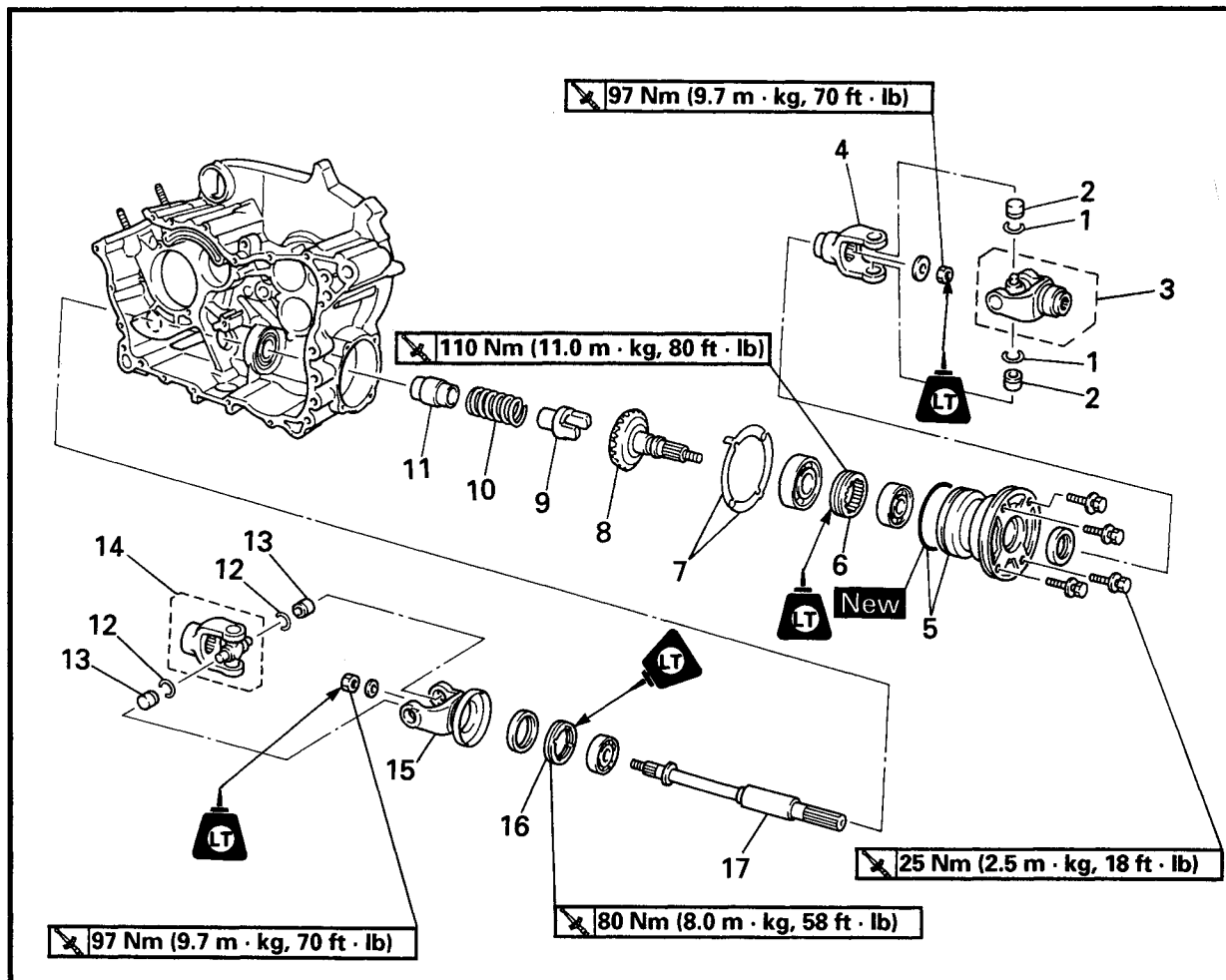

Order	Job name/Part name	Q'ty	Remarks
	Middle driven shaft assembly		
	Crankcase separation		Remove the parts in the order below. Refer to "CRANKCASE".
1	Circlip	2	Refer to "MIDDLE DRIVEN SHAFT REMOVAL / INSTALLATION".
2	Bearing	2	
3	Universal joint	1	
4	Universal joint yoke	1	
5	Bearing housing / O-ring	1/1	
6	Bearing retainer	1	Refer to "MIDDLE DRIVE AND DRIVEN GEAR SHIM SELECTION".
7	Shim		
8	Middle drive pinion gear	1	
9	Damper cam	1	
10	Spring	1	
11	Gear coupling	1	

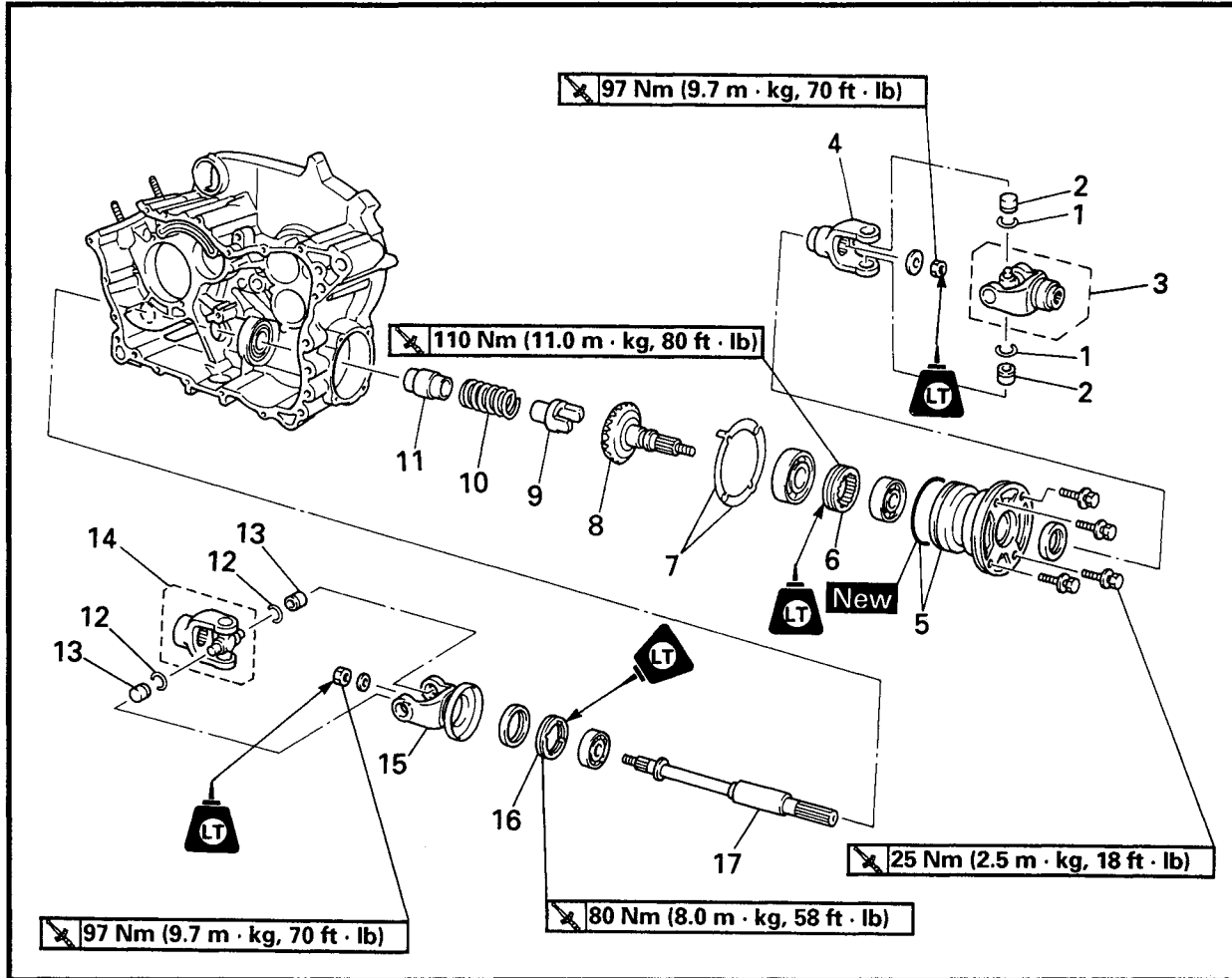

Order	Job name/Part name	Q'ty	Remarks
12	Circlip	2	Refer to "MIDDLE DRIVE SHAFT REMOVAL / INSTALLATION".
13	Bearing	2	
14	Universal joint	1	
15	Universal joint yoke	1	
16	Bearing retainer	1	
17	Middle driven shaft	1	
			For installation, reverse the removal procedure.

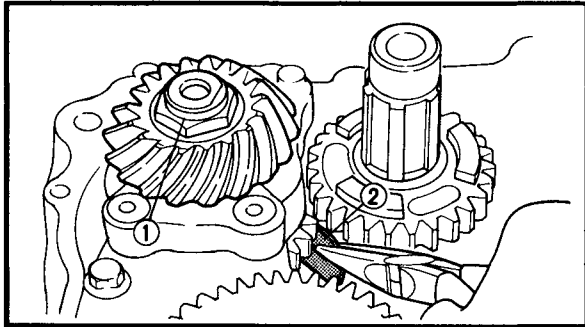

MIDDLE DRIVE SHAFT REMOVAL

1. Straighten:

- Punched portion of the nut (middle drive pinion gear)

2. Loosen:

- Nut (middle drive pinion gear) ①

NOTE:

Place a copper plate ② between the teeth of the drive gear and the driven gear to lock them.

3. Remove:

- Nut (middle drive pinion gear)
- Middle drive pinion gear
- Shim(s)

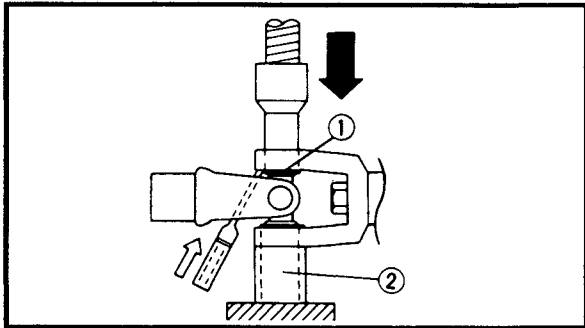

MIDDLE DRIVEN SHAFT REMOVAL

1. Remove:

- Universal joint

Universal joint removal steps:

- Remove the circlips ①.
- Place the U-joint in a press.
- With a suitable diameter pipe ② beneath the yoke ③, press the bearing ④ into the pipe as shown.

NOTE:

It may be necessary to lightly tap the yoke with a punch.

- Repeat the steps for the opposite bearing.
- Remove the yoke.

NOTE:

It may be necessary to lightly tap the yoke with a punch.

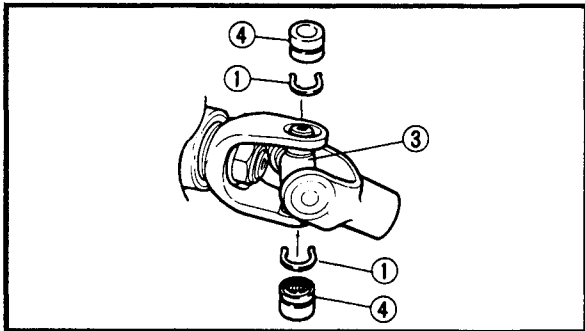

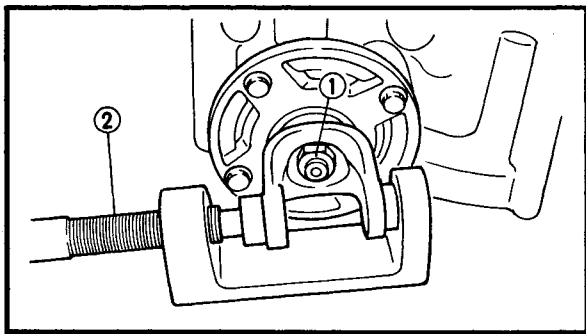

- 2.Remove:
- Nut ①
 - Washer
 - Universal joint yoke (rear side)

NOTE: _____
Use the universal joint holder ② to hold the universal joint yoke.



Universal joint holder:
P/N. YM-04062, 90890-04062

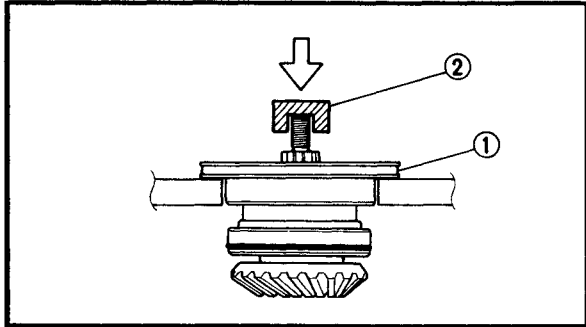

- 3.Remove:
- Bearing housing assembly ①

Bearing housing removal steps:

- Clean the outside of the middle driven shaft.
- Place the middle driven shaft onto a hydraulic press.

CAUTION: _____

- **Never directly press the shaft end with a hydraulic press, this will result in damage to the shaft thread.**
- **Install the suitable socket ② on the shaft end to protect the thread from damage.**

- Press the shaft end and remove the bearing housing.

4.Remove:

- Bearing retainer ①
- Bearing

Removal steps:

- Attach the folded rag ②.
- Secure the bearing housing edge in the vise.
- Attach the bearing retainer wrench ③.

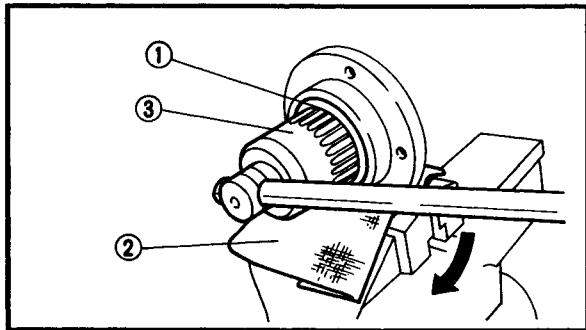

Bearing retainer wrench:
P/N. YM-04128, 90890-04128

CAUTION: _____

The middle driven shaft bearing retainer has left-handed threads. To loosen the retainer turn it clockwise.

- Remove the bearing retainer and bearing.

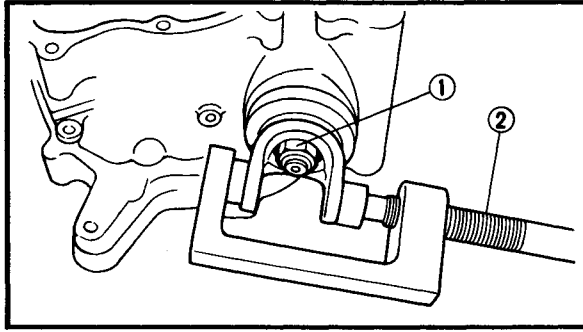

5.Remove:

- Nut ①
- Washer
- Universal joint yoke (front side)

NOTE:

Use the universal joint holder ② to hold the universal joint yoke.



Universal joint holder:

P/N. YM-04062, 90890-04062

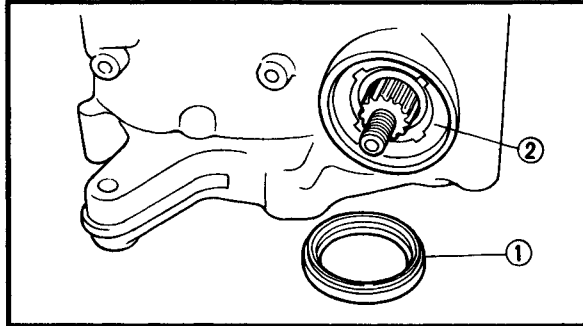

6.Remove:

- Bearing retainer ①
- Bearing ②

NOTE:

Attach the ring nut wrench ③.



Ring nut wrench:

P/N. YM-38404, 90890-01430

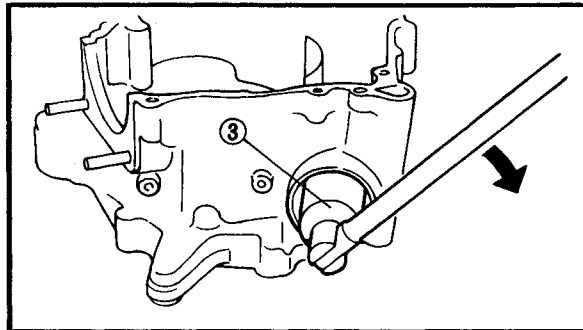

CAUTION:

The middle driven shaft bearing retainer has left-handed threads. To loosen the retainer turn it clockwise.

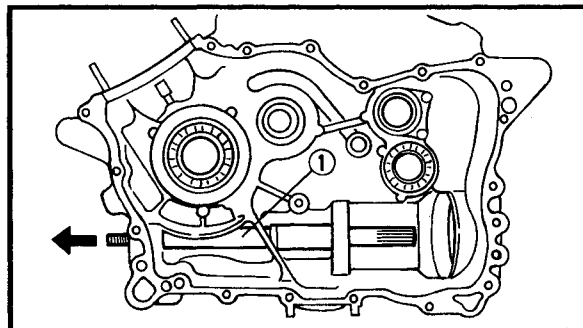

7.Remove:

- Middle drive shaft ①
(with bearing)

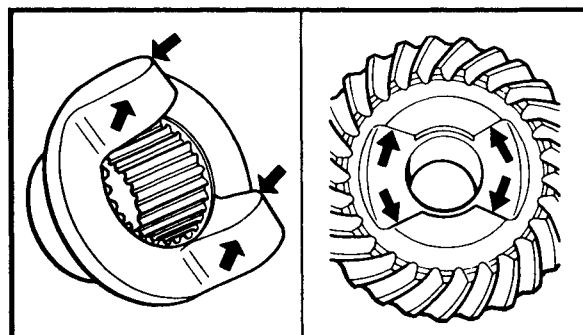

INSPECTION

1.Inspect:

- Damper cam surfaces
Wear/scratches → Replace damper and driven pinion gear as a set.

2.Inspect:

- Damper spring
Damage/cracks → Replace.

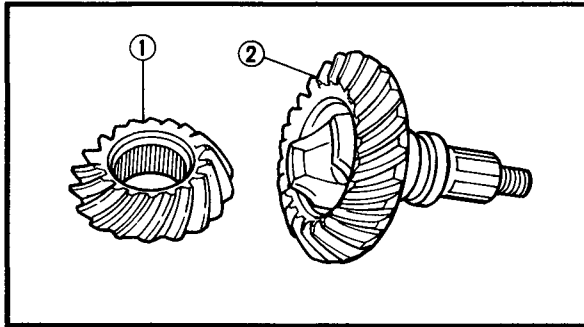

3. Inspect:

- Gear teeth (drive pinion gear) ①
 - Gear teeth (driven pinion gear) ②
- Pitting/galling/wear → Replace.

4. Inspect:

- O-ring
Damage → Replace.
- Bearings
Pitting/damage → Replace.

5. Check:

- U-joint movement
Roughness → Replace U-joint.

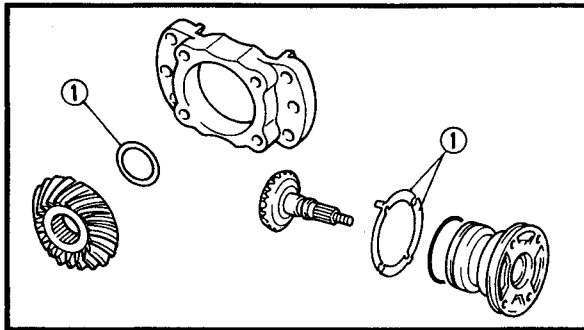

MIDDLE DRIVE AND DRIVEN GEAR SHIM SELECTION

When the drive and driven gear, bearing housing assembly and/or crankcase replaced, be sure to adjust the gear shim ①.

1. Select:

- Middle drive gear shim ①
- Middle driven gear shim ②

Middle drive and driven gear shim selection steps:

- Position middle drive and driven gear by using shims ① and ② with their respective thickness calculated from information marked on crankcase, bearing housing and drive gear end.

① Shim thickness "A"

② Shim thickness "B"

- To find shim thickness "A" use following formula:

Middle drive pinion gear shim thickness:

$$"A" = d - a - b - c$$

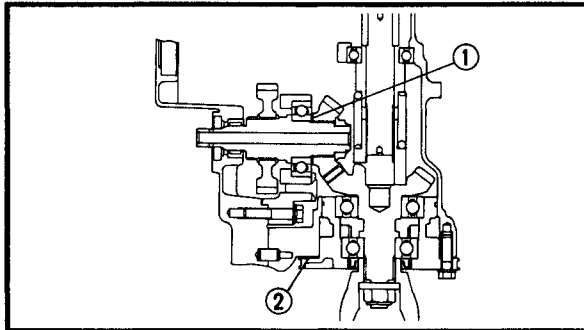

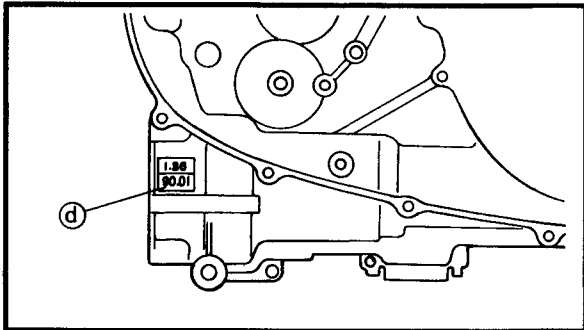
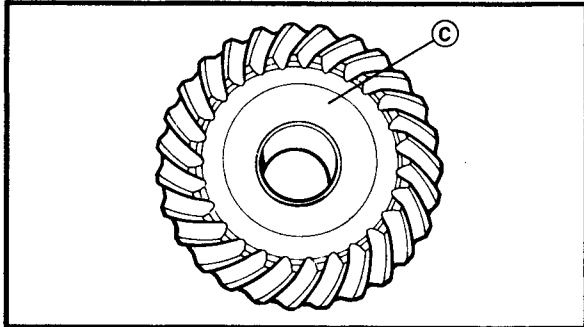
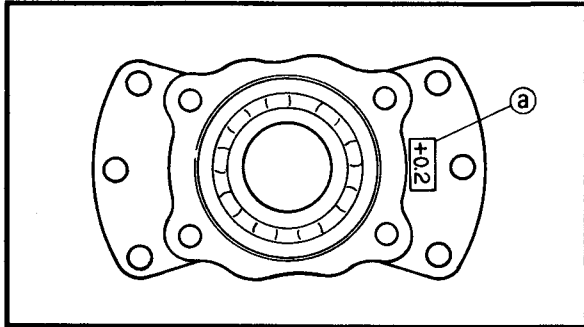

Where:

- Ⓐ = a numeral (usually a decimal number) on the bearing housing is either added to or subtracted from "18.5".
- Ⓑ = bearing thickness (considered constant).
- Ⓒ = thickness (considered constant).
- Ⓓ = a numeral (usually a decimal number) on the right crankcase specifies a thickness of "90".

Example:

- 1) If the bearing housing is marked "+02"
 - Ⓐ is 18.52
- 2) Ⓑ is 16
- 3) Ⓒ is 55
- 4) If the crankcase (right) is marked "90.01"
 - Ⓓ is 90.01
- 5) Therefore, the shim thickness is 0.47 mm

$$A = 90.01 - 18.52 - 16 - 55 = 0.49$$

- 6) Round off hundredths digit and select appropriate shim(s).
In the example above, the calculated shim thickness is 0.49 mm. The chart instructs you, however, to round off 9 to 10.

Hundredths	Round value
0, 1, 2	0
3, 4, 5, 6, 7	5
8, 9	10

Shims are supplied in the following thickness.

 Middle drive pinion gear shim		
Thickness (mm)	0.10	0.30
	0.15	0.40
	0.20	0.50

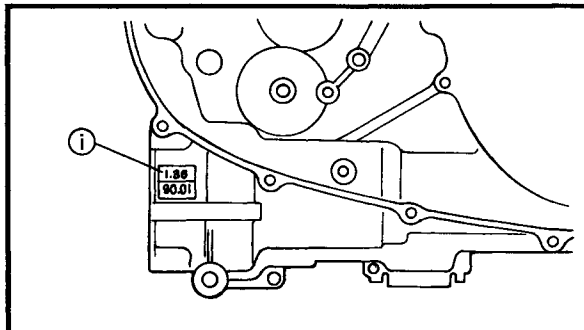
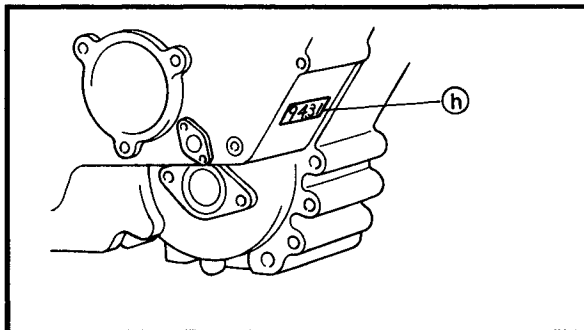
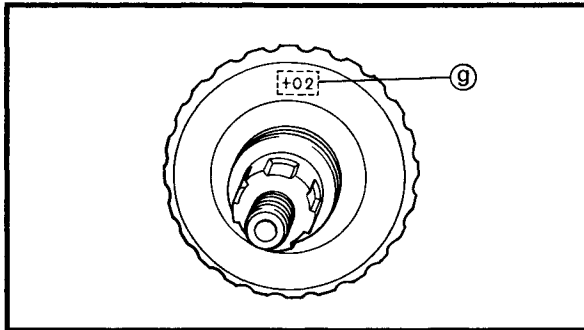
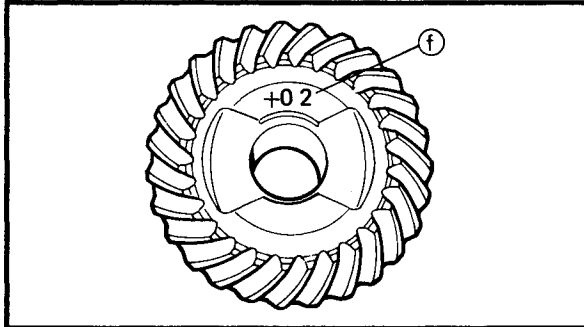
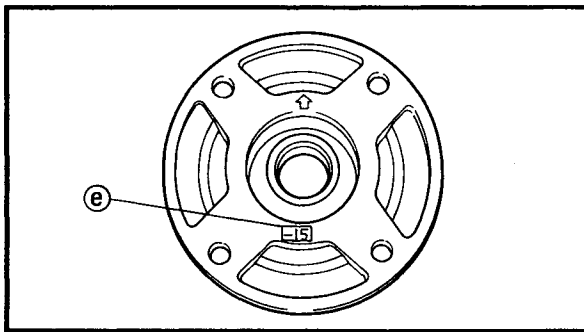

● To find shim thickness "B" use the following formula:

Middle driven pinion gear shim thickness:

$$"B" = \textcircled{e} - \textcircled{f} + \textcircled{g} - \textcircled{h} - \textcircled{i} - 0.05$$

Where:

- ① = a numeral (usually a decimal number) on the bearing housing is either added to or subtracted from "76".
- ② = a numeral (usually a decimal number) on the middle driven pinion gear is either added to or subtracted from "59".
- ③ = a numeral (usually a decimal number) on the middle driven pinion gear is either added to or subtracted from "79.5".
- ④ = a numeral (usually a decimal number) on the left crankcase specifies a thickness of "94.3".
- ⑤ = a numeral (usually a decimal number) on the right crankcase specifies a thickness of "1.3".

Example:

- 1) If the bearing housing is marked "-15" ① is 75.85
- 2) If the driven pinion gear is marked "+02" ② is 59.02
- 3) If the driven pinion gear is marked "+02" ③ is 79.52
- 4) If the crankcase (left) is marked "94.31" ④ is 94.31
- 5) If the crankcase (right) is marked "1.36" ⑤ is 1.36
- 6) Therefore, the shim thickness is 0.63 mm

$$B = 75.85 - 59.02 + 79.52 - 94.31 - 1.36 - 0.05 = 0.63$$

7) Round off hundredths digit and select appropriate shim(s).

In the example above, the calculated shim thickness is 0.63 mm. The chart instructs you, however, to round off 3 to 5.

Hundredths	Round value
0, 1, 2	0
3, 4, 5, 6, 7	5
8, 9	10

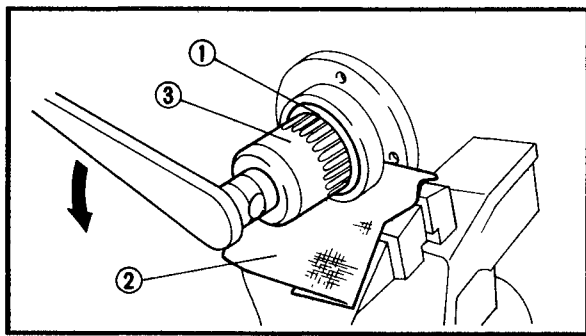

3.Install:

- Bearing retainer ①

Install steps:

- Attach the folded rag ②.
- Secure the bearing housing edge in the vise.
- Attach the bearing retainer wrench ③.



Bearing retainer wrench:
P/N. YM-04128, 90890-04128

- Tighten the bearing retainer.

CAUTION:

The middle driven shaft bearing retainer has left-handed threads. To tighten the retainer turn it counterclockwise.



Bearing retainer:
110 Nm (11.0 m · kg, 80 ft · lb)

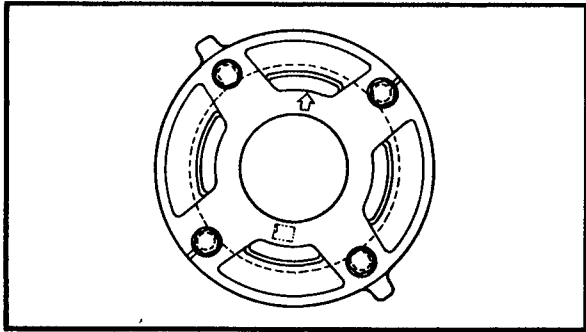

4.Install:

- Shims ①
- Bearing housing

NOTE:

Install the shims so that the tabs are positioned as shown in the illustration.

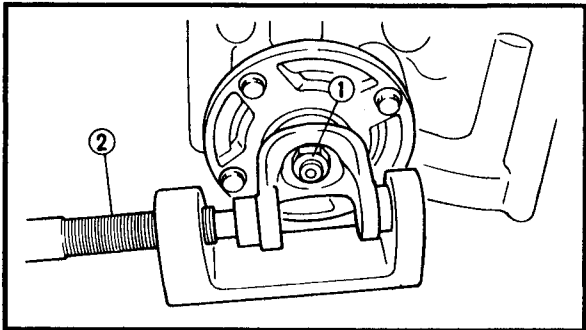

5.Install:

- Universal joint yoke (rear side)
- Washer
- Nut ①

97 Nm (9.7 m · kg, 70 ft · lb)

NOTE:

Use the universal joint holder ② to hold the yoke.



Universal joint holder:
P/N. YM-04062, 90890-04062

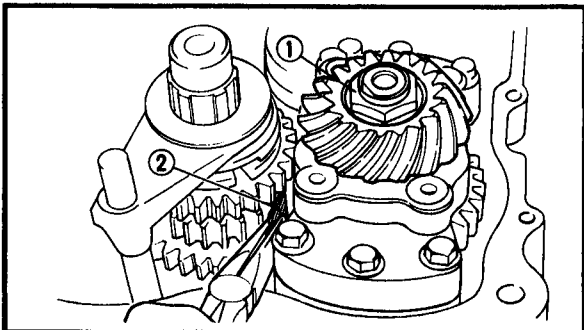
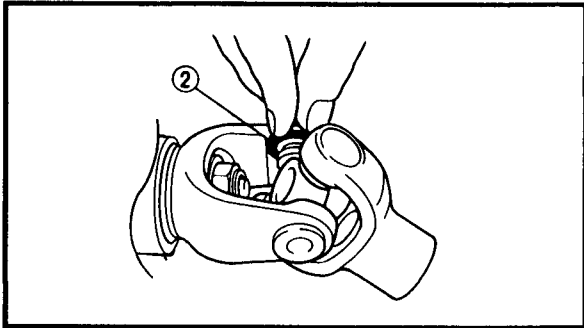
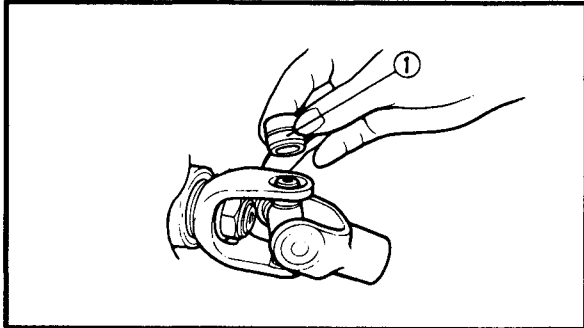
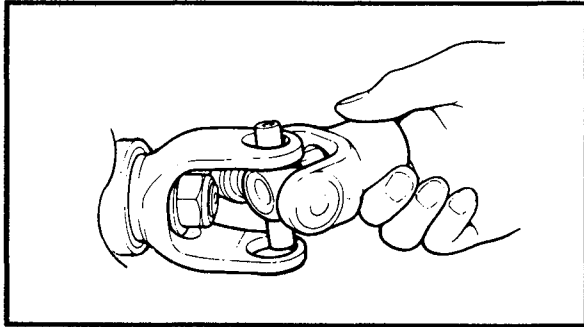

6.Install:

- Universal joint

Universal joint installation steps:

- Install the opposite yoke into the U-joint.
- Apply wheel bearing grease to the bearings.

- Install the bearing ① onto the yoke.

CAUTION:

Check each bearing. The needles can easily fall out of their races. Slide the yoke back and forth on the bearings; the yoke will not go all the way onto a bearing if a needle is out of place.

- Press each bearing into the U-joint using a suitable socket.

NOTE:

The bearing must be inserted far enough into the U-joint so that the circlip can be installed.

- Install the circlips ② into the groove of each bearing.

MIDDLE DRIVE SHAFT INSTALLATION

1.Tighten:

- Nut (middle drive pinion gear) ① **New**
145 Nm (14.5 m · kg, 105 ft · lb)

NOTE:

Place a copper plate ② between teeth of the drive gear and driven gear to lock them.

- 2.Lock the threads with a drift punch.

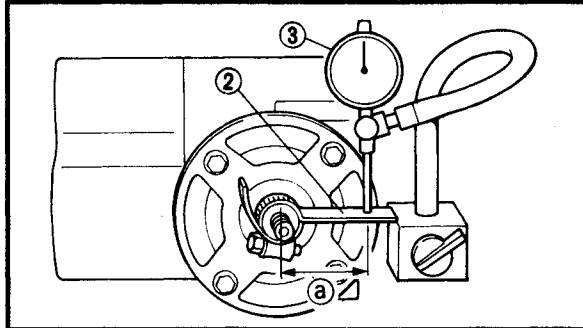
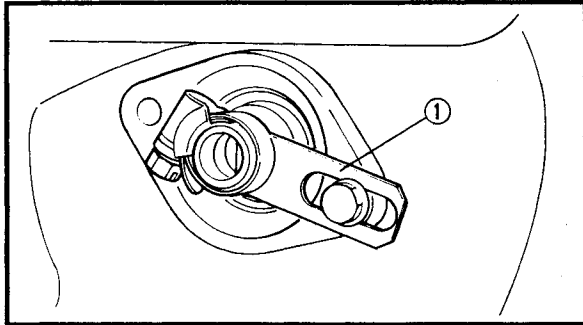

GEAR LASH MEASUREMENT

1.Measure:

- Gear lash

	Middle gear lash: 0.1 ~ 0.3 mm (0.004 ~ 0.012 in)
--	---

Measurement steps:

- Attach the pinion gear fix clamp ① to the middle drive shaft.

	Pinion gear fix clamp: P/N. YM-04129, 90890-04129
--	---

- Attach the gear lash measurement tool ② and dial gauge ③.

	Gear lash measurement tool: P/N. YM-01231, 90890-01231
--	--

③ 46 mm (1.8 in)

- Measure the gear lash while rotating the middle driven shaft back and forth.

NOTE:

Measure the gear lash at 4 positions. Rotate the middle driven gear 90° each time.

- If the gear lash is incorrect, adjust the gear lash by middle driven pinion gear shims and/or middle drive pinion gear shim(s).



CARBURETION

CARBURETOR

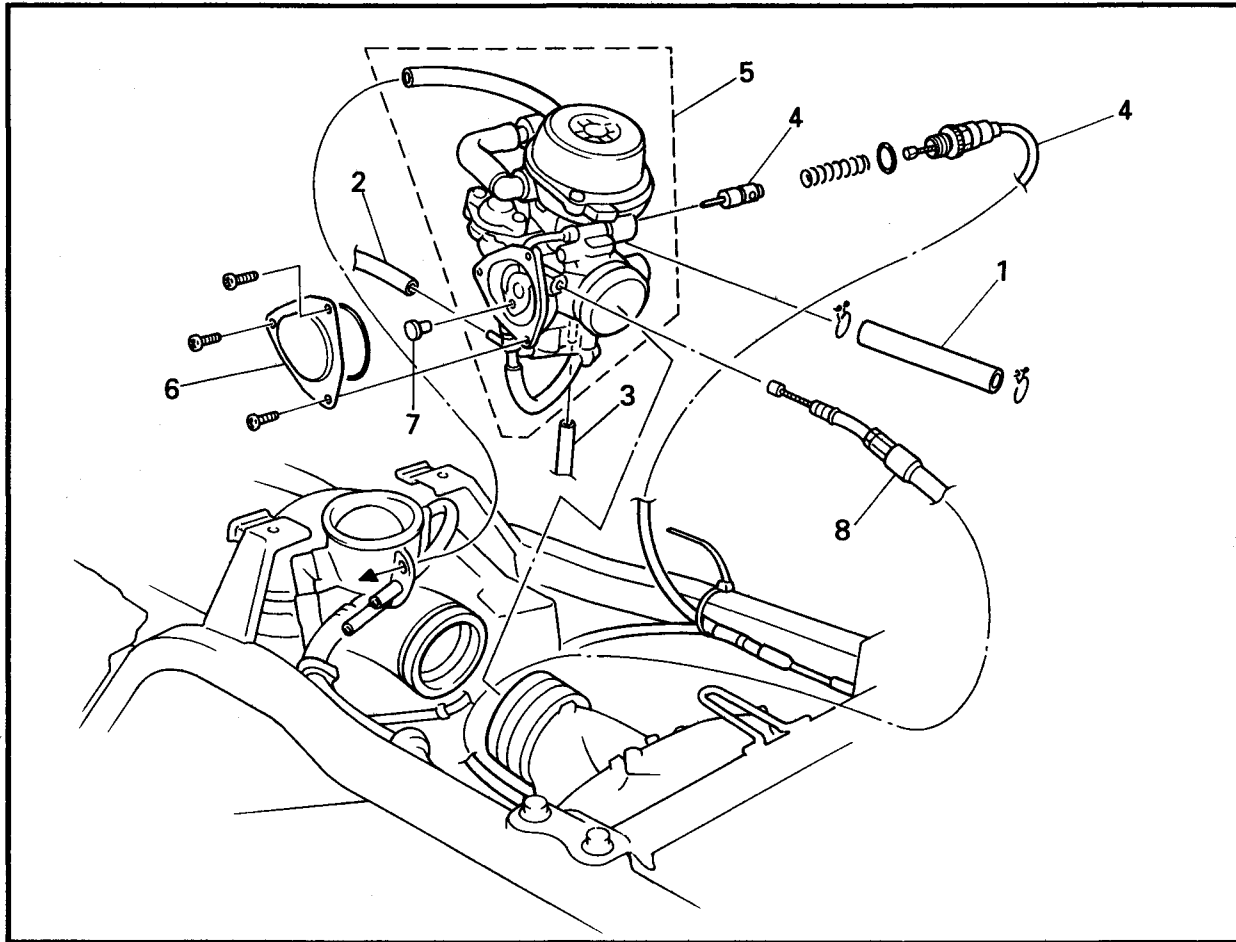

5

Order	Job name/Part name	Q'ty	Remarks
	Carburetor removal		Remove the parts in the order below.
	Fuel tank/rubber cover		Refer to "SEAT, CARRIERS, FENDERS AND FUEL TANK" in CHAPTER 3.
1	Fuel hose	1	
2	Drain hose	1	
3	Overflow hose	1	
4	Starter cable/starter jet	1/1	
5	Carburetor assembly	1	
6	Throttle valve cover	1	
7	Throttle cable end	1	
8	Throttle cable	2	
			NOTE: _____ After removing the carburetor assembly, remove the throttle cable. _____
			For installation, reverse the removal procedure.

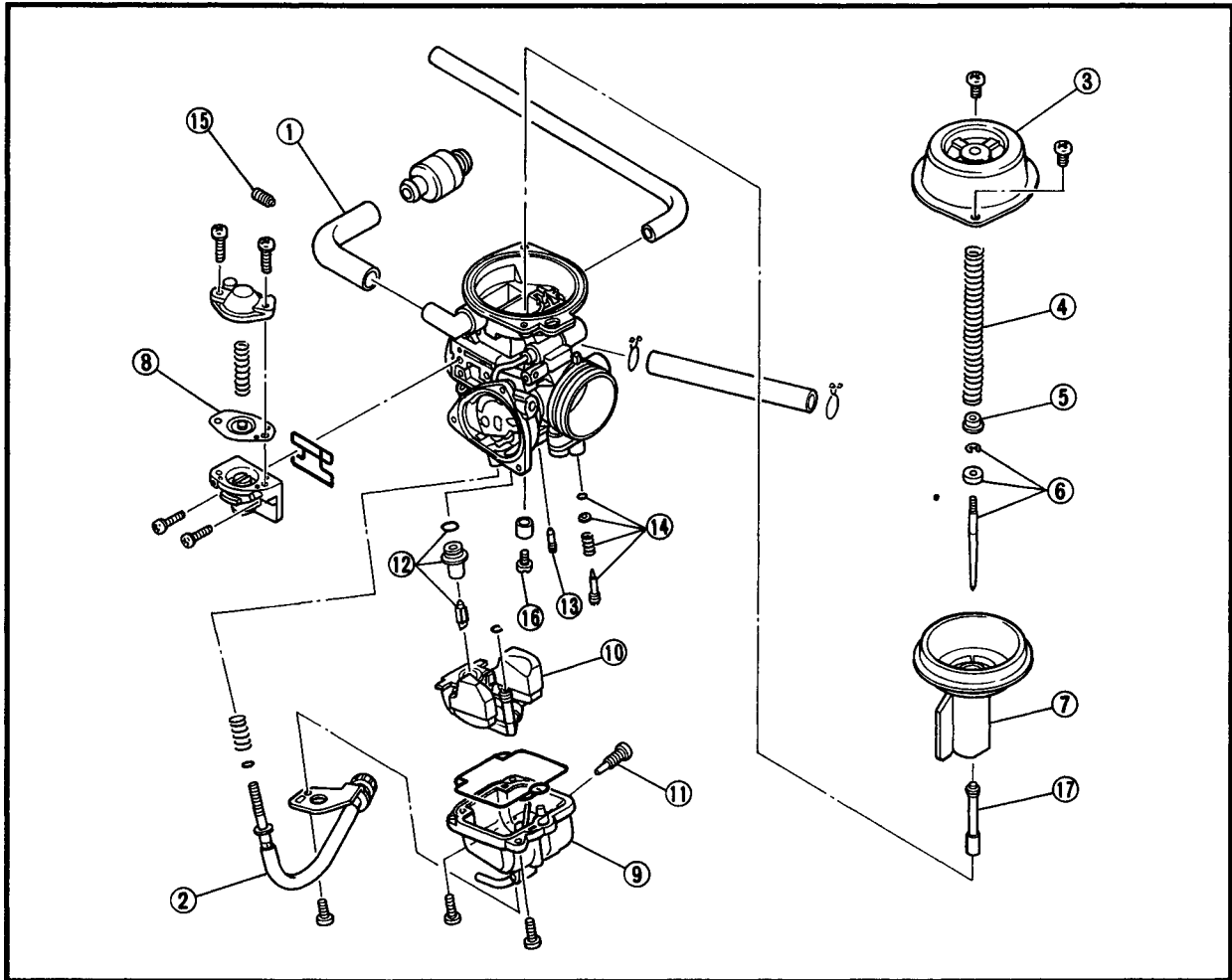

Order	Job name/Part name	Q'ty	Remarks
	Carburetor disassembly		Disassemble the parts in the order below.
①	Air vent hose	2	
②	Throttle stop screw	1	
③	Vacuum chamber cover	1	
④	Spring	1	
⑤	Spring seat	1	
⑥	Jet needle set	1	
⑦	Piston valve	1	
⑧	Coasting enricher diaphragm	1	
⑨	Float chamber	1	
⑩	Float	1	Refer to "CARBURETOR ASSEMBLY".
⑪	Drain screw	1	
⑫	Needle valve set	1	

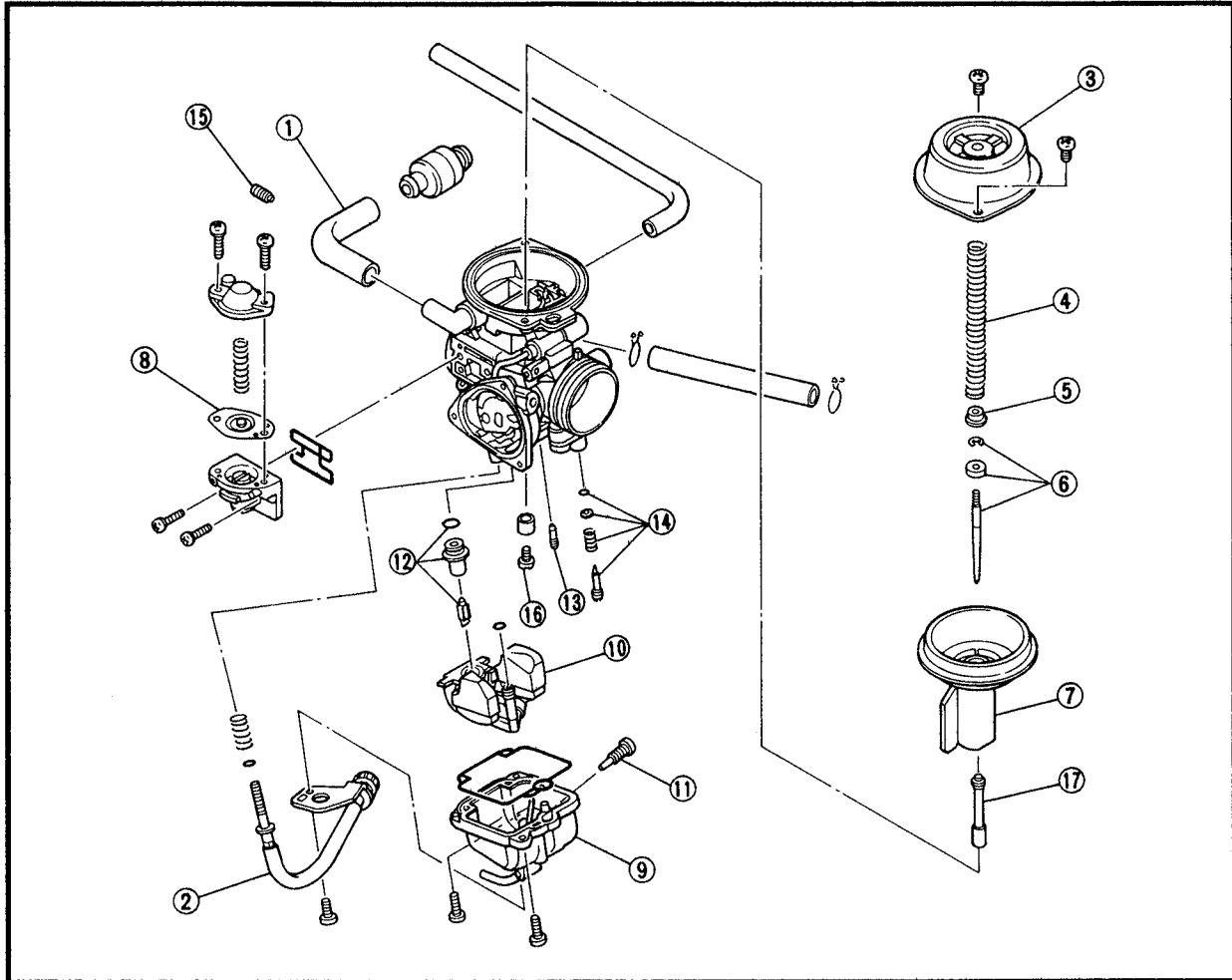

Order	Job name/Part name	Q'ty	Remarks
⑬	Pilot jet	1	
⑭	Pilot screw set	1	Refer to "CARBURETOR ASSEMBLY".
⑮	Pilot air jet	1	
⑯	Main jet	1	
⑰	Needle jet	1	Refer to "CARBURETOR DISASSEMBLY/ASSEMBLY". For assembly, reverse the disassembly procedure.

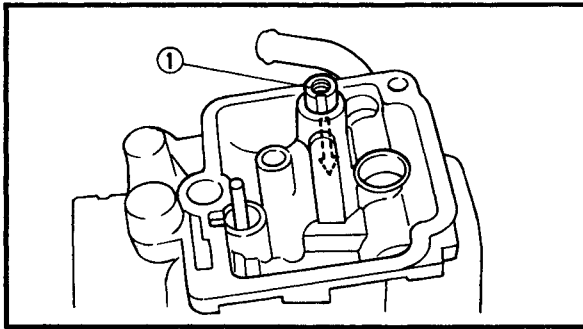

CARBURETOR DISASSEMBLY

- 1.Remove:
- Needle jet ①

NOTE: _____
Remove the needle jet towards the piston valve side.

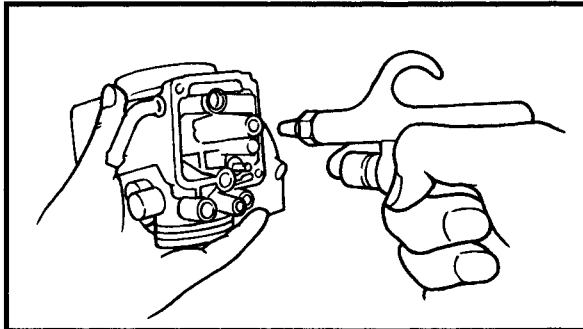

CARBURETOR INSPECTION

- 1.Inspect:
- Carburetor body
 - Starter jet ①
 - Float chamber
Cracks/damage → Replace.
 - Fuel passage
Contamination → Clean as indicated.
 - Fuel chamber body
Contamination → Clean.

Cleaning steps:

- Wash the carburetor in a petroleum based solvent.
(Do not use any caustic carburetor cleaning solution.)
- Blow out all of the passages and jets with compressed air.

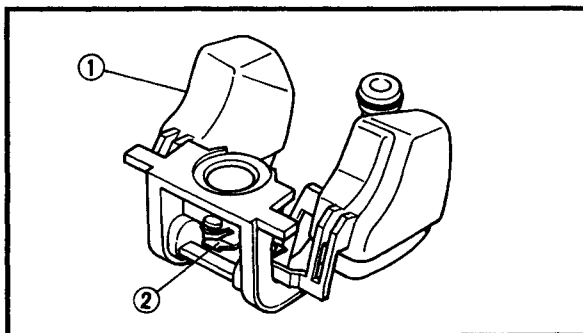
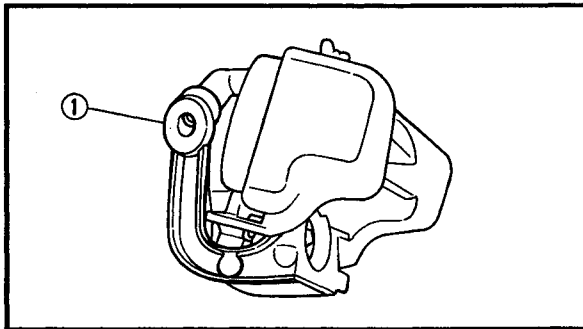

- 2.Inspect:
- Float ①
 - Float tang ②
Damage → Replace.

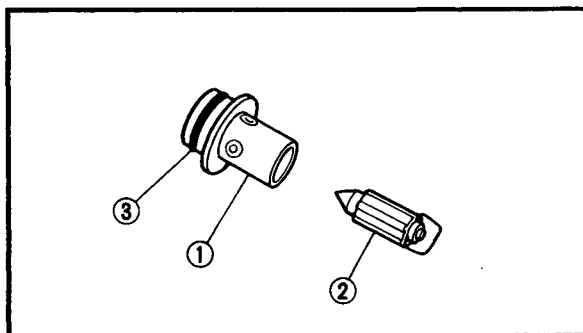

- 3.Inspect:
- Valve seat ①
 - Needle valve ②
 - O-ring ③
Contamination/wear/damage → Replace as a set.

NOTE: _____
Always replace the needle valve and valve seat as a set.

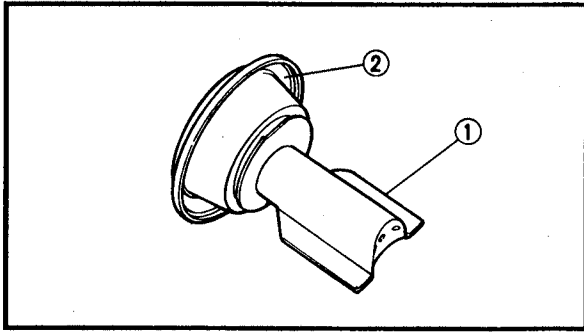

4. Inspect:

- Piston valve ①
Scratches/wear/damage → Replace.
- Rubber diaphragm ②
Tears → Replace.

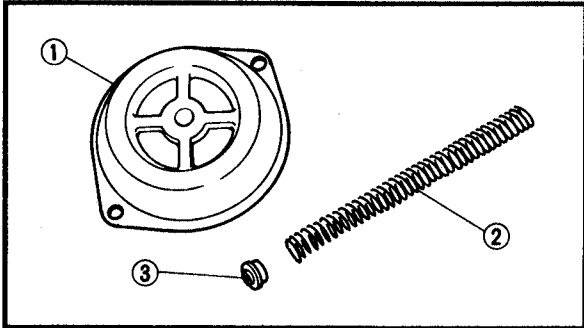

5. Inspect:

- Vacuum chamber cover ①
- Spring ②
- Spring seat ③
Cracks/damage → Replace.

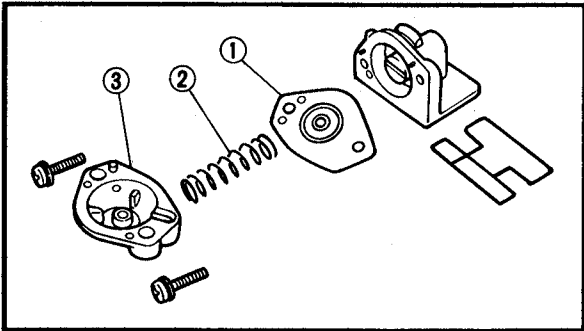

6. Inspect:

- Diaphragm (coasting enricher) ①
- Spring ②
- Cover ③
Tears (diaphragm) /damage → Replace.

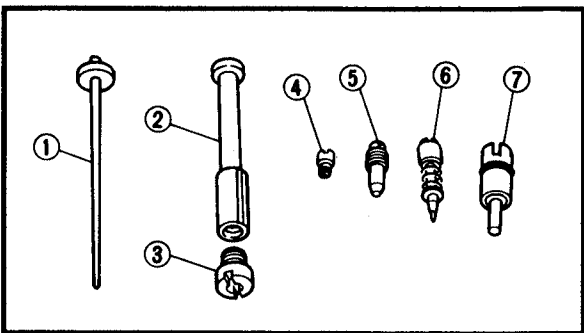

7. Inspect:

- Jet needle ①
- Needle jet ②
- Main jet ③
- Pilot air jet ④
- Pilot jet ⑤
- Pilot screw ⑥
- Starter plunger ⑦
Bends/wear/damage → Replace.
- Blockage → Blow out the jets with compressed air.

CARBURETOR

CARB

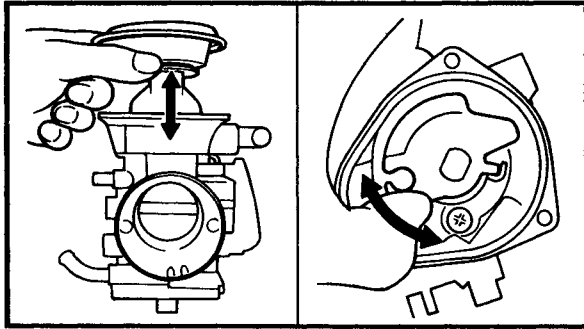

8. Check:

- Free movement (piston valve)
Sticks → Replace piston valve guide and piston valve.
Insert the piston valve into the carburetor body, and check for free movement.

9. Check:

- Free movement (throttle valve)
Sticks → Replace.

CARBURETOR ASSEMBLY

CAUTION:

Before reassembling, wash all of the parts in a clean petroleum based solvent.

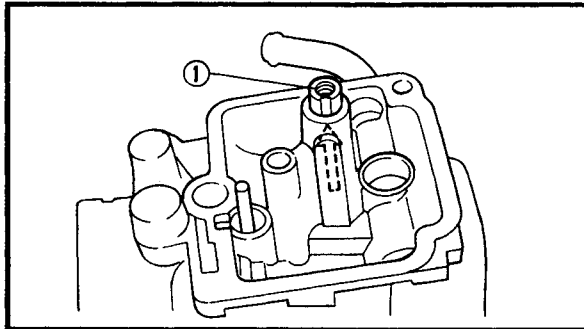

1. Install:

- Needle jet ①

NOTE:

- Align the groove on the needle jet with the projection on the carburetor body.
- Install the needle jet from the piston valve side.

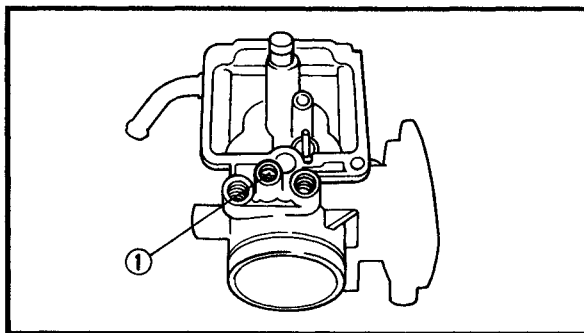

2. Install:

- Pilot screw ①



**Pilot screw (turns out):
3 1/2**

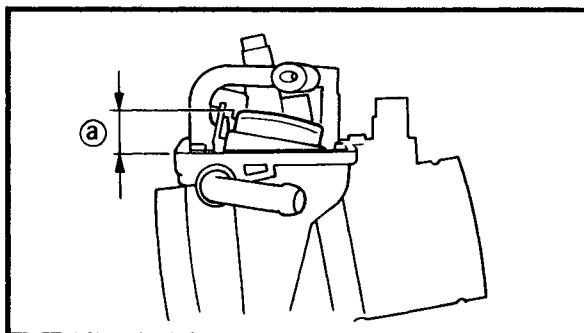

3. Measure:

- Float height ②
Out of specification → Adjust.



**Float height (F.H.):
14.7 mm (0.59 in)**

Measurement and adjustment steps:

- Hold the carburetor in an upside down position.

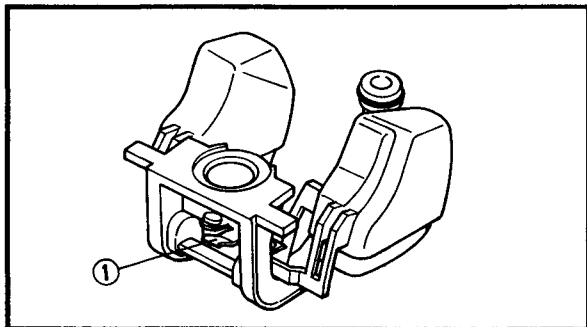

- Measure the distance from the front mating surface of the float chamber (gasket removed) to the top of the float.

NOTE:

The float arm should be resting on the needle valve, but not compressing it.

- If the float height is not within the specification, inspect the valve seat and needle valve.
- If either is worn, replace them both.
- If both are fine, adjust the float height by bending the float tang ① on the float.
- Recheck the float height.

FUEL LEVEL ADJUSTMENT

1. Measure:

- Fuel level ①
- Out of specification → Adjust.

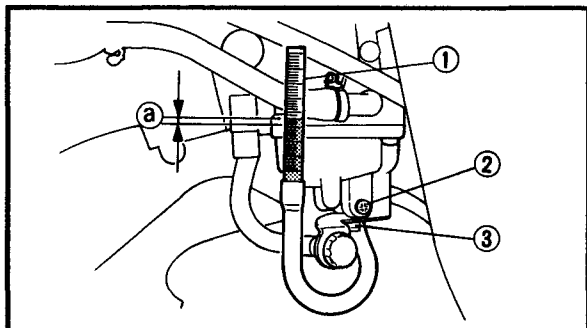

Fuel level:
2.0 ~ 3.0 mm (0.08 ~ 0.12 in)
Above the float chamber mating surface

Fuel level measurement and adjustment steps:

- Place the machine on a level surface.
- Connect the fuel level gauge ① to the drain pipe ②.



Fuel level gauge:
P/N. YM-01312-A, 90890-01312

- Loosen the drain screw ③.
- Hold the gauge vertically next to the float chamber line.
- Measure the fuel level ① with the gauge.
- If the fuel level is incorrect, adjust the fuel level.
- Remove the carburetor.
- Inspect the valve seat and needle valve.
- If either is worn, replace them both.
- If both are fine, adjust the float level by bending the float tang ④ slightly.
- Install the carburetor.
- Recheck the fuel level.

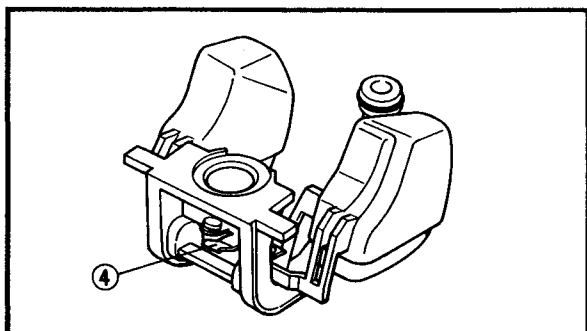

DRIVE TRAIN

TROUBLESHOOTING

The following conditions may indicate damaged shaft drive components:

Symptoms	Possible Causes
1.A pronounced hesitation or "jerky" movement during acceleration, deceleration, or sustained speed. (This must not be confused with engine surging or transmission characteristics.) 2.A "rolling rumble" noticeable at low speed; a high-pitched whine; a "clunk" from a shaft drive component or area. 3.A locked-up condition of the shaft drive train mechanism, no power transmitted from the engine to the front and/or rear wheel.	A.Bearing damage. B.Improper gear lash. C.Gear tooth damage. D.Broken drive shaft. E. Broken gear teeth. F. Seizure due to lack of lubrication. G.Small foreign objects lodged between the moving parts.

NOTE:

Areas A, B, and C above may be extremely difficult to diagnose. The symptoms are quite subtle and difficult to distinguish from normal machine operating noise. If there is reason to believe these components are damaged, remove the components and inspect them.

Inspection notes

1.Investigate any unusual noises.

The following "noises" may indicate a mechanical defect:

- a.A "rolling rumble" noise during coasting, acceleration, or deceleration. The noise increases with front and/or rear wheel speed, but it does not increase with higher engine or transmission speeds.
 Diagnosis: Possible wheel bearing damage.
- b.A "whining" noise that varies with acceleration and deceleration.
 Diagnosis: Possible incorrect reassembly, too-little gear lash.



CAUTION

Too-little gear lash is extremely destructive to the gear teeth. If a test ride following reassembly indicates this condition, stop riding immediately to minimize gear damage.

c.A slight "thunk" evident at low speed operation. This noise must be distinguished from normal machine operation. Diagnosis: Possible broken gear teeth.

⚠ WARNING

Stop riding immediately if broken gear teeth are suspected. This condition could result in the shaft drive assembly locking-up, causing loss of control of the machine and possible injury to the rider.

2.Inspect:

- Drained oil
Drain plug shows large amounts of metal. Particles → Check the bearing for seizure.

NOTE:

A small amount of metal particles in the oil is normal.

3.Inspect:

- Oil leakage

Oil leakage inspection steps:

- Clean the entire machine thoroughly, then dry it.
- Apply a leak-localizing compound or dry powder spray to the shaft drive.
- Road test the machine for the distance necessary to locate the leak.
Leakage → Inspect the component housing, gasket, and/or seal for damage.
Damage → Replace the component.

NOTE:

- An apparent oil leak on a new or nearly new machine may be the result of a rust-preventative coating or excessive seal lubrication.
- Always clean the machine and recheck the suspected location of an apparent leakage.



Troubleshooting Chart

When basic condition "a" and "b" exist, check the following points:

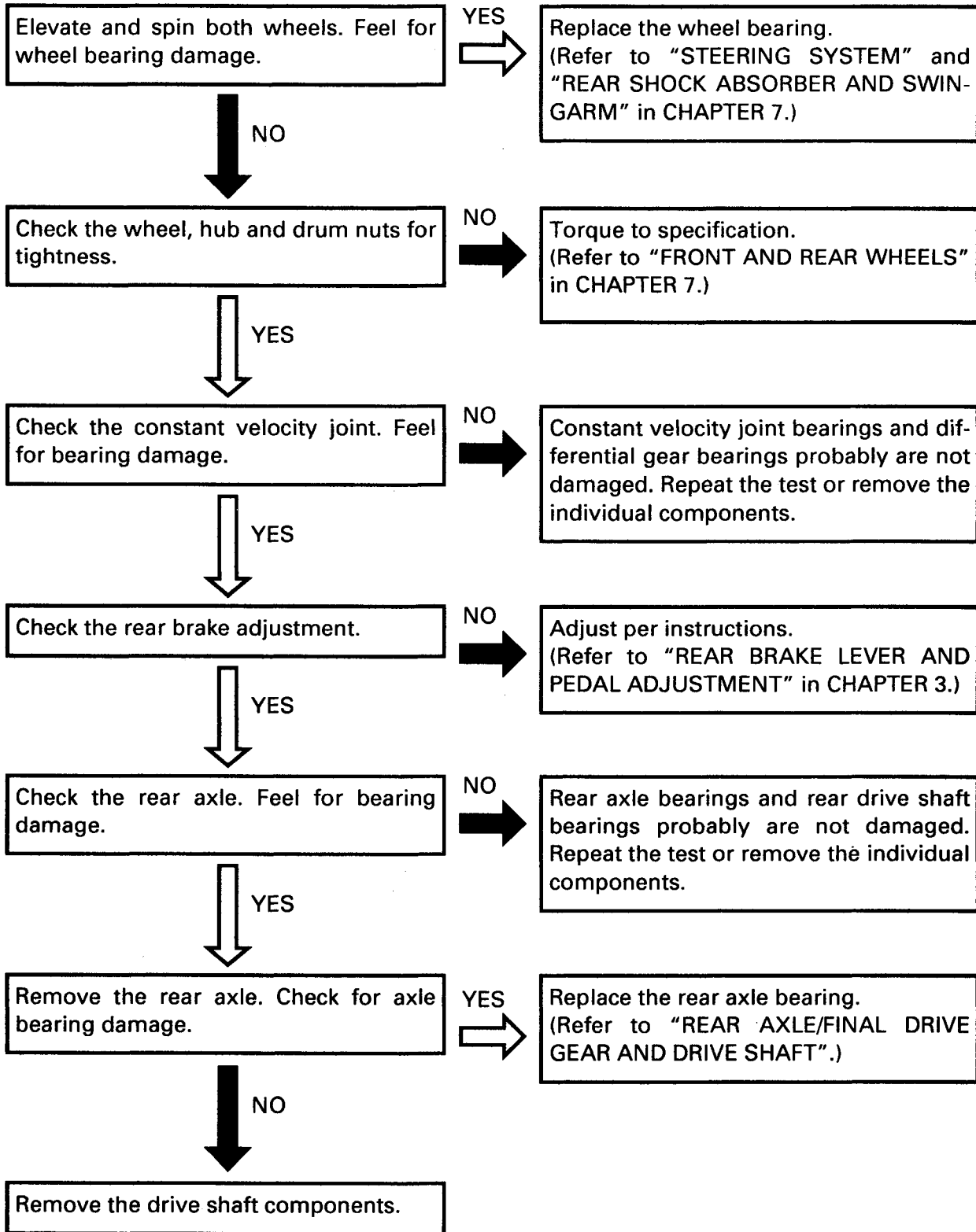

CONSTANT VELOCITY JOINTS AND DIFFERENTIAL GEAR



CONSTANT VELOCITY JOINTS AND DIFFERENTIAL GEAR

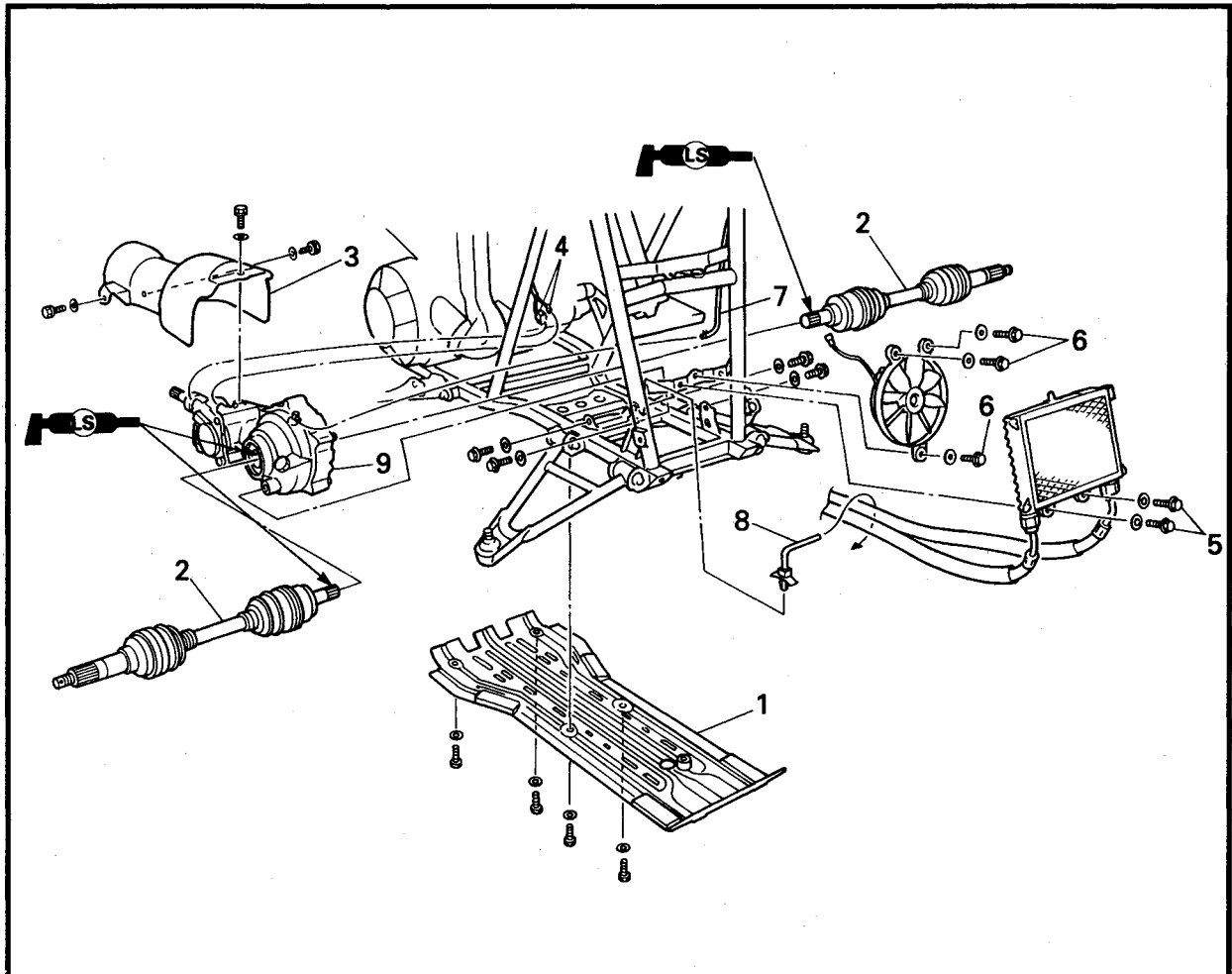

Order	Job name/Part name	Q'ty	Remarks
	Constant velocity joints and differential gear removal		Remove the parts in the order below.
	Front fender		Refer to "SEAT, CARRIERS, FENDERS AND FUEL TANK" in CHAPTER 3.
	Differential gear oil		Drain
	Steering knuckle		Refer to "STEERING SYSTEM" in CHAPTER 7.
1	Engine skid plate	1	
2	Constant velocity joint	2	
3	Front drive shaft protector	1	
4	Gear motor coupler / 4WD switch lead	1/1	
5	Oil cooler mounting bolt	2	
6	Fan mounting bolt	3	

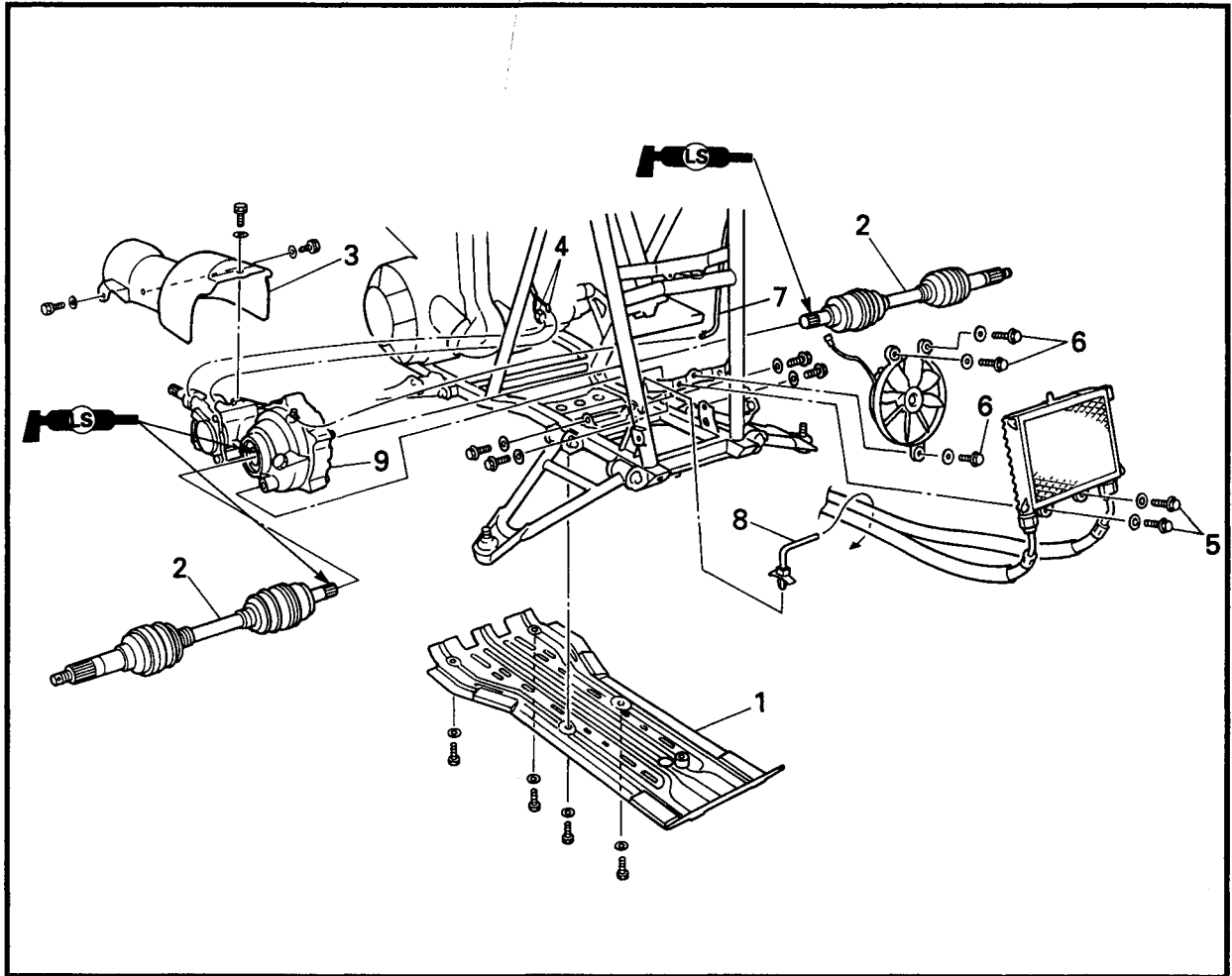

Order	Job name/Part name	Q'ty	Remarks
7	Differential gear breather hose	1	Disconnect For installation, reverse the removal procedure.
8	Plastic clamp	1	
9	Differential gear	1	

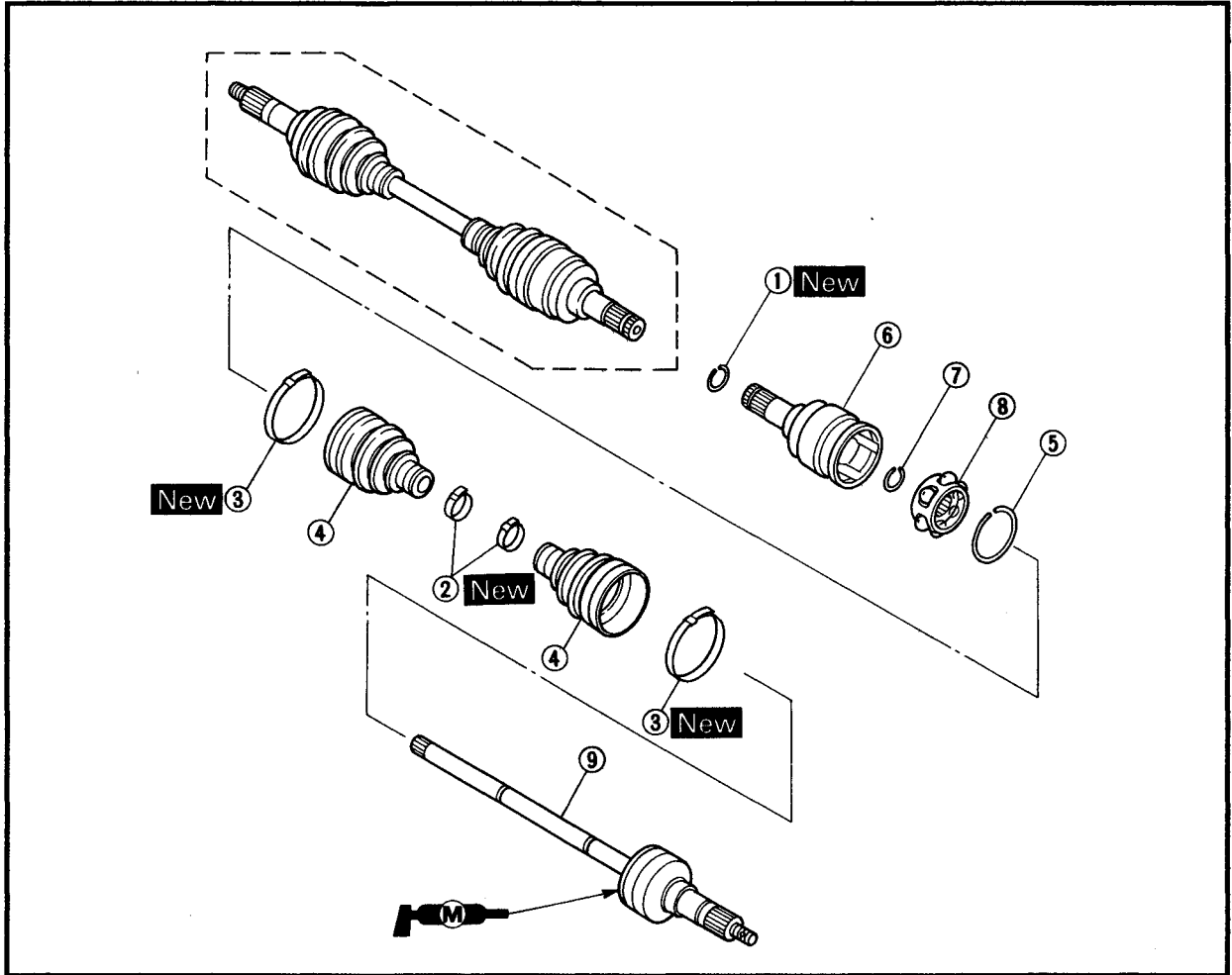

Order	Job name/Part name	Q'ty	Remarks
	Constant velocity joint disassembly		Disassemble the parts in the order below.
①	Circlip	1	Refer to "CONSTANT VELOCITY JOINT ASSEMBLY".
②	Boot band	2	
③	Boot band	2	
④	Dust boot	2	
⑤	Circlip	1	
⑥	Double off-set joint	1	
⑦	Snap ring	1	
⑧	Ball bearing	1	
⑨	Joint shaft assembly	1	
			For assembly, reverse the disassembly procedure.

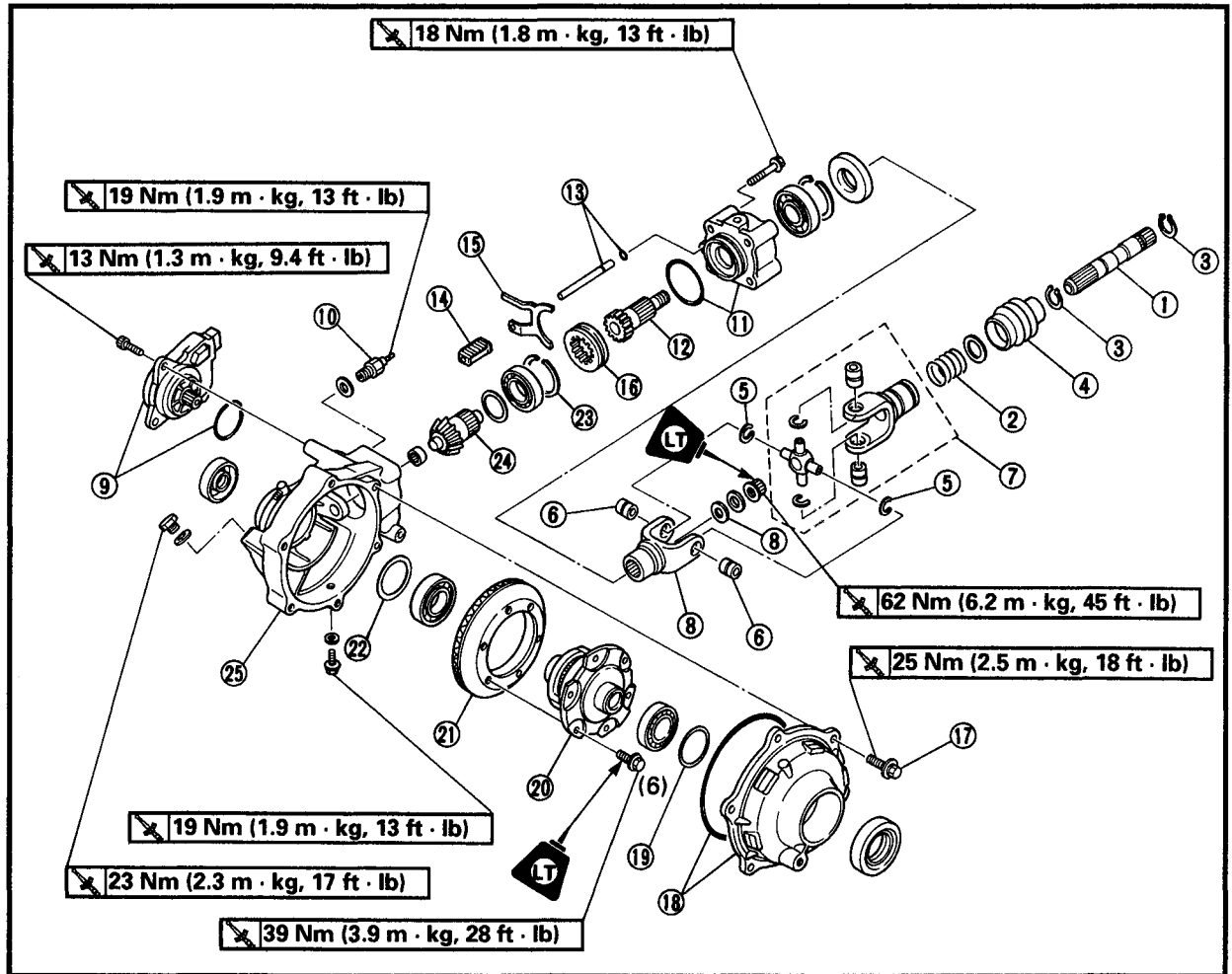

Order	Job name/Part name	Q'ty	Remarks
	Differential gear disassembly		Disassemble the parts in the order below.
①	Front drive shaft	1	Refer to "UNIVERSAL JOINT DISASSEMBLY AND ASSEMBLY".
②	Compression spring	1	
③	Circlip	2	
④	Rubber boot	1	
⑤	Circlip	2	
⑥	Bearing	2	
⑦	Universal joint	1	
⑧	Universal joint yoke/O-ring	1/1	
⑨	Gear motor/O-ring	1/1	
⑩	4WD switch	1	
⑪	Bearing housing/O-ring	1/1	
⑫	Input shaft	1	
⑬	Shift fork shaft/O-ring	1/1	

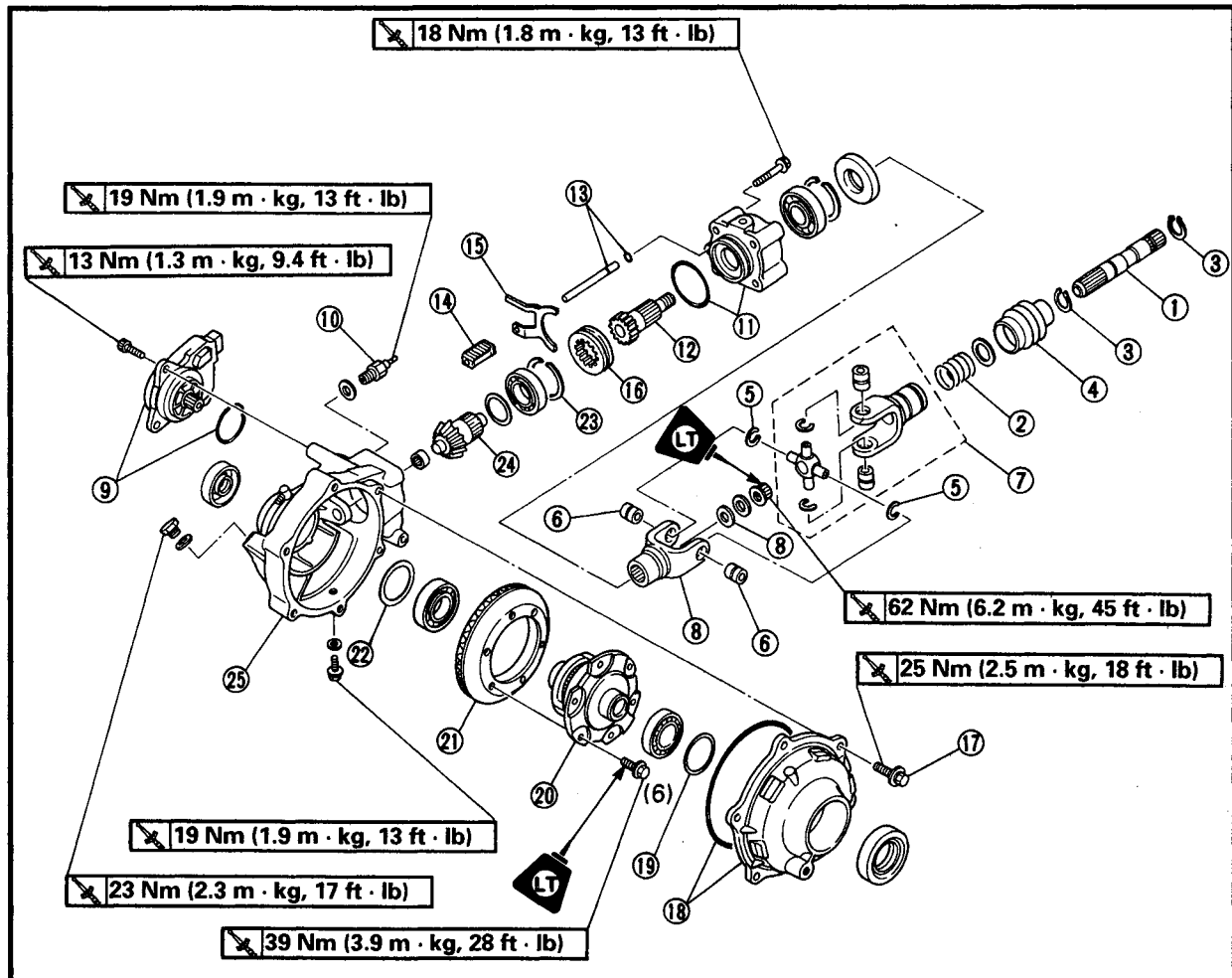

Order	Job name/Part name	Q'ty	Remarks
⑭	Shift fork sliding gear	1	NOTE: _____ Working in a crisscross pattern, loosen each bolt 1/4 of a turn. After all the bolts are loosened, remove them.
⑮	Shift fork	1	
⑯	2WD/4WD shift sleeve	1	
⑰	Bolt	6	
⑱	Bearing housing/O-ring	1/1	
⑲	Shim (left)	1	
⑳	Differential gear assembly	1	Refer to "DIFFERENTIAL GEAR DISASSEMBLY".
㉑	Ring gear	1	
㉒	Shim (right)	1	For assembly, reverse the disassembly procedure.
㉓	Snap ring	1	
㉔	Drive pinion gear	1	
㉕	Differential gear case	1	

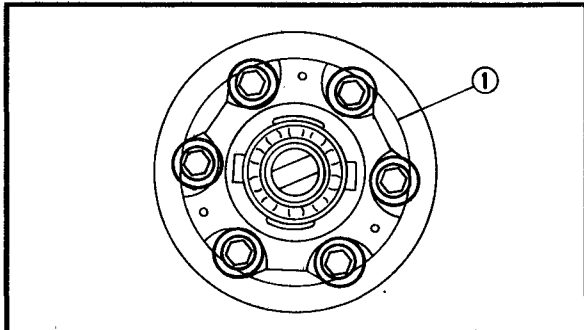
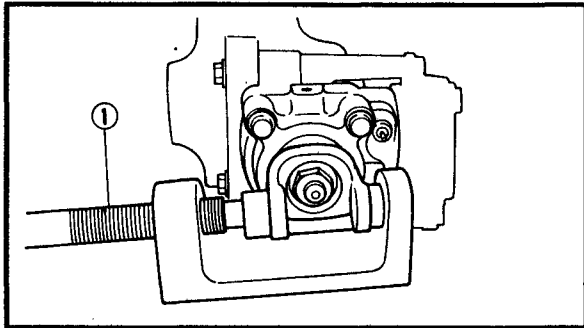
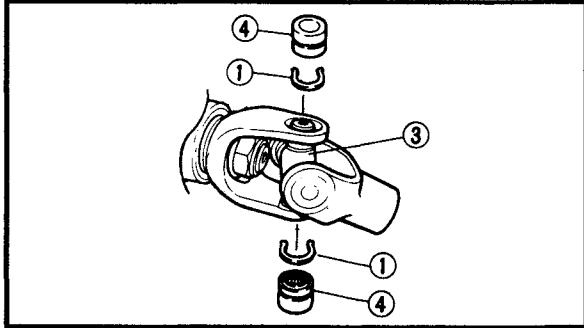
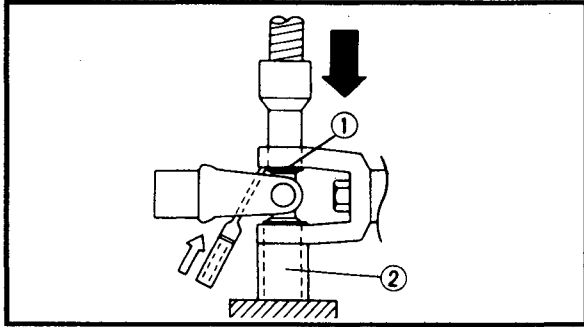

UNIVERSAL JOINT DISASSEMBLY

1.Remove:

- Universal joint

Universal joint removal steps:

- Remove the circlips ①.
- Place the U-joint in a press.
- With a suitable diameter pipe ② beneath the yoke ③, press the bearing ④ into the pipe as shown.

NOTE: _____
It may be necessary to lightly tap the yoke with a punch.

- Repeat the steps for the opposite bearing.
- Remove the yoke.

NOTE: _____
It may be necessary to lightly tap the yoke with a punch.

2.Remove:

- Universal joint yoke
Use a universal joint holder ①.

	<p>Universal joint holder: P/N. YM-04062, 90890-04062</p>
--	--

DIFFERENTIAL GEAR DISASSEMBLY

1.Remove:

- Ring gear ①

NOTE: _____
The ring gear and the differential gear cover should be fastened together. Do not disassemble the differential gear.

CAUTION: _____
The differential gears are assembled into a proper unit at the factory by means of specialized equipment. Do not attempt to disassemble this unit. Disassembly will result in the malfunction of the unit.



CONSTANT VELOCITY JOINT INSPECTION

1. Inspect:

- Double off-set joint spline
 - Ball joint spline
 - Shaft spline
- Wear/damage → Replace.

2. Inspect:

- Dust boots
- Cracks/damage → Replace.

CAUTION:

Always use a new boot band.

3. Inspect:

- Balls and ball races
 - Inner surface of double off-set joint
- Pitting/wear/damage → Replace.

DIFFERENTIAL GEAR INSPECTION

1. Inspect:

- Gear teeth
- Pitting/galling/wear → Replace front drive gear and ring gear as a set.
- Bearing
- Pitting/damage → Replace.
- Oil seal
 - O-ring
- Damage → Replace.

2. Inspect:

- Drive shaft splines
 - Universal joints
 - Front drive gear splines
- Wear/damage → Replace.
- Spring
- Fatigue → Replace.
- Move the spring up and down.

3. Inspect:

- Front drive shaft
- Bends → Replace.

⚠ WARNING

Do not attempt to straighten a bent shaft; this may dangerously weaken the shaft.

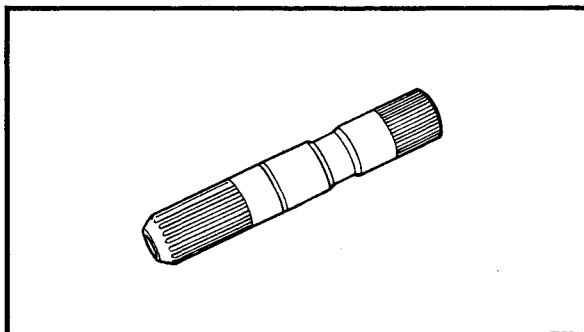



CONSTANT VELOCITY JOINT ASSEMBLY

1. Apply:

- Molybdenum disulfide grease
(into the ball joint assembly)

NOTE: _____

Molybdenum disulfide grease is included in the repair kit.

2. Install:

- Dust boots ①
- Boot bands ② ③ **New**

Installation steps:

NOTE: _____

- The new boot bands may differ from the original ones.
 - The dust boots should be fastened with the boot bands ③ at the grooves in the joint shaft.
-
- Apply molybdenum disulfide grease into the dust boots.

	Molybdenum disulfide grease: 70 g (2.5 oz) per dust boot
---	---

- Install the dust boots ①.
- Wrap the boot bands around the dust boots twice, then pass the band ends through the loops ③.
- Tighten the boot bands by pulling the boot band ends with pliers until the boot band outside diameters meet specification.

Boot band ②:	69 mm (2.7 in)
Boot band ③:	26.1 mm (1.0 in)

- Bend the ends of the boot bands at the loops ③.
- Secure the boot bands by holding a punch over the center of the loops ③ and hitting the punch with a hammer. Be careful not to damage the dust boots.
- Cut off the excess boot band ends so that they are the specified length.

Boot band ②:	Length from loop ③ to tab ④
Boot band ③:	Length equal to the width of boot band ③

- Firmly bend the ends of the boot bands over the loops ③. Secure the boot bands by bending the tabs ④ over the boot band ends ②.

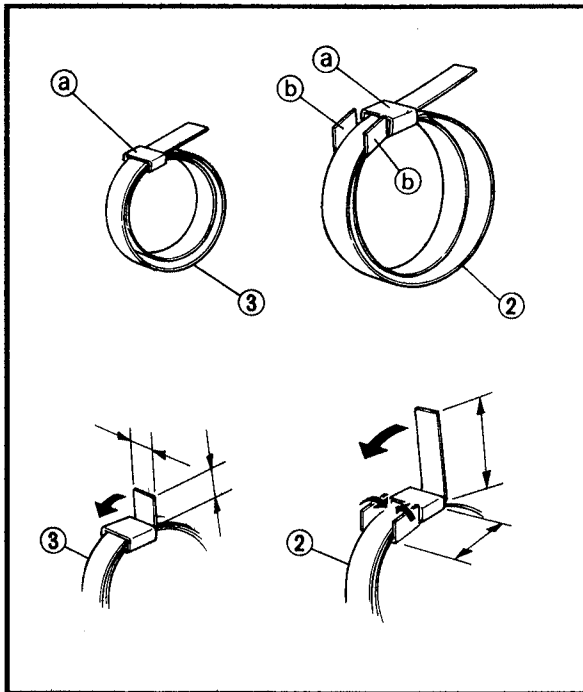
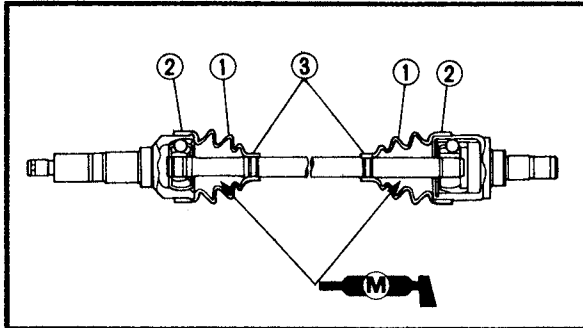

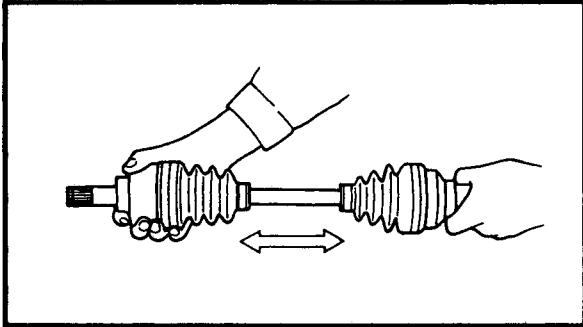



3. Check:
- Free play (thrust movement)
Excessive play → Replace the joint assembly.

DIFFERENTIAL GEAR ASSEMBLY

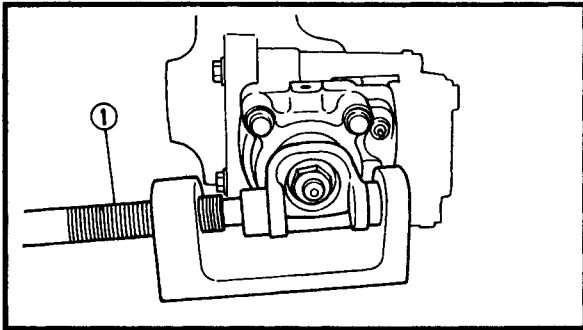
1. Measure:
- Gear lash
Refer to "DIFFERENTIAL GEAR LASH MEASUREMENT/ADJUSTMENT".
2. Install:
- Gear motor
Refer to "FEATURES" in CHAPTER 1.



3. Install:
- Universal joint yoke
 - O-ring
 - Washer
 - Nut  **62 Nm (6.2 m · kg, 45 ft · lb)**
- Use a universal joint holder ①.

	Universal joint holder: P/N. YM-04062, 90890-04062
---	--

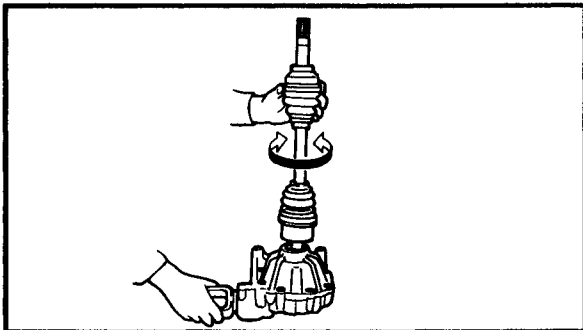

4. Check:
- Differential gear operation
Unsmooth operation → Replace the differential gear assembly.
Insert the double off-set joint into the differential gear, and turn the gear back and forth.

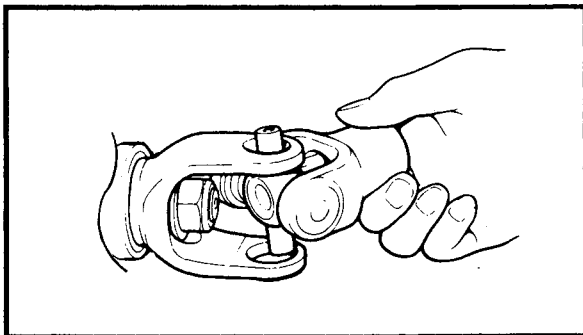

UNIVERSAL JOINT INSTALLATION

1. Install:
- Universal joint
- *****
- Universal joint installation steps:**
- Install the opposite yoke into the U-joint.
 - Apply wheel bearing grease to the bearings.

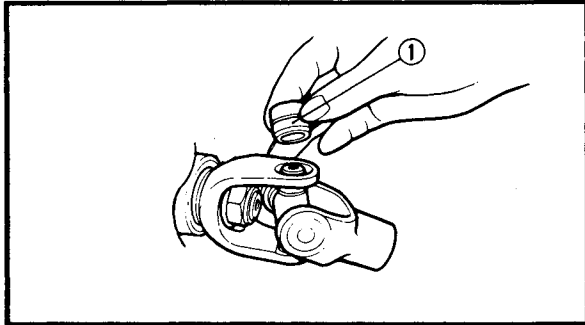

- Install the bearing ① onto the yoke.

CAUTION:

Check each bearing. The needles can easily fall out of their races. Slide the yoke back and forth on the bearings; the yoke will not go all the way onto a bearing if a needle is out of place.

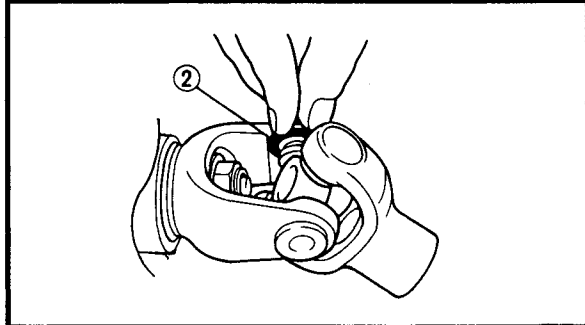

- Press each bearing into the U-joint using a suitable socket.

NOTE:

The bearing must be inserted far enough into the U-joint so that the circlip can be installed.

- Install the circlips ② into the groove of each bearing.

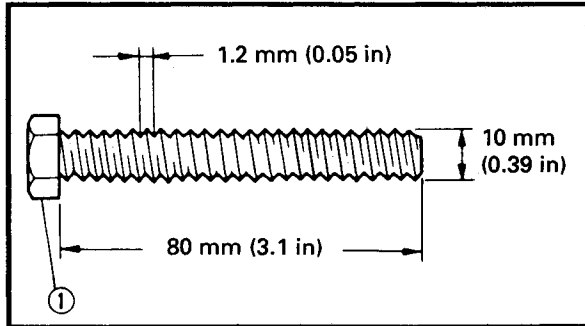

DIFFERENTIAL GEAR LASH MEASUREMENT AND ADJUSTMENT

Differential gear lash measurement

1. Secure the gear case in a vise or another supporting device.

2. Remove:

- Drain plug
- Gasket

3. Install:

- A bolt of the specified size ① (into the drain plug hole)

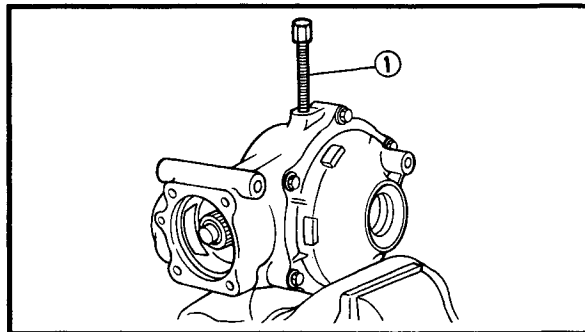

CAUTION:

Finger tighten the bolt until it holds the ring gear. Otherwise, the ring gear will be damaged.

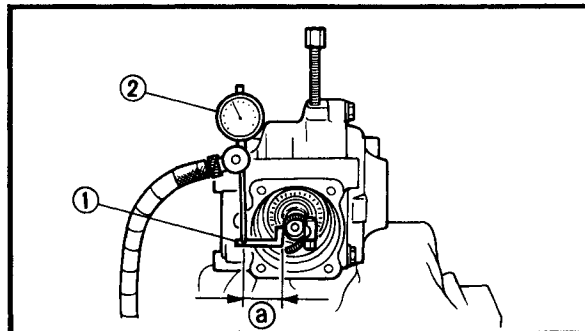

4. Attach:

- Gear lash measurement tool ①
- Dial gauge ②

	Gear lash measurement tool: P/N. YM-01467, 90890-01467
--	---

- ① Measuring point



5.Measure:

- Gear lash
Gently rotate the gear coupling from engagement to engagement.

	Differential gear lash: 0.05 ~ 0.25 mm (0.002 ~ 0.010 in)
--	---

NOTE: _____
 Measure the gear lash at four positions.
 Rotate the shaft 90° each time.

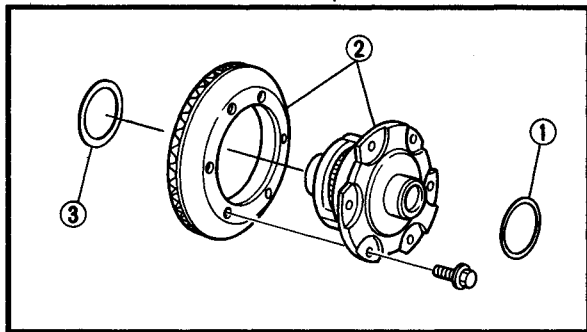

Differential gear lash adjustment

1.Remove:

- Shim(s) (left) ①
- Differential gear assembly ②
- Shim(s) (right) ③

2.Adjust:

- Gear lash

Gear lash adjustment steps:

- Select the suitable shims using the following chart.

Too-little gear lash	Reduce shim thickness.
Too-large gear lash	Increase shim thickness.

- If it is necessary to increase by more than 0.05 mm (0.002 in):
 Reduce right shim thickness by 0.1 mm (0.004 in) for every 0.1 mm (0.004 in) of left shim increase.
- If it is necessary to reduce by more than 0.1 mm (0.004 in):
 Increase right shim thickness by 0.1 mm (0.004 in) for every 0.1 mm of left shim decreased.



Ring gear shim (left and right)

Thickness (mm)	0.1	1.0
	0.2	1.5
	0.3	2.0
	0.4	2.5
	0.5	

DIFFERENTIAL GEAR OPERATION CHECK

1. Block the rear wheels, and elevate the front wheels by placing a suitable stand under the frame.
2. Remove the wheel cap and cotter pin from the axle nut (right or left).
3. Measure the starting torque of the front wheel (i.e., differential gear preload) with the torque wrench.

NOTE:

- Repeat this step several times to obtain an average figure.
- During this test, the other front wheel will turn in the opposite direction.

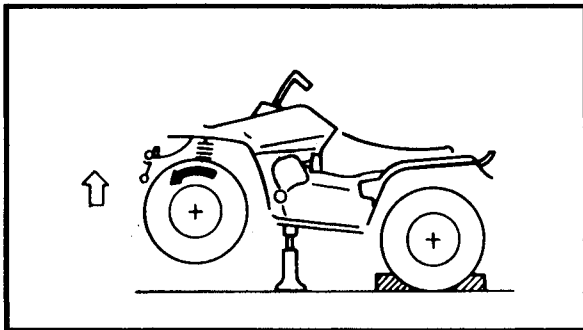

Front wheel starting torque:
(differential gear preload):

New unit:

17 ~ 25 Nm

(1.7 ~ 2.5 m · kg, 12 ~ 18 ft · lb)

Minimum:

10 Nm (1.0 m · kg, 7.2 ft · lb)

4. Out of specification, replace the differential gear assembly.
5. Within specification, install the new cotter pin and wheel cap.

REAR AXLE/FINAL DRIVE GEAR AND DRIVE SHAFT



REAR AXLE/FINAL DRIVE GEAR AND DRIVE SHAFT

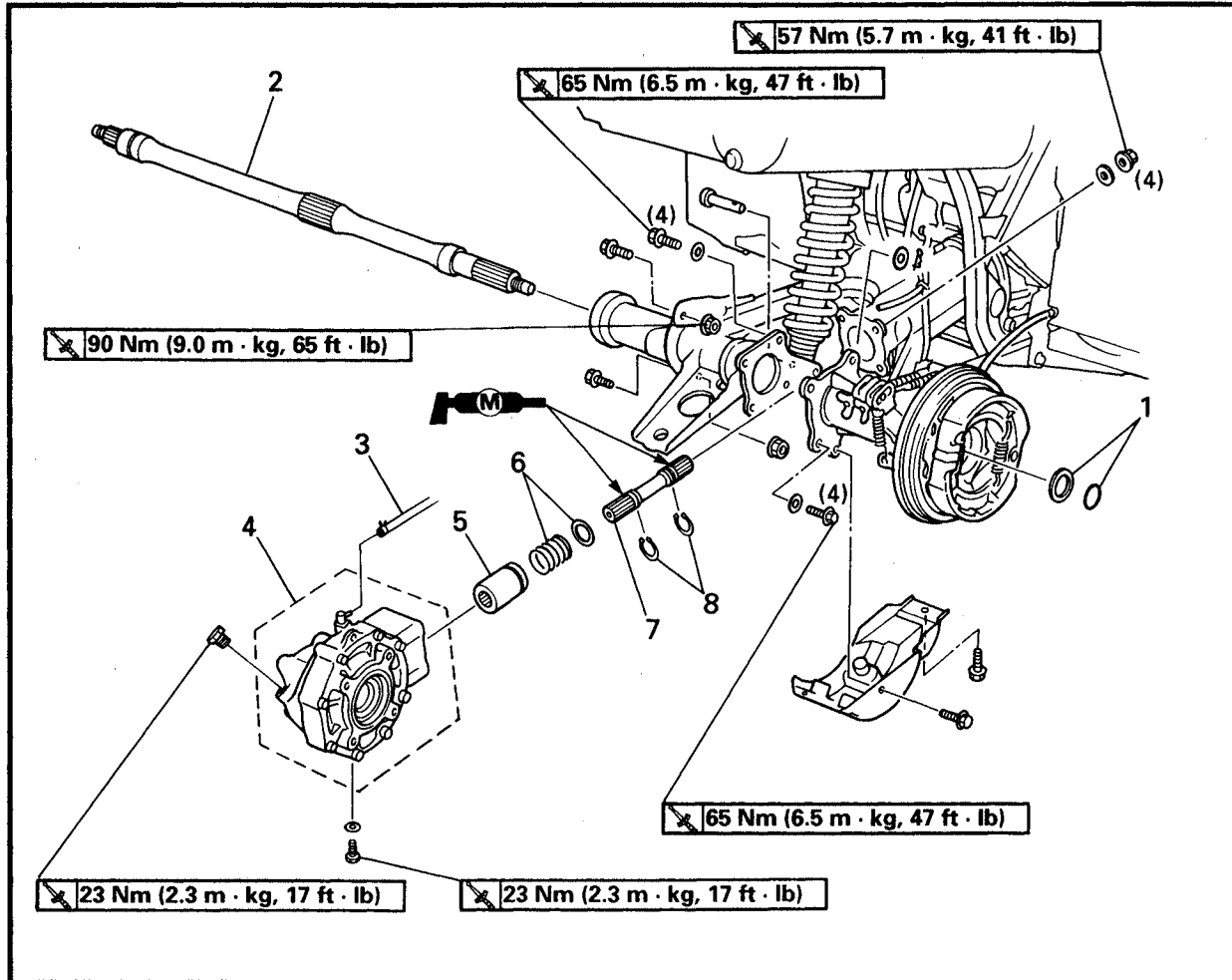

Order	Job name/Part name	Q'ty	Remarks
	Rear axle, final drive gear assembly and drive shaft removal		Remove the parts in the order below.
	Final gear oil		Drain
	Rear wheel/brake drum/wheel hub		Refer to "FRONT AND REAR WHEELS" in CHAPTER 7.
1	O-ring/washer	1/1] Refer to "REAR AXLE REMOVAL/INSTALLATION".
2	Rear axle	1	
3	Final drive gear breather hose	1	
4	Final drive gear	1	
5	Coupling gear	1	
6	Compression spring/washer	1/1	
7	Drive shaft	1	
8	Circlip	2	
			For installation, reverse the removal procedure.

REAR AXLE/FINAL DRIVE GEAR AND DRIVE SHAFT

DRIV

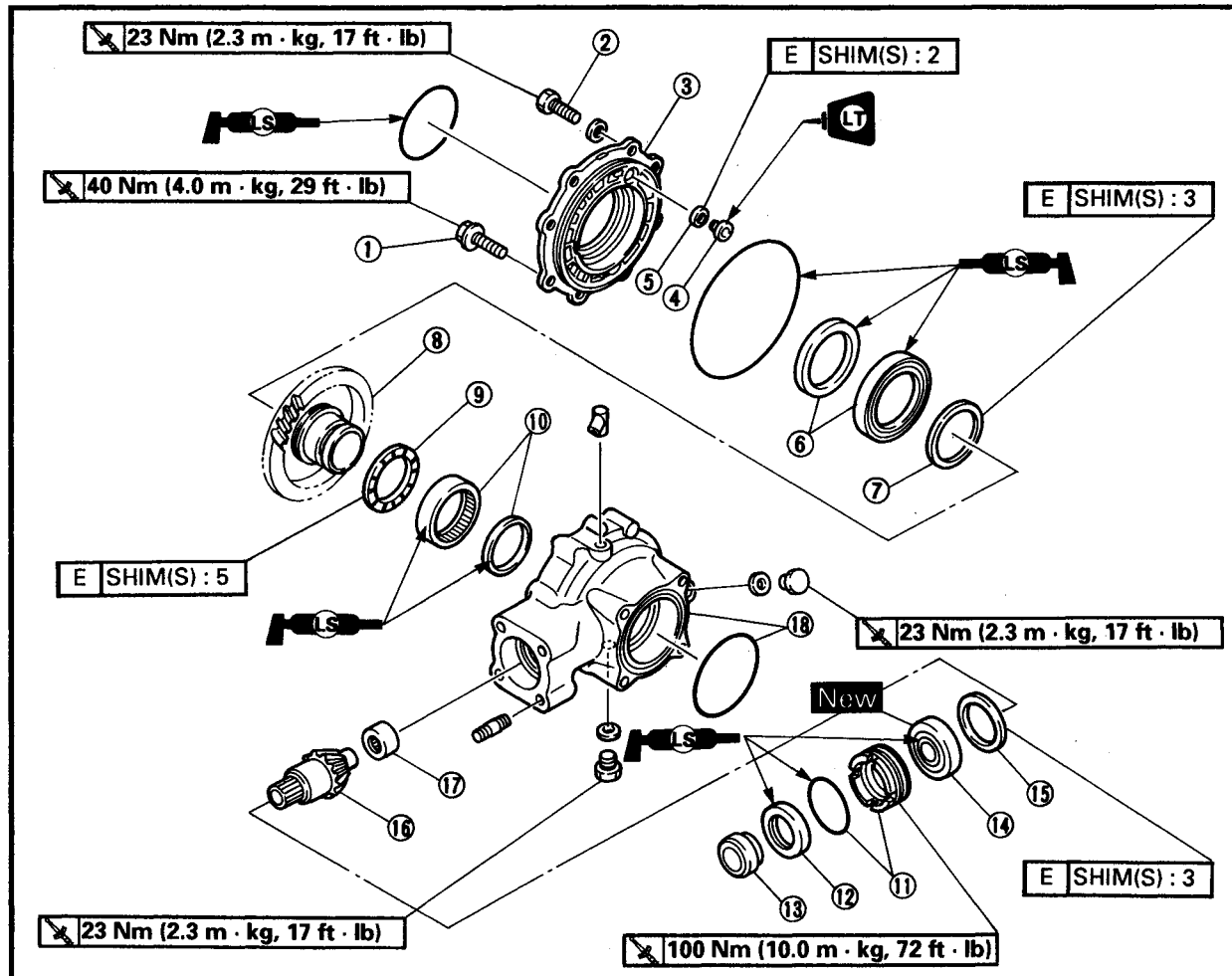

Order	Job name/Part name	Q'ty	Remarks
	Final drive gear disassembly		Disassemble the parts in the order below.
①	Bolt	2	NOTE: _____ Working in a crisscross pattern, loosen each bolt 1/4 of a turn. After all the bolts are loosened, remove them.
②	Bolt	6	
③	Bearing housing	1	
④	Ring gear stopper	1	
⑤	Ring gear stopper shim	1	
⑥	Oil seal/bearing	1/1	
⑦	Ring gear shim	1	
⑧	Ring gear	1	
⑨	Thrust washer	1	
⑩	Bearing/oil seat	1/1	
			Refer to "FINAL DRIVE ROLLER BEARING REMOVAL AND REASSEMBLY".

REAR AXLE/FINAL DRIVE GEAR AND DRIVE SHAFT

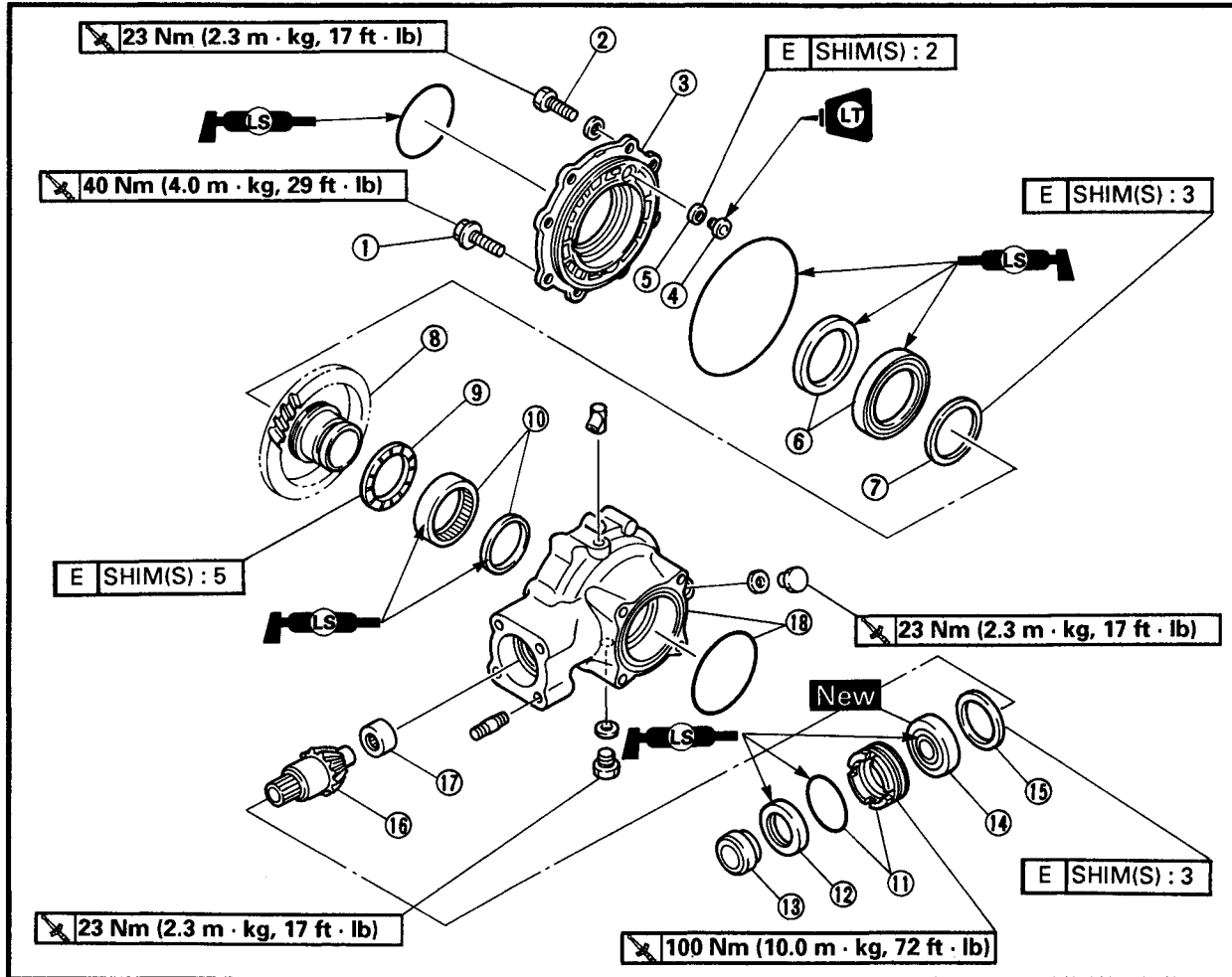

Order	Job name/Part name	Q'ty	Remarks
⑪	Bearing retainer/O-ring	1/1	Refer to "FINAL DRIVE GEAR DISASSEMBLY/ASSEMBLY".
⑫	Oil seat	1	
⑬	Collar	1	
⑭	Bearing	1	
⑮	Final drive pinion gear shim	1	
⑯	Final drive pinion gear	1	Refer to "FINAL DRIVE ROLLER BEARING REMOVAL/REASSEMBLY".
⑰	Bearing	1	
⑱	Final drive gear case/O-ring	1/1	For assembly, reverse the disassembly procedure.

REAR AXLE/FINAL DRIVE GEAR AND DRIVE SHAFT

DRIV

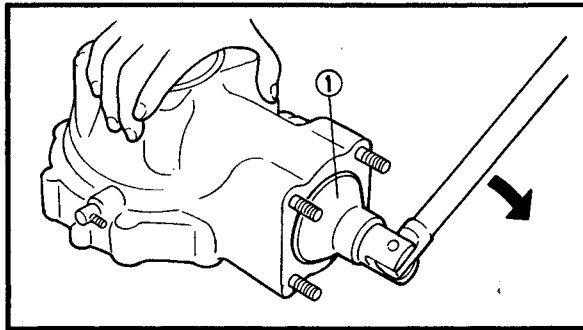
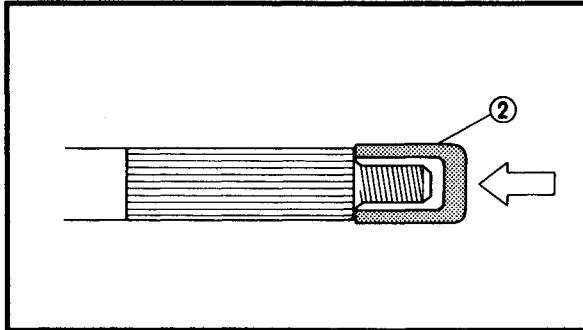
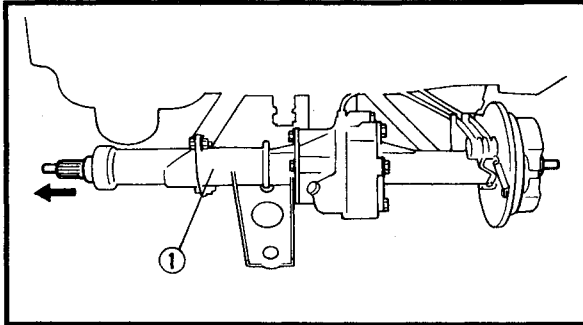

REAR AXLE REMOVAL

1.Remove:

- Rear axle ①
- O-ring
- Washer

CAUTION:

- Never directly tap the axle end with a hammer, this will result in damage to the axle thread and spline.
- Attach a suitable socket ② on the axle end and tap it with a soft hammer. Pull out the rear axle to the left.

FINAL DRIVE GEAR DISASSEMBLY

1.Remove:

- Bearing retainer (final drive pinion gear)

NOTE:

Use a bearing retainer wrench ①.



Bearing retainer wrench:
P/N. YM-04050, 90890-04050

CAUTION:

The final drive shaft bearing retainer has left-handed threads. To loosen the retainer turn it clockwise.

2.Remove:

- Final drive pinion gear assembly
With a soft hammer lightly tap on the final drive pinion gear end.

CAUTION:

Removal of the final drive pinion gear should only be performed if gear replacement is necessary.

⚠ WARNING

Always use new bearings and races.

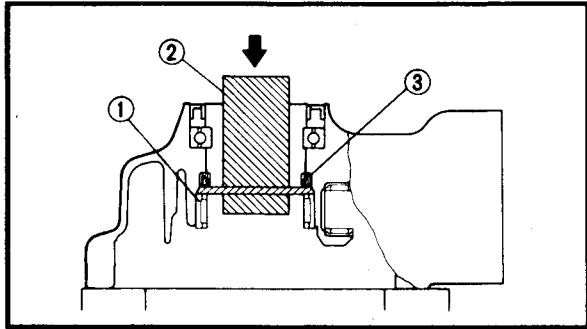

FINAL DRIVE ROLLER BEARING REMOVAL AND REASSEMBLY

1.Remove:

- Roller bearing (ring gear) ①
Use a suitable press tool ② and an appropriate support for the main housing.
- Oil seal ③

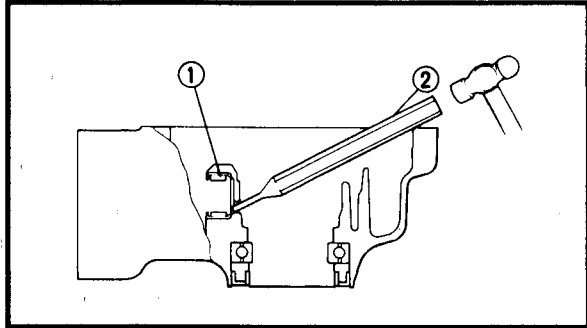

2.Remove:

- Roller bearing (final drive pinion gear) ①

Removal steps:

- Heat the main housing only to 150°C (302°F).
- Remove the roller bearing outer race with an appropriately shaped punch ②.
- Remove the inner race from the final drive pinion gear.

NOTE:

The removal of the final drive pinion gear roller bearing is difficult and seldom necessary.

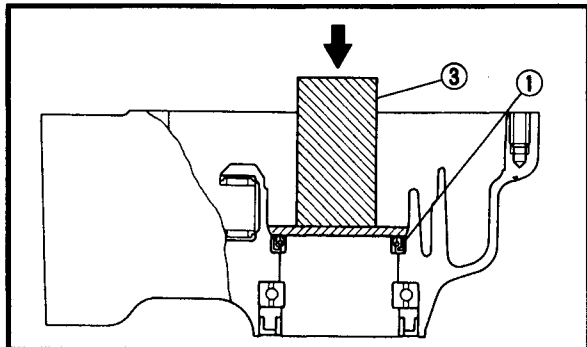

3.Install:

- Roller bearing (Final drive pinion gear) **New**

Installation steps:

- Heat the main housing only to 150°C (302°F).
- Install the roller bearing outer race using the proper adapter.
- Install the inner race onto the drive pinion gear.

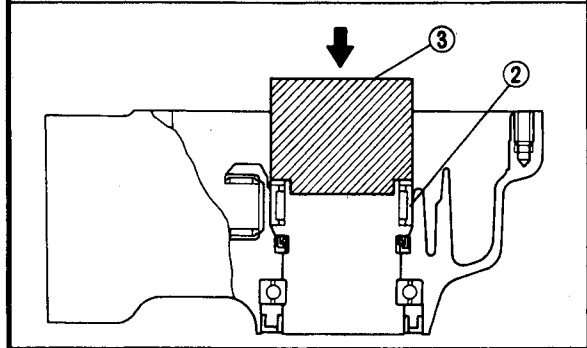

4.Install:

- Oil seal ① **New**
- Roller bearing ②
Use a suitable press tool ③ and a press to install the above components into the main housing.



FINAL DRIVE PINION GEAR AND RING GEAR POSITIONING

When the final drive pinion gear, ring gear, final gear case and/or ring gear bearing housing are replaced, be sure to adjust the positions of the final drive pinion gear and ring gear using the shim(s).

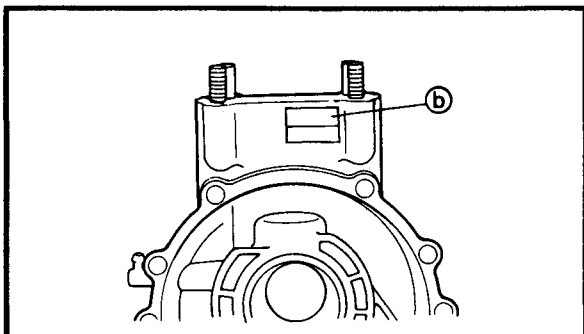
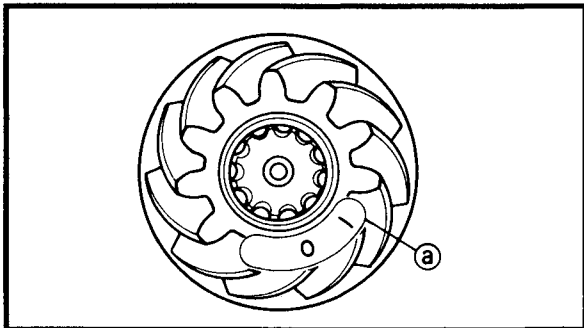
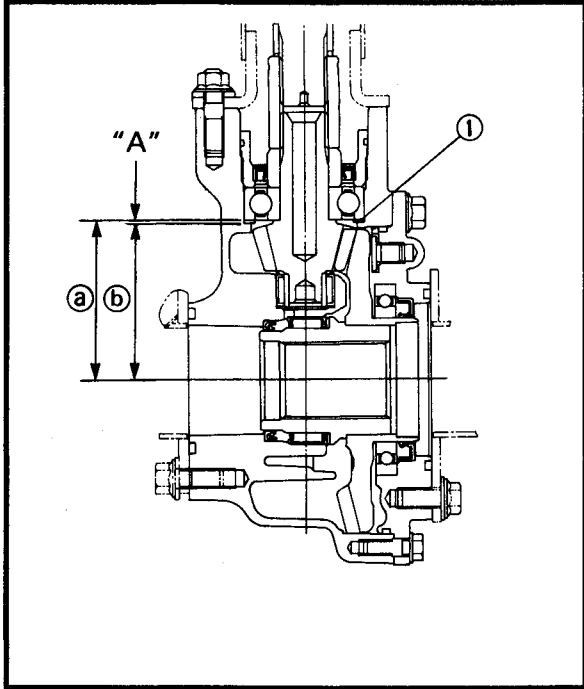

Final drive pinion gear shim(s) selection

1. Select:

- Final drive pinion gear shim(s) ①

Shim selection steps:

- To find the final drive pinion gear shim thickness "A", use the following formula.

Final drive pinion gear shim thickness:

$$"A" = \textcircled{a} - \textcircled{b}$$

- ① = a numeral (usually a decimal number) on the final drive pinion gear is either added to or subtracted from "84".
- ② = a numeral (usually a decimal number) on the final gear case is either added to or subtracted from "83".

Example:

- 1) If the "01" is stamped on the final drive pinion gear,
 $\textcircled{a} = 84 + 0.01 = 84.01$
- 2) If the "50" is stamped on the final gear case,
 $\textcircled{b} = 83 + 0.50 = 83.50$
- 3) Therefore, "A" is 0.51.
 $"A" = 84.01 - 83.50 = 0.51$
- 4) Round off the hundredths digit and select the appropriate shim(s).
 In the example above, the calculated number is 0.51. The chart instructs you to round off 1 to 0 at the hundredth place. Thus, the shim thickness is 0.50 mm.

Hundredths	Rounded value
0, 1, 2, 3, 4	0
5, 6, 7, 8, 9	10



Shims are supplied in the following thicknesses.

	Final drive pinion gear shim	
Thickness (mm)	0.30	0.50
	0.40	

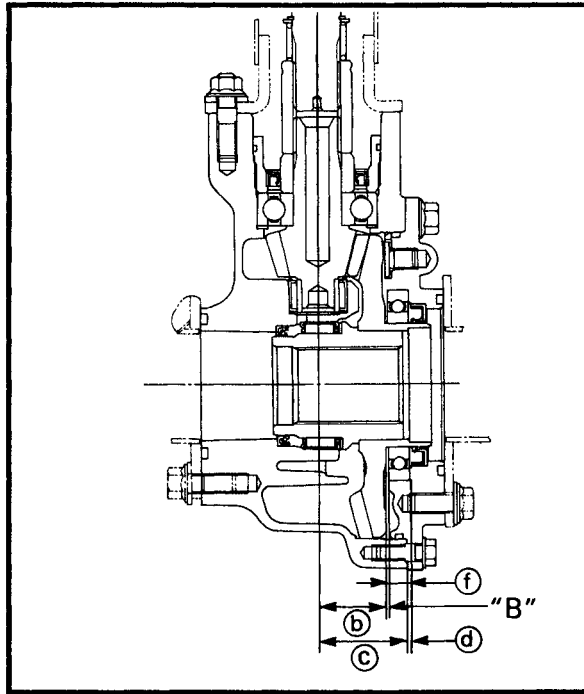

Ring gear shim(s) selection

1. Select:

- Ring gear shim(s) ①

Shim selection steps:

- To find ring gear shim thickness "B", use the following formula.

<p>Ring gear shim thickness: "B" = c + d - (e + f)</p>

- ⓐ = a numeral (usually a decimal number) on the final gear case is either added to or subtracted from 45.
- ⓓ = a numeral (usually a decimal number) on outside of ring gear bearing housing and added to 1.
- ⓔ = a numeral (usually a decimal number) on inside of ring gear either added to or subtracted from 35.00.
- ⓕ = bearing thickness (considered constant).

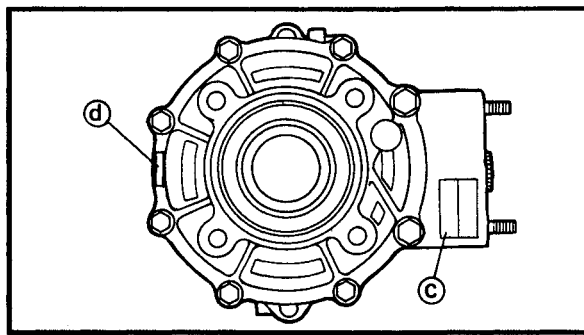

<p> Bearing thickness ①: 11.00 mm</p>
--

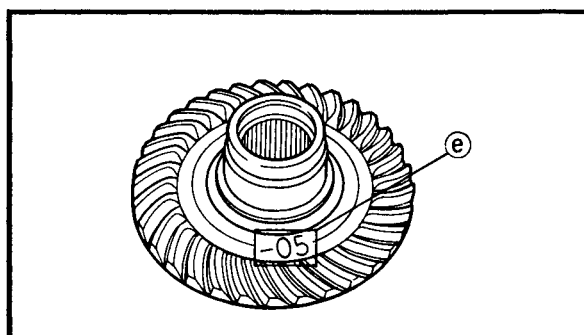

Example:

- 1) If "53" is stamped on the final gear case,
 $c = 45 + 0.53 = 45.53$
- 2) If "05" is stamped on the ring gear bearing housing,
 $d = 1 + 0.05 = 1.05$
- 3) If "-05" is stamped on the ring gear,
 $e = 35 - 0.05 = 34.95$
- 4) ⓕ = is 11.00.



- 5) Therefore, shim thickness "B" is,
 $B = 45.53 + 1.05 - (34.95 + 11.00)$
 $= 46.58 - 45.95$
 $= 0.63$

- 6) Round off the hundredths digit and select the appropriate shim(s).
 In the example above, the calculated number is 0.63. The chart instructs you to round off 3 to 5 at the hundredth place.
 Thus, the shim thickness is 0.65 mm.

Hundredths	Rounded value
0, 1, 2	0
3, 4, 5, 6, 7	5
8, 9	10

Shims are supplied in the following thicknesses.

 Ring gear shim			
Thickness (mm)	0.25	0.30	0.40
	0.50		

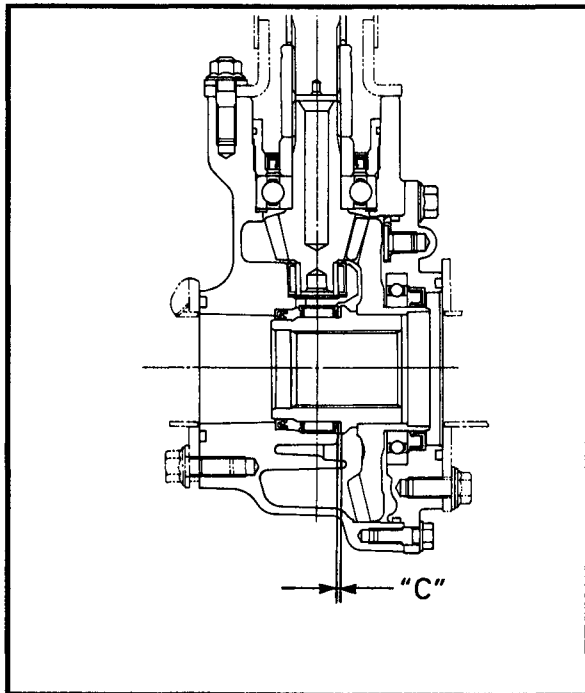

Thrust washer selection

1.Measure/select:

- Ring gear thrust clearance "C"

Thrust clearance measurement steps:

- Place four pieces of Plastigauge® between the originally fitted thrust washer and the ring gear.
- Install the ring gear assembly and tighten the bolts to specification.

	M8 Bolts (bearing housing):
	23 Nm (2.3 m • kg, 17 ft • lb)
	M10 Bolts (bearing housing):
	40 Nm (4.0 m • kg, 29 ft • lb)

NOTE: _____
 Do not turn the drive pinion gear and ring gear when measuring the clearance with Plastigauge®.

REAR AXLE/FINAL DRIVE GEAR AND DRIVE SHAFT

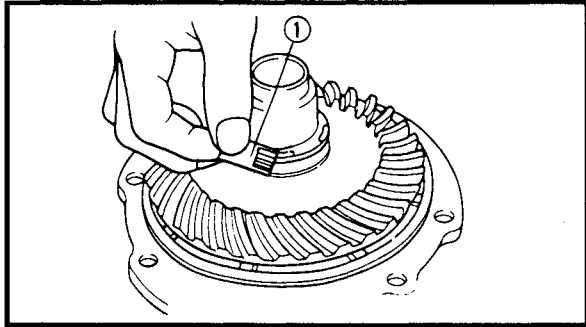

- Remove the ring gear assembly.
- Measure the thrust clearance. Calculate the width of the flattened Plastigauge® ①.

	Ring gear thrust clearance: 0.1 ~ 0.2 mm (0.004 ~ 0.008 in)
--	---

- If out of specification, select the correct washer.

Thrust washer selection steps:

- Select a suitable thrust washer using the following chart.

	Thrust washer		
Thickness (mm)	1.2 1.8	1.4 2.0	1.6

- Repeat the measurement steps until the ring gear thrust clearance is within the specified limits.

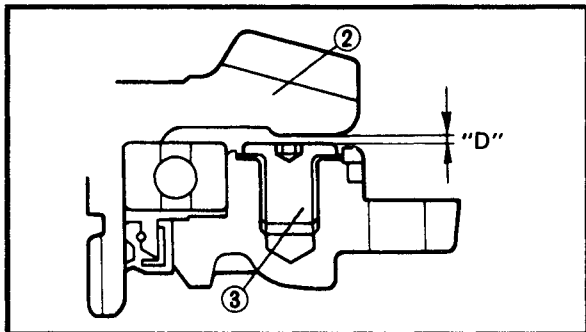

Ring gear stopper shim selection

1. Measure:

- Ring gear stopper clearance "D"
Use a feeler gauge ①.
Out of specification → Adjust.

	Ring gear stopper clearance "D": 0.30 ~ 0.60 mm (0.012 ~ 0.024 in)
--	--

- ② Ring gear
- ③ Ring gear stopper

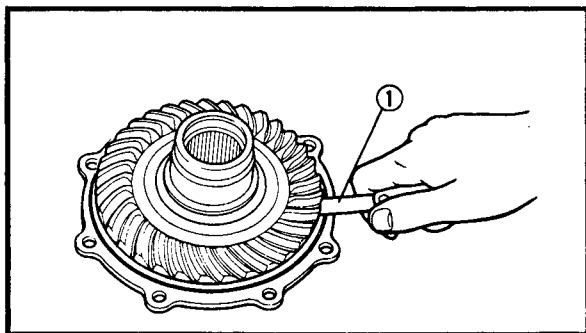

REAR AXLE/FINAL DRIVE GEAR AND DRIVE SHAFT

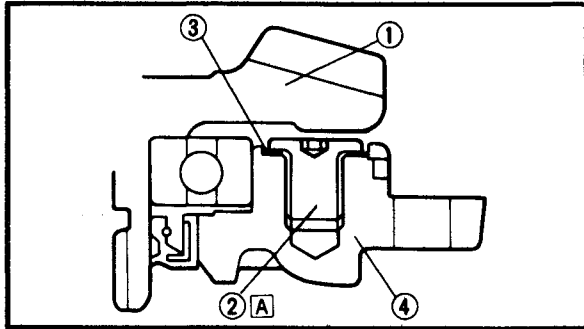

Ring gear stopper clearance adjustment

- 1.Remove:
- Ring gear ①
 - Ring gear stopper ②
 - Shim(s) ③
 - ④ Bearing housing
 - ⓐ Left-hand threads

- 2.Select:
- Suitable shim(s)

	Shim	
Thickness (mm)	0.15	0.20

- 3.Install:
- Shim(s)
 - Ring gear stopper (left-hand threads)

9 Nm (0.9 m · kg, 6.5 ft · lb)

- Ring gear

NOTE: _____
Use LOCTITE® on the ring gear stopper.

- 4.Measure:
- Ring gear stopper clearance
 - Out of specification → Repeat.

Ring gear stopper clearance:
0.30 ~ 0.60 mm (0.012 ~ 0.024 in)

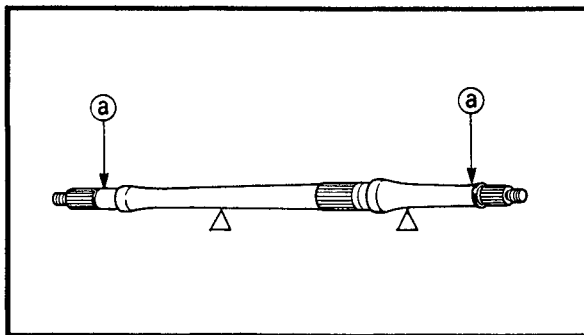

REAR AXLE INSPECTION

- 1.Inspect:
- Rear axle runout ⓐ
 - Out of specification → Replace.

⚠ WARNING _____
Do not attempt to straighten a bent axle.

Rear axle runout limit:
1.5 mm (0.06 in)

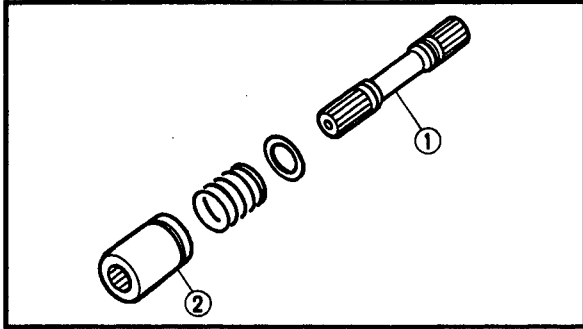

DRIVE SHAFT INSPECTION

1. Inspect:

- Drive shaft (splines) ①
 - Coupling gear (splines) ②
- Wear/damage → Replace.

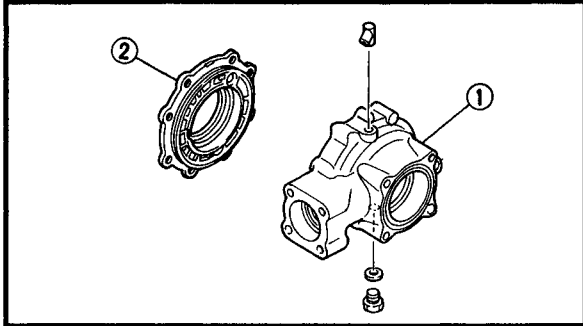

FINAL DRIVE GEAR INSPECTION

1. Inspect:

- Final gear case ①
 - Bearing housing (ring gear) ②
- Cracks/damage → Replace.

NOTE:

When the final gear case and/or the ring gear bearing housing are replaced, be sure to adjust the shim of the final drive pinion gear and/or ring gear.

2. Inspect:

- Gear teeth
- Pitting/galling/wear → Replace the drive pinion gear and ring gear as a set.
- Oil seals
 - O-rings
- Damage → Replace.

3. Inspect:

- Bearings
- Damage → Replace.

NOTE:

- Reusing roller bearings is acceptable, but Yamaha recommends installing new ones. Do not reuse the oil seal.
- When the final drive pinion gear and/or ring gear are replaced, be sure to adjust the shim of the final drive pinion gear and/or ring gear.

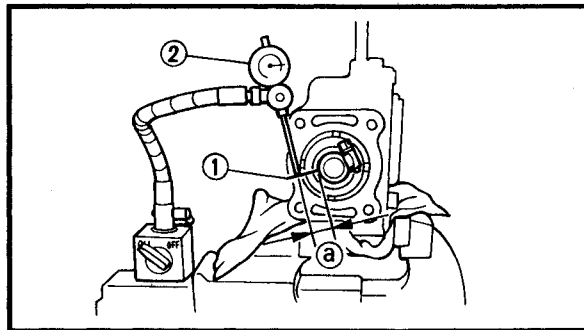
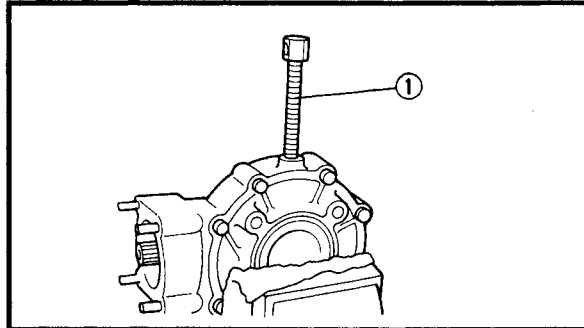
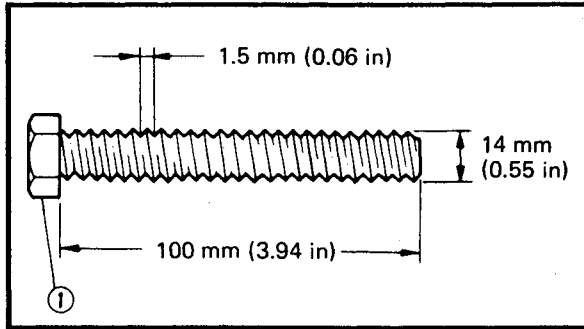

FINAL GEAR LASH MEASUREMENT AND ADJUSTMENT

Final gear lash measurement

1. Secure the gear case in a vise or another supporting device.
2. Remove:
 - Drain plug
 - Gasket
3. Install:
 - A bolt of the specified size ① (into the drain plug hole)

CAUTION: Finger tighten the bolt until it holds the ring gear. Otherwise, the ring gear will be damaged.

4. Attach:
 - Gear lash measurement tool ①
 - Dial gauge ②

 **Gear lash measurement tool:**
P/N. YM-01231, 90890-01231

ⓐ Measuring point

5. Measure:
 - Gear lash

Gently rotate the gear coupling from engagement to engagement.

 **Final gear lash:**
0.1 ~ 0.2 mm (0.004 ~ 0.008 in)

NOTE: Measure the gear lash at four positions. Rotate the shaft 90° each time.

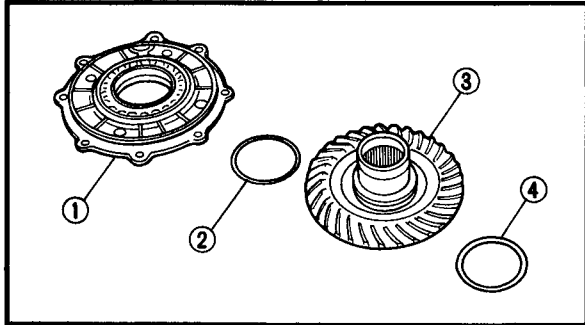

Final gear lash adjustment

1.Remove:

- Bearing housing ①
- Ring gear shim(s) ②
- Ring gear ③
- Thrust washer ④

2.Adjust:

- Gear lash

Adjustment steps:

- Select a suitable shim(s) and thrust washer(s) using the following chart.

Too-little gear lash	Reduce shim thickness.
Too-large gear lash	Increase shim thickness.

- If increased by more than 0.2 mm (0.008 in):

Reduce the thrust washer thickness by 0.2 mm (0.008 in) for every 0.2 mm of ring gear shim increase.

- If reduced by more than 0.2 mm (0.008 in): Increase the thrust washer thickness by 0.2 mm (0.008 in) for every 0.2 mm that the ring gear shim is decreased.

	Ring gear shim		
Thickness (mm)	0.25	0.30	0.40
	0.50		

	Thrust washer		
Thickness (mm)	1.2	1.4	1.6
	1.8	2.0	

REAR AXLE/FINAL DRIVE GEAR AND DRIVE SHAFT

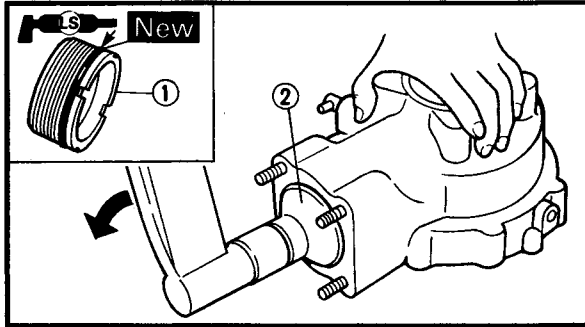

FINAL DRIVE GEAR ASSEMBLY

1.Install:

- Drive pinion gear (with shim(s) and bearing)
- Shim(s) → (proper size as calculated)
- Bearing retainer (drive pinion gear) ①

100 Nm (10.0 m · kg, 72 ft · lb)

Use a bearing retainer wrench ②.

CAUTION:

- Always use a new bearing.
- The final drive shaft bearing retainer has left-hand threads. Turn the retainer counterclockwise to tighten it.



Bearing retainer wrench:
P/N. YM-04050, 90890-04050

2.Adjust:

- Final gear lash
Refer to "FINAL GEAR LASH MEASUREMENT AND ADJUSTMENT".

REAR AXLE INSTALLATION

1.Install:

- Rear axle

Installation steps:

- Check if the brake shoe assembly is installed on the swingarm. If the brake shoe assembly is not installed, refer to "REAR BRAKE" for installation instructions.
- Check that the final gear case and rear axle housing have been removed from the swingarm. If the final gear case and rear axle housing are still installed, remove them.
- Apply sealant (Quick Gasket®) to the mating surfaces of the swingarm and the final drive gear.

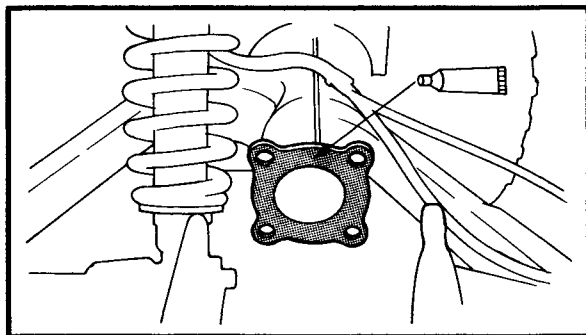

Quick gasket®:
ACC-11001-05-01
Yamaha bond No. 1215®:
90890-85505

REAR AXLE/FINAL DRIVE GEAR AND DRIVE SHAFT

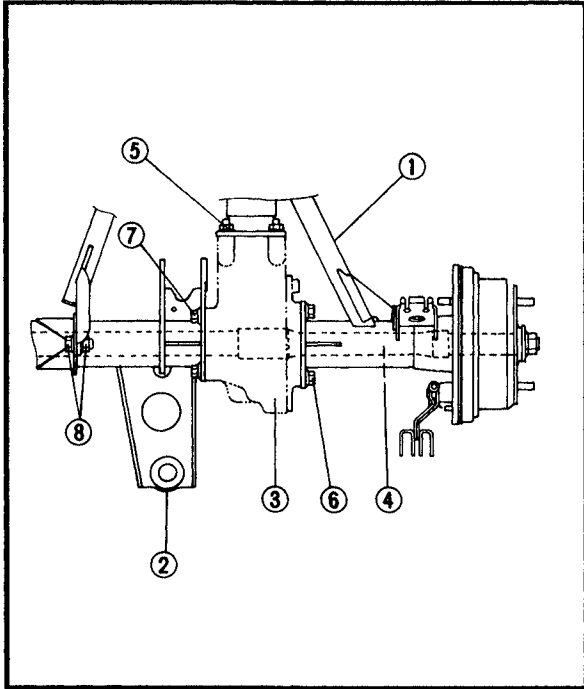
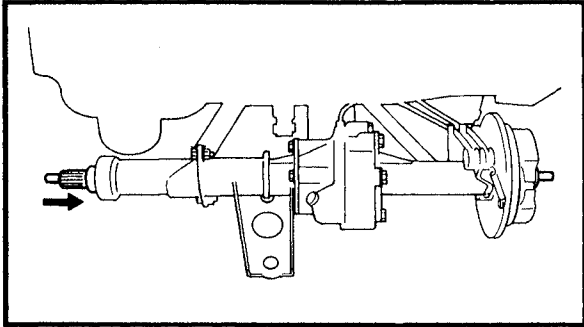

- Temporarily install the rear axle housing ② and final drive gear ③ on the swingarm ①. The bolts and nuts ⑤ ~ ⑧ should be temporarily tightened in the specified order.
- Install the rear axle ④ from the left side of the machine.
- Install the brake drum.



Axle nut:
150 Nm (15.0 m · kg, 110 ft · lb)

Refer to "FRONT AND REAR WHEELS" in CHAPTER 7.

- Check that the rear axle ④ rotates smoothly.
- Tighten the bolts and nuts ⑤ ~ ⑧ in the specified order.

- ① Swingarm
- ② Rear axle housing
- ③ Final drive gear
- ④ Rear axle
- ⑤ Nut (x4)
- ⑥ Bolt (x4)
- ⑦ Bolt (x4)
- ⑧ Bolt/nut (x2)



Nut ⑤:
57 Nm (5.7 m · kg, 41 ft · lb)
Bolt ⑥, ⑦:
65 Nm (6.5 m · kg, 47 ft · lb)
LOCTITE®
Nut ⑧:
90 Nm (9.0 m · kg, 65 ft · lb)

CHASSIS

FRONT AND REAR WHEELS

FRONT WHEELS

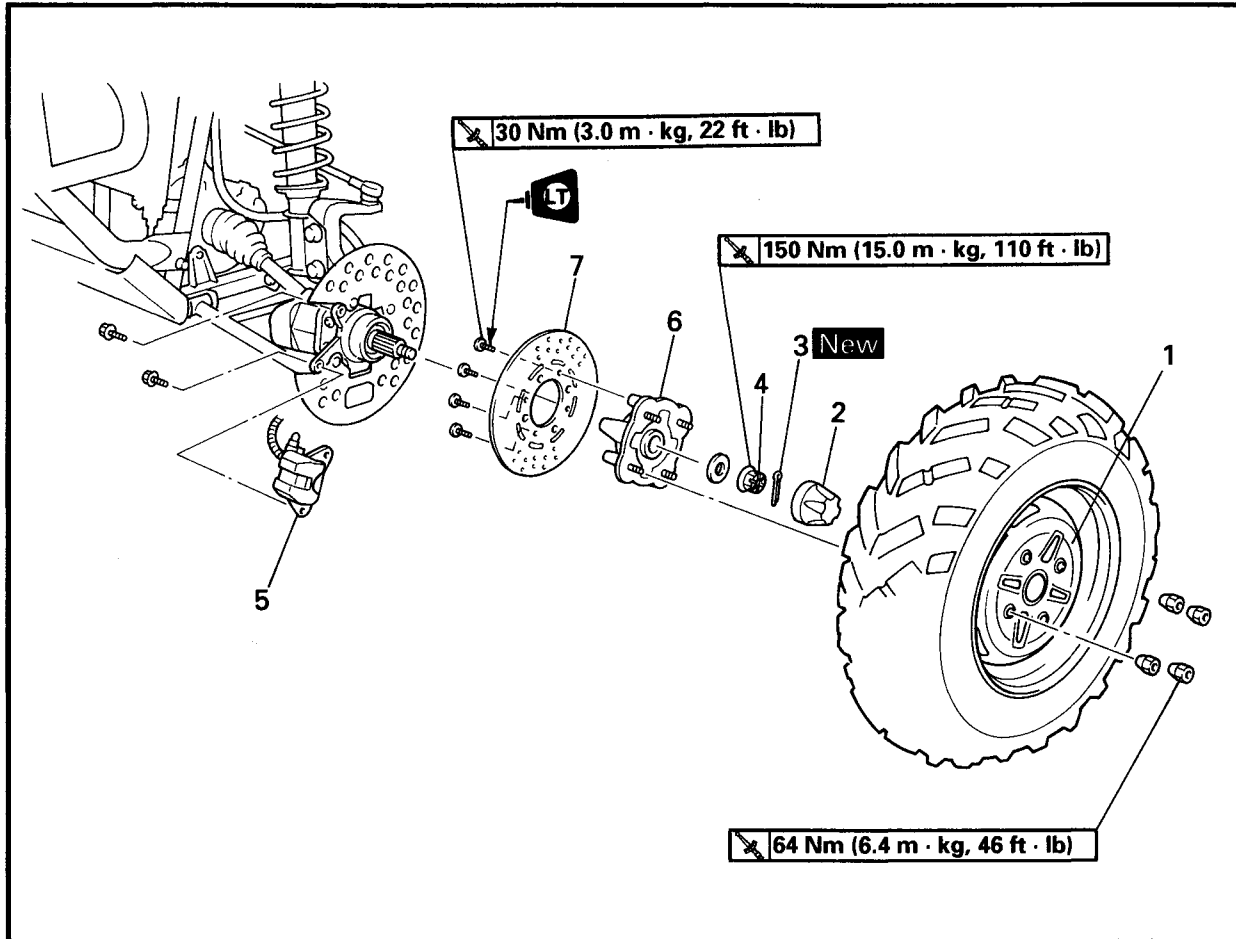

Order	Job name/Part name	Q'ty	Remarks
	Front wheel removal		Remove the parts in the order below. Place the machine on a level surface.
			⚠ WARNING _____ Securely support the machine so there is no danger of it falling over.
1	Front wheel	1	Refer to "WHEEL INSTALLATION".
2	Wheel cap	1	Refer to "WHEEL HUB/BRAKE DRUM INSTALLATION".
3	Cotter pin	1	
4	Axle nut	1	
5	Brake caliper assembly	1	NOTE: _____ Do not squeeze the brake lever when the brake caliper is off of the brake disc as the brake pads will be forced shut.
6	Wheel hub	1	
7	Brake disc	1	
			For installation, reverse the removal procedure.

REAR WHEELS

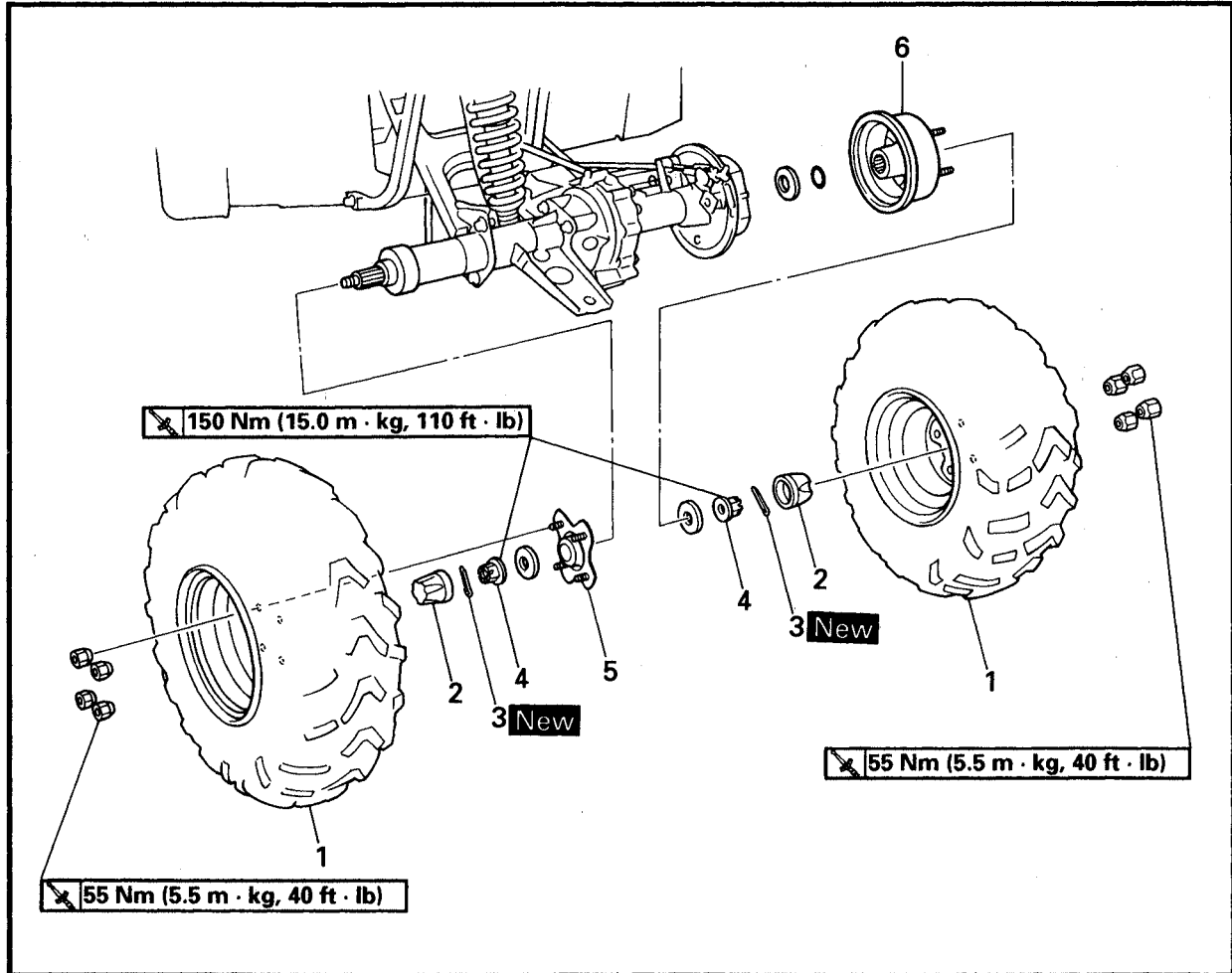

Order	Job name/Part name	Q'ty	Remarks
	Rear wheel removal		Remove the parts in the order below. Place the machine on a level surface. ⚠ WARNING Securely support the machine so there is no danger of it falling over.
1	Rear wheel	2	Refer to "WHEEL INSTALLATION".
2	Wheel cap	2	
3	Cotter pin	2	Refer to "WHEEL HUB/BRAKE DRUM INSTALLATION".
4	Axle nut	2	
5	Wheel hub	1	
6	Brake drum	1	For installation, reverse the removal procedure.

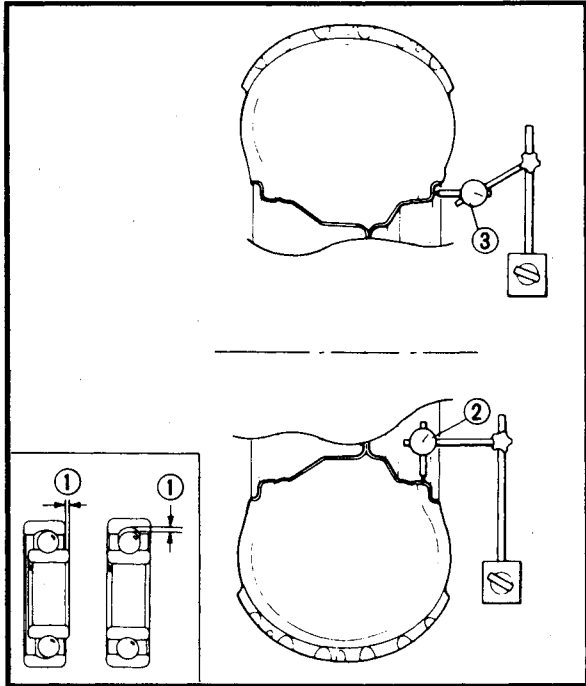

WHEEL INSPECTION

1. Inspect:
 - Wheel
2. Measure:
 - Wheel runout
 - Over the specified limit → Replace the wheel or check the front wheel bearing play ①.



Rim runout limit:
 Radial ②: 2.0 mm (0.08 in)
 Lateral ③: 2.0 mm (0.08 in)

3. Check:
 - Wheel balance
 - Out of balance → Adjust.

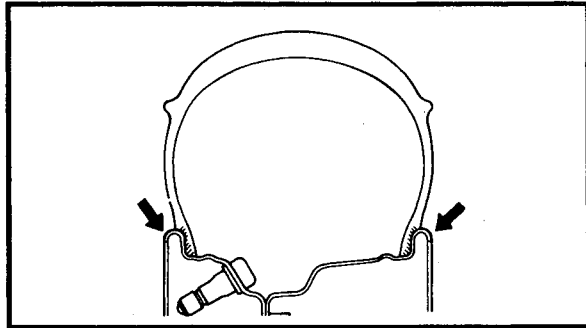

⚠ WARNING

After replacing the tire, ride conservatively to allow the tire to be properly seated in the rim. Failure to do so may cause an accident resulting in machine damage and possible operator injury.

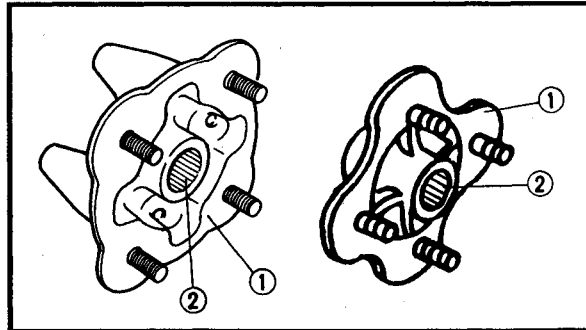

WHEEL HUB INSPECTION

1. Inspect:
 - Wheel hub ①
 - Cracks/damage → Replace.
 - Splines (wheel hub) ②
 - Wear/damage → Replace.

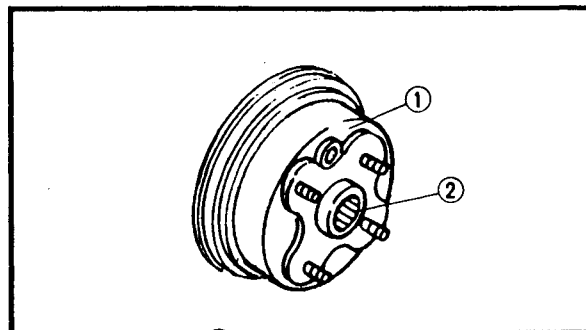

BRAKE DRUM INSPECTION

1. Inspect:
 - Brake drum ①
 - Cracks/damage → Replace.
 - Splines (wheel drum) ②
 - Wear/damage → Replace.

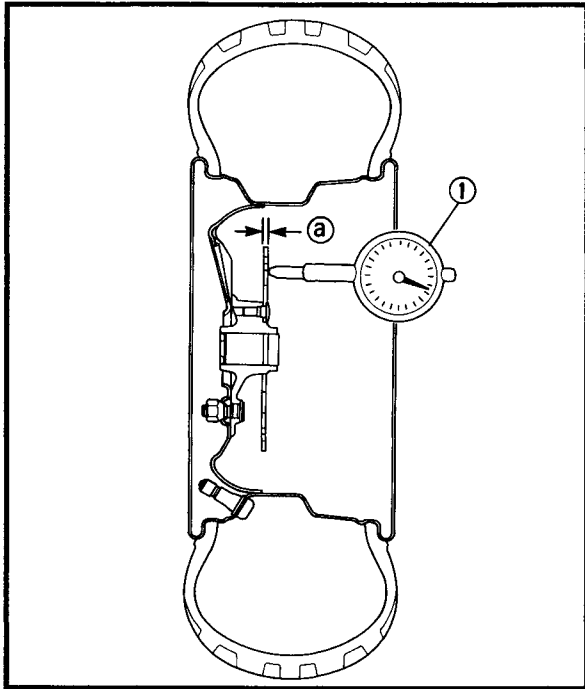

BRAKE DISK INSPECTION

1. Inspect:
 - Brake disc
 - Galling/damage → Replace.
2. Measure:
 - Brake disc deflection
 - Out of specification → Inspect the wheel runout.
 - If wheel runout is within the limits, replace the brake disc.

 **Brake disc maximum deflection:**
0.15 mm (0.006 in)

- Brake disc thickness **a**
 - Out of specification → Replace.

 **Brake disc minimum thickness:**
3 mm (0.12 in)

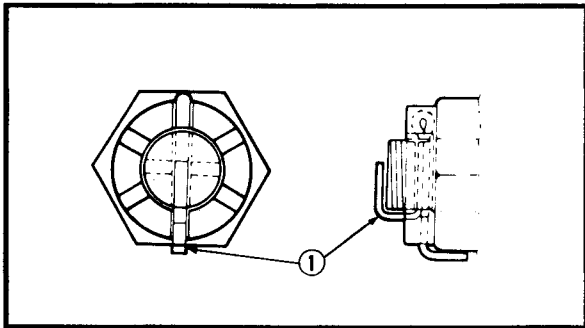

WHEEL HUB/BRAKE DRUM INSTALLATION

1. Install:
 - Cotter pin **1** **New**

NOTE: _____
Do not loosen the axle nut after torquing it. If the axle nut groove is not aligned with the cotter pin hole, align the groove with the hole by tightening the axle nut.

2. Adjust:
 - Front brake free play
 - Refer to "FRONT BRAKE ADJUSTMENT" in CHAPTER 3.
 - Rear brake lever and pedal free play
 - Refer to "REAR BRAKE LEVER AND PEDAL ADJUSTMENT" in CHAPTER 3.

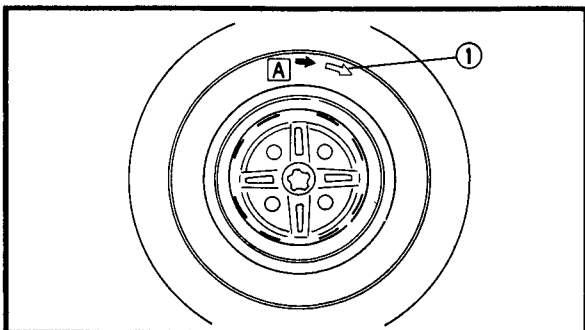

WHEEL INSTALLATION

1. Install:
 - Wheel

NOTE: _____
The arrow mark **1** on the tire must point in the direction of rotation **A** of the wheel.

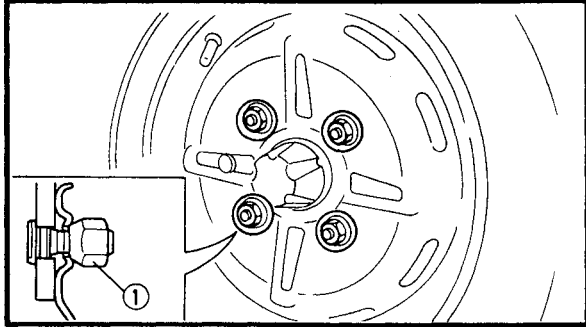

2.Tighten:

- Nuts (wheel) ①

⚠ WARNING

Tapered wheel nuts ① are used for both the front and rear wheels. Install the nut with its tapered side towards the wheel.

**FRONT BRAKE
BRAKE PADS**

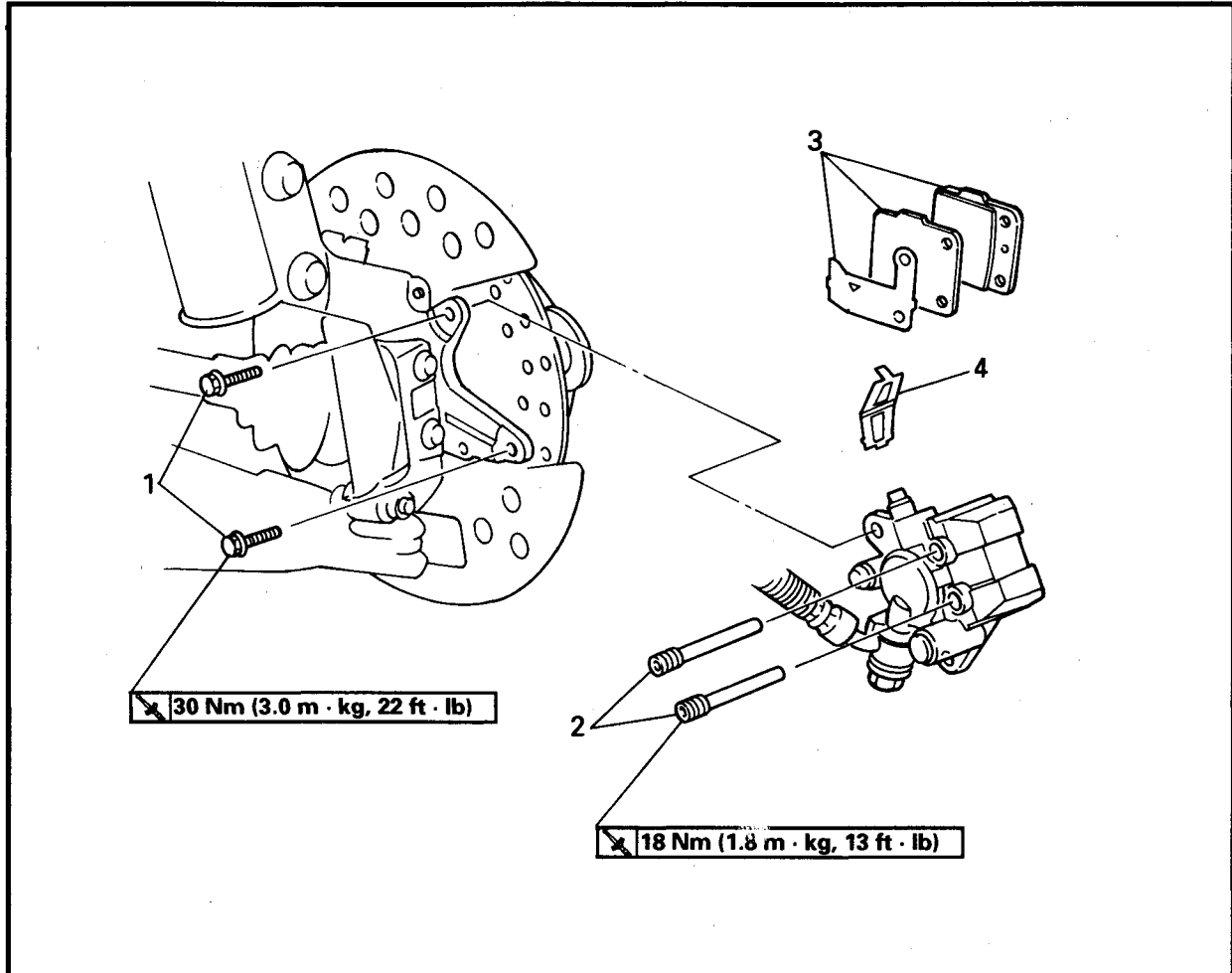

Order	Job name/Part name	Q'ty	Remarks
	Brake pad removal Front wheel		Remove the parts in the order below. Refer to "FRONT AND REAR WHEELS".
1	Brake caliper mounting bolt	2	Refer to "BRAKE PAD REPLACEMENT".
2	Brake pad holding bolt	2	
3	Brake pad/pad shim	2/1	
4	Pad spring	1	
			For installation, reverse the removal procedure.

CAUTION:

Disc brake components rarely require disassembly. DO NOT:

- disassemble components unless absolutely necessary;
- use solvents on internal brake components;
- use spent brake fluid for cleaning; (use only clean brake fluid)
- allow brake fluid to come in contact with the eyes, as this may cause eye injury;
- splash brake fluid onto painted surfaces or plastic parts, as this may cause damage;
- disconnect any hydraulic connection, as this would require the entire brake system to be disassembled, drained, cleaned, properly filled and bled after reassembly.

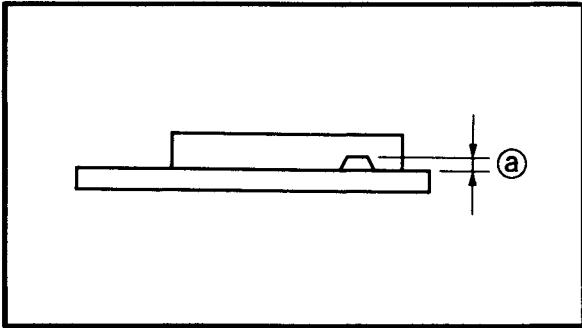

BRAKE PAD REPLACEMENT

NOTE:

It is not necessary to disassemble the brake caliper and brake hose to replace the brake pads.

1. Remove:

- Brake pads
- Ⓐ Wear limit

NOTE:

- Install new brake pad spring when the brake pads have to be replaced.
- Replace the brake pads as a set if either is found to be worn to the wear limit.

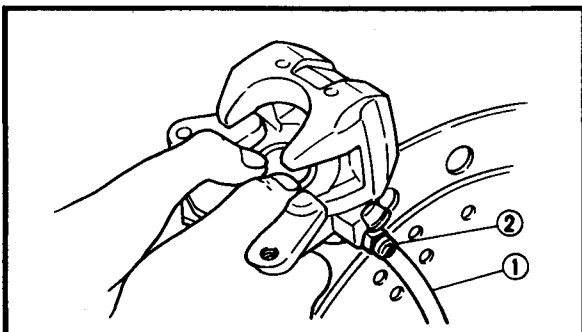

2. Install:

- Brake pads
- Brake pad spring

Installation steps:

- Connect a suitable hose ① tightly to the brake caliper bleed screw ②. Put the other end of this hose into an open container.



- Loosen the brake caliper bleed screw and using a finger push the caliper piston into the brake caliper.
- Tighten the brake caliper bleed screw.



Brake caliper bleed screw:
6 Nm (0.6 m · kg, 4.3 ft · lb)

- Install new brake pads, new pad shim ③ and a new brake pad spring.
- Install the retaining bolts and brake caliper.

NOTE:

The arrow mark ④ on the pad shim must point in the direction of the disc rotation.

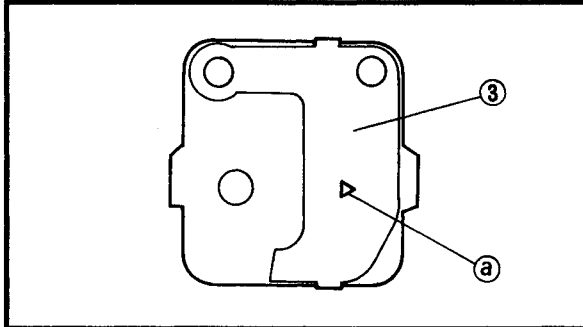

Brake pad holding bolt:
18 Nm (1.8 m · kg, 13 ft · lb)
Brake caliper mounting bolt:
30 Nm (3.0 m · kg, 22 ft · lb)

3. Inspect:

- Brake fluid level
Refer to "BRAKE FLUID INSPECTION" in CHAPTER 3.

4. Check:

- Brake lever operation
Soft or spongy feeling → Bleed the brake system.
Refer to "AIR BLEEDING (HYDRAULIC BRAKE SYSTEM)" in CHAPTER 3.

MASTER CYLINDER

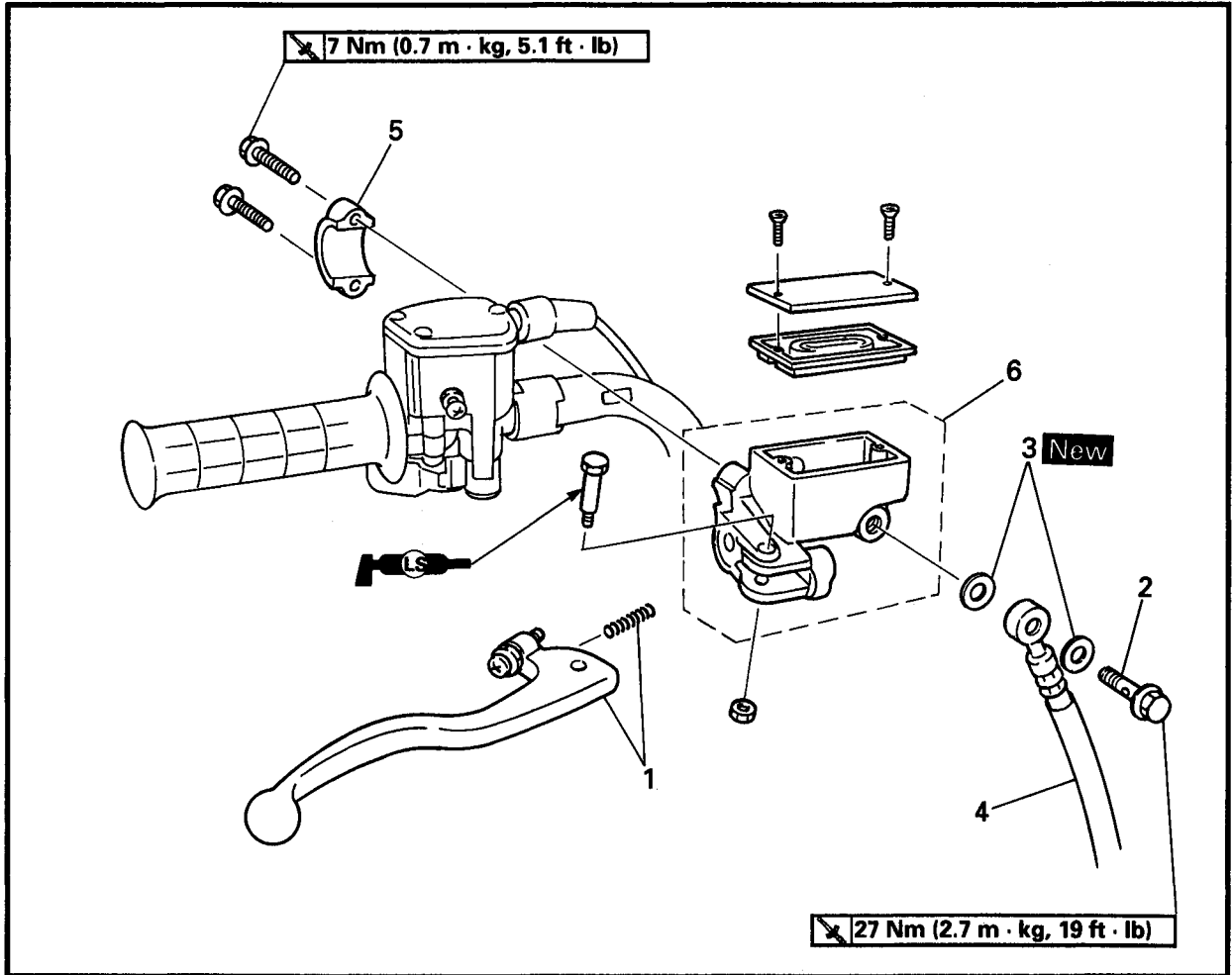

Order	Job name/Part name	Q'ty	Remarks
	Master cylinder removal		Remove the parts in the order below.
	Brake fluid		Drain
1	Brake lever/compression spring	1/1	
2	Union bolt	1	
3	Copper washer	2	
4	Brake hose	1	Refer to "MASTER CYLINDER INSTALLATION".
5	Master cylinder bracket	1	
6	Master cylinder	1	
			For installation, reverse the removal procedure.

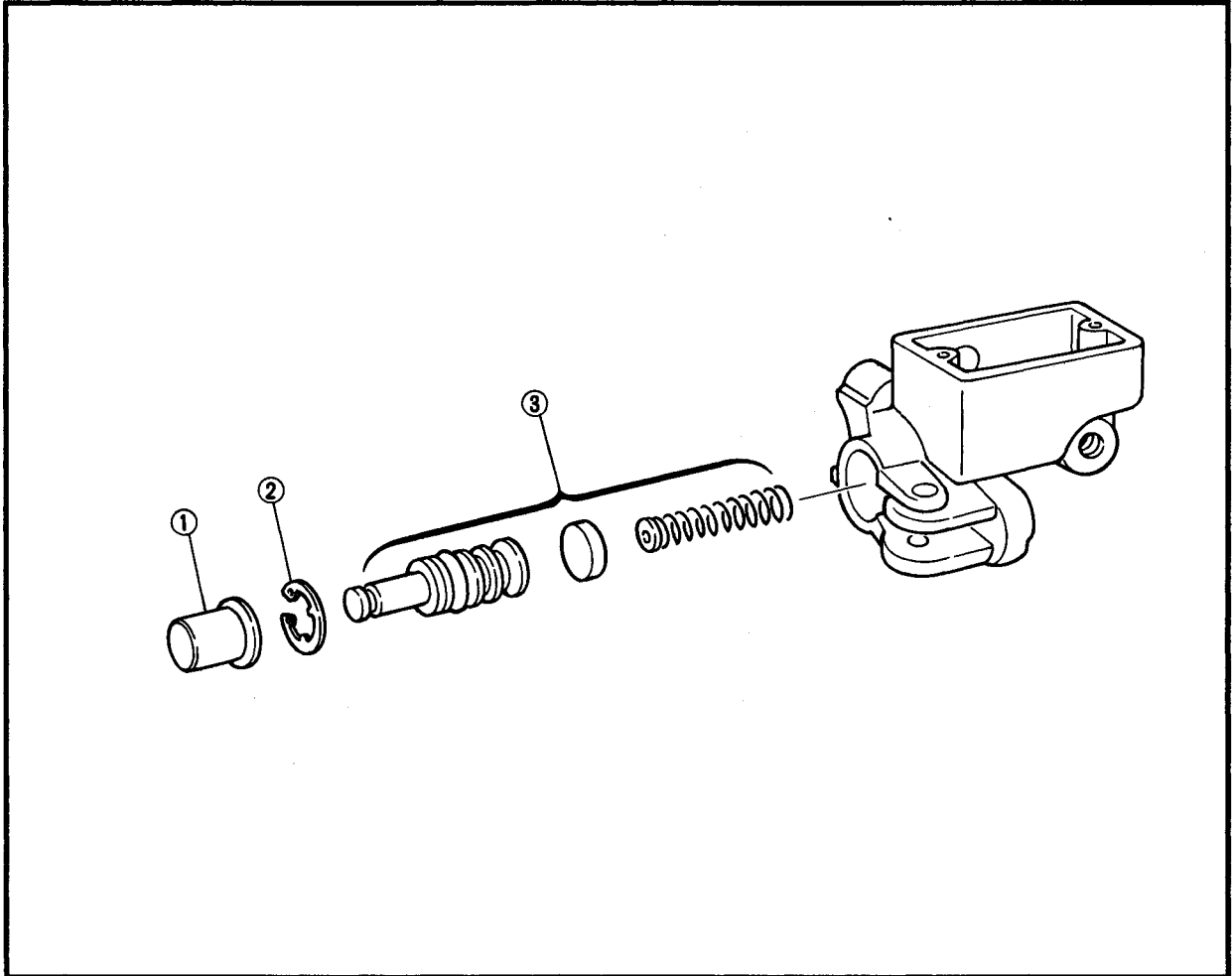

Order	Job name/Part name	Q'ty	Remarks
	Master cylinder disassembly		Disassemble the parts in the order below.
①	Dust boot	1	Refer to "MASTER CYLINDER ASSEMBLY".
②	Circlip	1	
③	Master cylinder cup kit	1	
			For assembly, reverse the disassembly procedure.

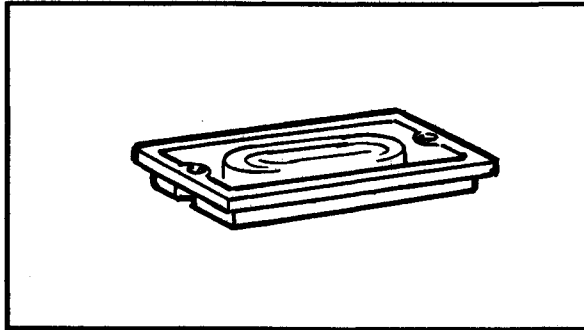
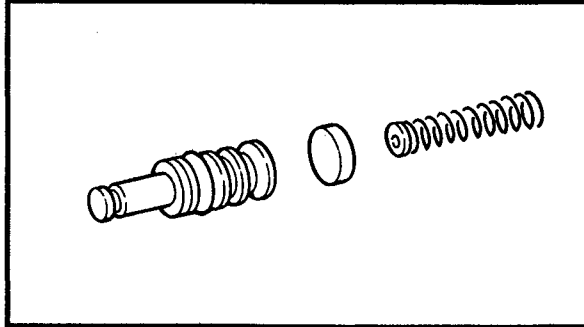
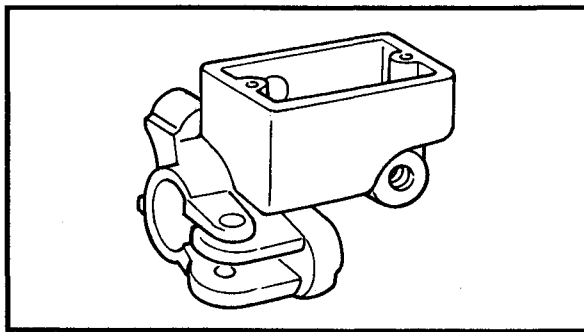

MASTER CYLINDER INSPECTION

1. Inspect:

- Master cylinder
Wear/scratches → Replace the master cylinder assembly.
- Master cylinder body
Cracks/damage → Replace.
- Oil delivery passage (master cylinder body)
Blockage → Blow out with compressed air.

2. Inspect:

- Master cylinder cup kit
Scratches/wear/damage → Replace as a set.

3. Inspect:

- Diaphragm
Wear/damage → Replace.

4. Inspect:

- Brake hose
Cracks/wear/damage → Replace.

EB702060

MASTER CYLINDER ASSEMBLY

⚠ WARNING

- All internal brake components should be cleaned and lubricated with new brake fluid only before installation.

	Recommended brake fluid: DOT 4
---	---

- Whenever a master cylinder is disassembled replace the piston seals and dust seals.

1. Install:

- Master cylinder cup kit
- Circlip **New**
- Dust boot

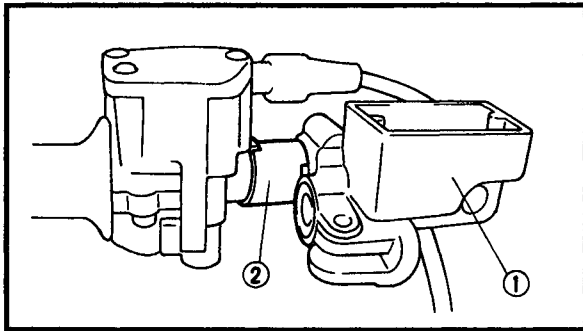
**MASTER CYLINDER INSTALLATION**

1.Install:

- Master cylinder ①

7 Nm (0.7 m · kg, 5.1 ft · lb)

NOTE:

- Engage the receptacle on the collar ② with the lobe on the throttle lever assembly.
- The "UP" mark on the master cylinder bracket should face up.

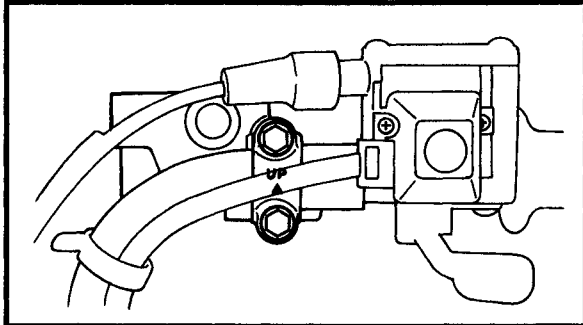

2.Install:

- Copper washers **New**

- Brake hose

- Union bolt

27 Nm (2.7 m · kg, 19 ft · lb)

NOTE:

- Tighten the union bolt while holding the brake hose as shown.
- Turn the handlebar to the left and to the right to check that the brake hose does not touch other parts (throttle cable, wire harness, leads, etc.). Correct if necessary.

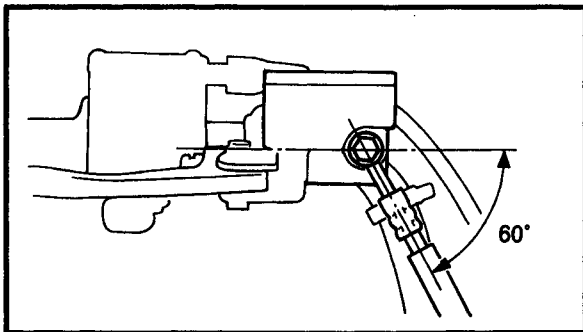
**⚠ WARNING**

Proper brake hose routing is essential to insure safe machine operation. Refer to "CABLE ROUTING".

3.Fill:

- Reservoir tank



Recommended brake fluid: DOT 4

CAUTION

Brake fluid may damage painted surfaces or plastic parts. Always clean up spilled brake fluid immediately.

**⚠ WARNING**

- Use only the designated quality brake fluid: other brake fluids may deteriorate the rubber seals, causing leakage and poor brake performance.
- Refill with the same type of brake fluid: mixing brake fluids may result in a harmful chemical reaction and lead to poor brake performance.
- Be careful that water does not enter the master cylinder when refilling. Water will significantly lower the boiling point of the brake fluid and may result in vapor lock.

4. Air bleed:

- Brake system
Refer to "AIR BLEEDING (HYDRAULIC BRAKE SYSTEM)" in CHAPTER 3.

5. Inspect:

- Brake fluid level
Brake fluid level is under the "LOWER" level line → Fill up.
Refer to "BRAKE FLUID LEVEL INSPECTION" in CHAPTER 3.

BRAKE CALIPER

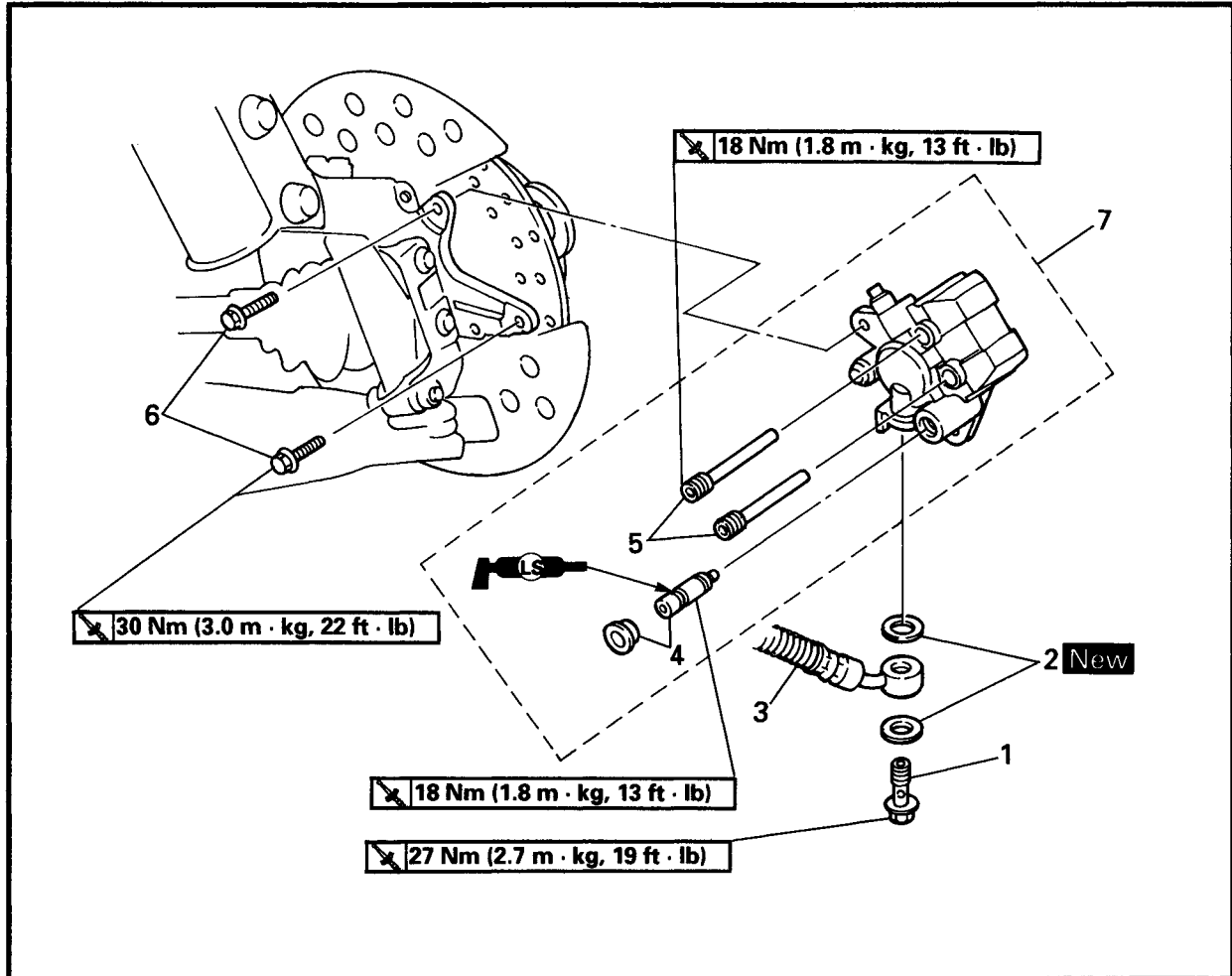

Order	Job name/Part name	Q'ty	Remarks
	Brake caliper removal		Remove the parts in the order below.
	Brake fluid		Drain
	Front wheel		Refer to "FRONT AND REAR WHEELS".
1	Union bolt	1] Refer to "CALIPER INSTALLATION".
2	Copper washer	2	
3	Brake hose	1	
4	Cap/retaining bolt	1/1	
5	Brake pad holding bolt	2	
6	Brake caliper mounting bolt	2	
7	Brake caliper assembly	1	
			For installation, reverse the removal procedure.

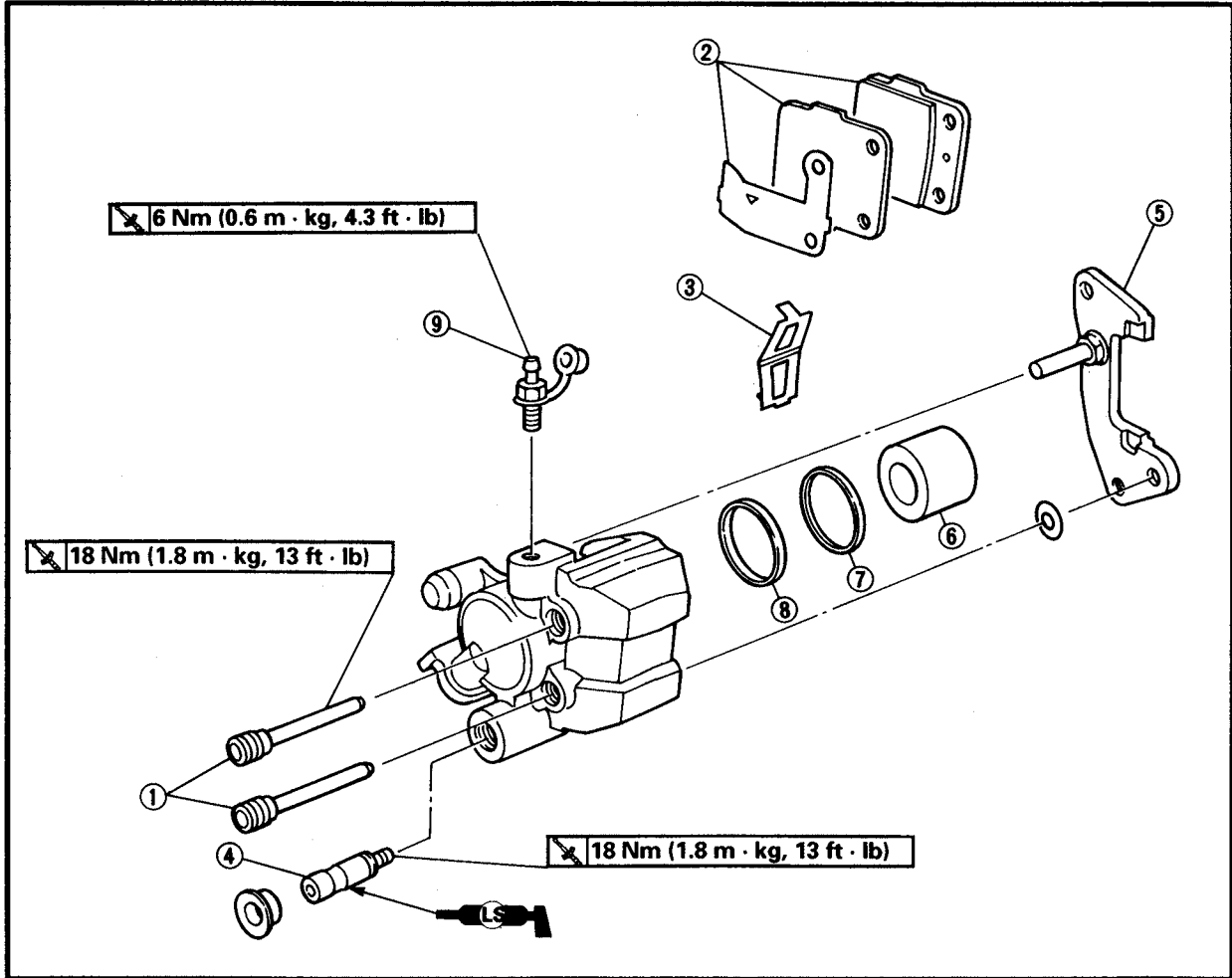

Order	Job name/Part name	Q'ty	Remarks
	Brake caliper disassembly		Disassemble the parts in the order below.
①	Brake pad holding bolt	2	Refer to "CALIPER DISASSEMBLY / ASSEMBLY". For assembly, reverse the disassembly procedure.
②	Brake pad/pad shim	2/1	
③	Pad spring	1	
④	Retaining bolt	1	
⑤	Caliper bracket	1	
⑥	Brake caliper piston	1	
⑦	Dust seal	1	
⑧	Caliper piston seal	1	
⑨	Bleed screw	1	

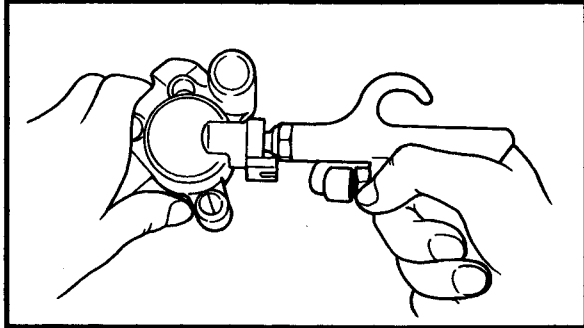
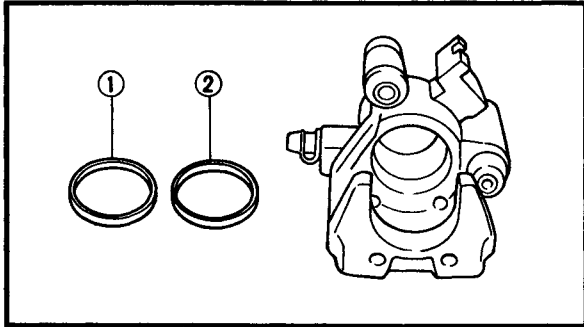

CALIPER DISASSEMBLY

1.Remove:

- Brake caliper piston
- Dust seal ①
- Caliper piston seal ②

Removal steps:

- Blow compressed air into the hose joint opening to force out the caliper piston from the brake caliper body.

⚠ WARNING

- Never try to pry out the caliper piston.
- Cover the caliper piston with a rag. Be careful not to get injured when the piston is expelled from the master cylinder.

- Remove the caliper piston seals.

EB702040

CALIPER INSPECTION

Recommended brake component replacement schedule:	
Brake pads	As required
Piston seal, dust seal	Every two years
Brake hoses	Every two years
Brake fluid	Replace when brakes are disassembled.

⚠ WARNING

All internal brake components should be cleaned in new brake fluid only. Do not use solvents as they will cause seals to swell and distort.

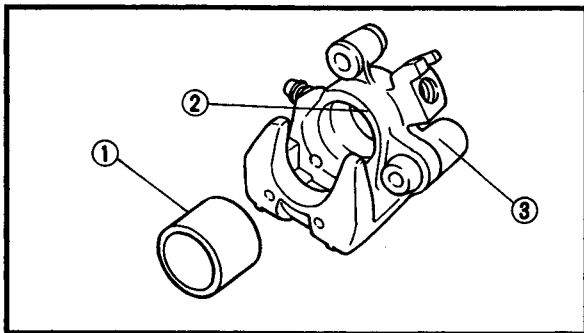

1.Inspect:

- Brake caliper piston ①
Scratches/rust/wear → Replace the brake caliper assembly.
- Brake caliper cylinder ②
Wear/scratches → Replace the brake caliper assembly.
- Brake caliper body ③
Cracks/damage → Replace.

- Oil delivery passage (brake caliper body)
Blockage → Blow out with compressed air.

⚠ WARNING

Replace the caliper piston seal and dust seal whenever the brake caliper is disassembled.

CALIPER ASSEMBLY

⚠ WARNING

- All internal brake components should be cleaned and lubricated with new brake fluid only before installation.

	Recommended brake fluid: DOT 4
---	---

- Replace the caliper piston seal whenever a brake caliper is disassembled.

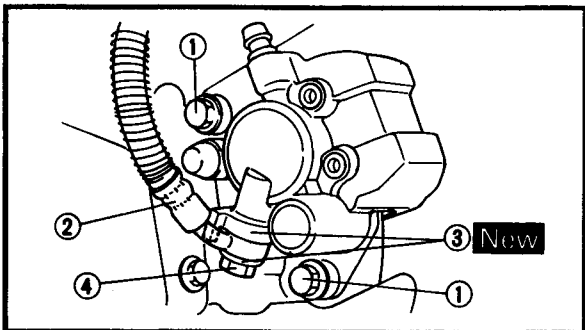
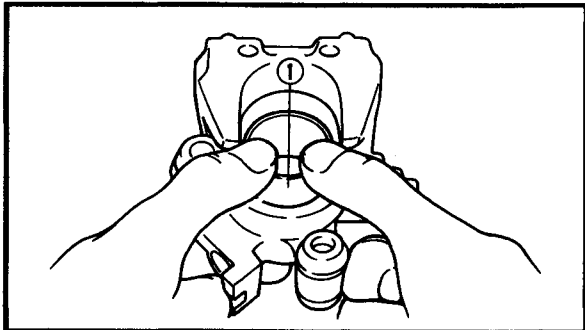
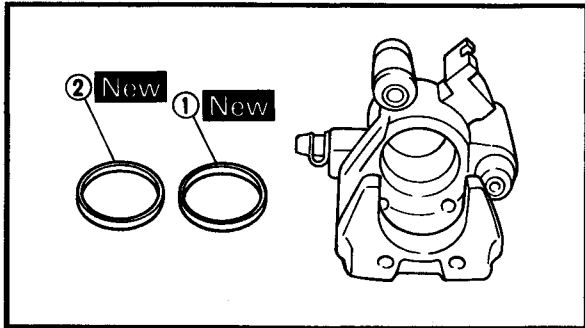

1.Install:

- Caliper piston seal ① **New**
- Dust seal ② **New**

2.Install:

- Brake caliper piston ①

CALIPER INSTALLATION

1.Install:

- Brake caliper assembly
- Brake caliper mounting bracket ① **30 Nm (3.0 m · kg, 22 ft · lb)**
- Brake hose ②
- Copper washers ③ **New**
- Union bolt ④ **27 Nm (2.7 m · kg, 19 ft · lb)**

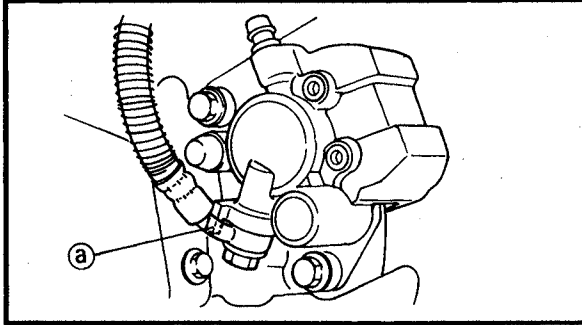
**CAUTION:**

When installing the brake hose on the brake caliper, make sure that the brake pipe touches the projection (a) on the brake caliper.

⚠ WARNING

Proper brake hose routing is essential to insure safe motorcycle operation. Refer to "CABLE ROUTING".

2.Fill:

- Brake reservoir



Recommended brake fluid:
DOT 4

CAUTION:

Brake fluid may damage painted surfaces or plastic parts. Always clean up spilled brake fluid immediately.

⚠ WARNING

- Use only the designated quality brake fluid: other brake fluids may deteriorate the rubber seals, causing leakage and poor brake performance.
- Refill with the same type of brake fluid: mixing brake fluids may result in a harmful chemical reaction and lead to poor brake performance.
- Be careful that water does not enter the master cylinder when refilling. Water will significantly lower the boiling point of the brake fluid and may result in vapor lock.

3.Air bleed

- Brake system
Refer to "AIR BLEEDING" in CHAPTER 3.

4.Inspect:

- Brake fluid level
Brake fluid level is under the "LOWER" level line → Fill up.
Refer to "BRAKE FLUID INSPECTION" in CHAPTER 3.

REAR BRAKE

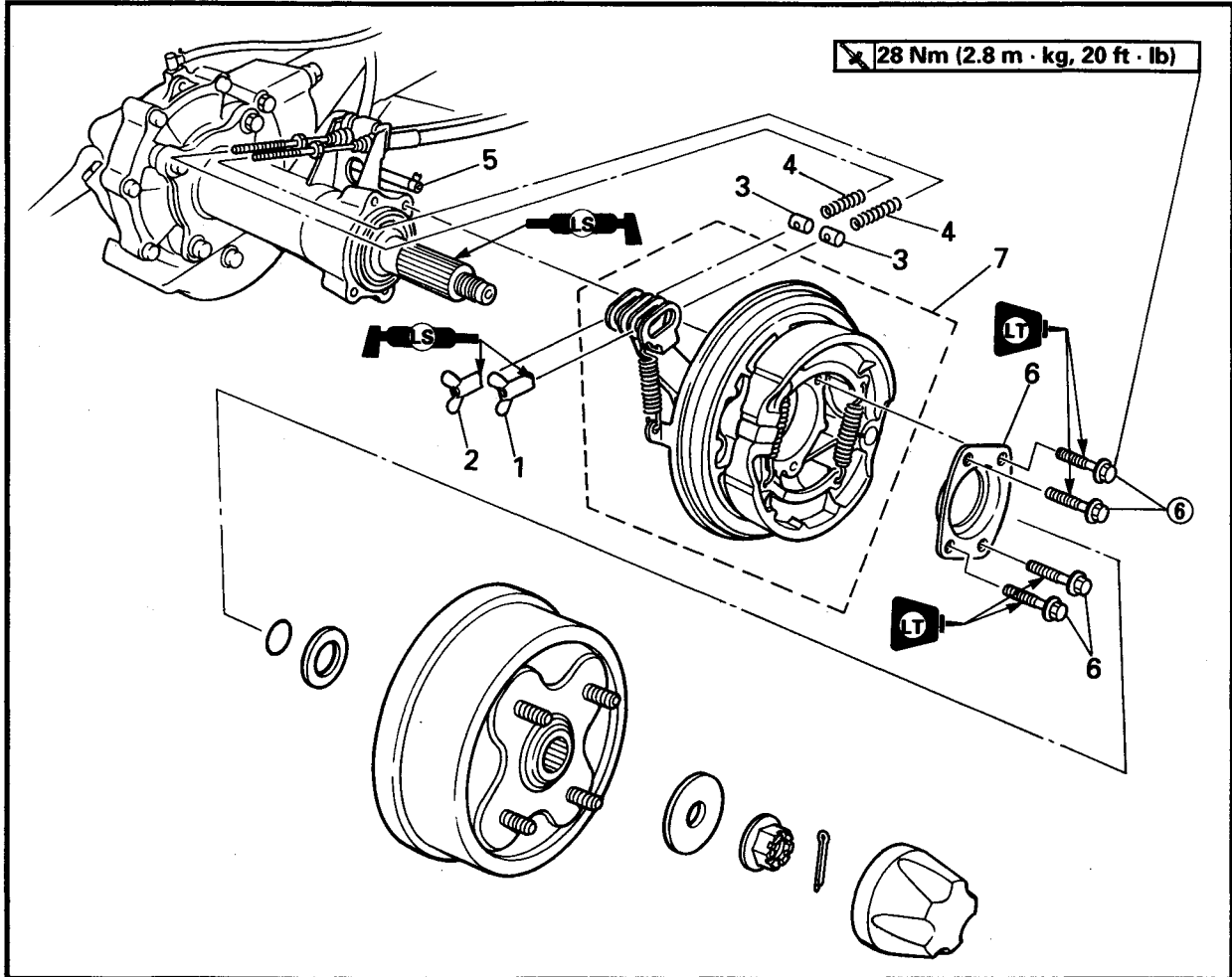

Order	Job name/Part name	Q'ty	Remarks
	Rear brake removal		Remove the parts in the order below.
	Right rear wheel		Refer to "FRONT AND REAR WHEELS".
	Brake drum		
1	Brake pedal adjuster	1	
2	Brake lever adjuster	1	
3	Pin	2	
4	Spring	2	
5	Rear brake breather hose	1	Disconnect
6	Bolt/bearing retainer	4/1	Refer to "REAR BRAKE INSTALLATION".
7	Brake shoe assembly	1	For installation, reverse the removal procedure.

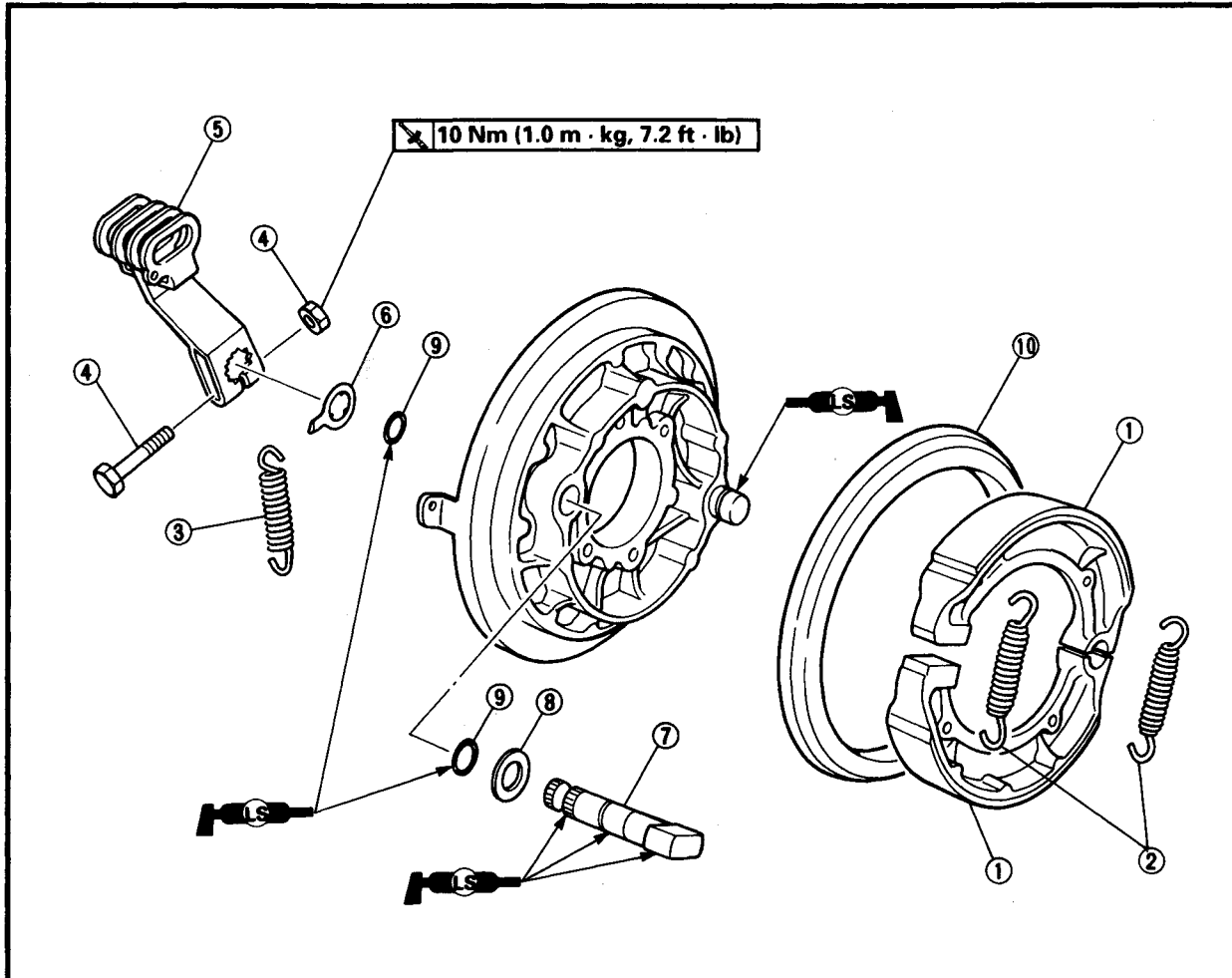

Order	Job name/Part name	Q'ty	Remarks
	Rear brake disassembly		Disassemble the parts in the order below.
①	Brake shoe	2	Refer to "REAR BRAKE ASSEMBLY". For assembly, reverse the disassembly procedure.
②	Tension spring	2	
③	Spring	1	
④	Bolt/nut	1/1	
⑤	Brake camshaft lever	1	
⑥	Wear indicator plate	1	
⑦	Brake camshaft	1	
⑧	Washer	1	
⑨	O-ring	2	
⑩	Dust seal	1	

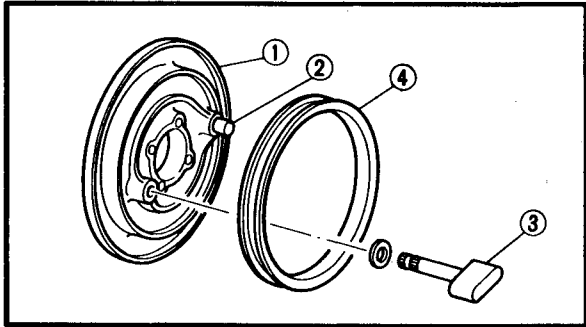

BRAKE SHOE PLATE INSPECTION

1. Inspect:

- Brake shoe plate ①
- Pivot pin ②
- Brake camshaft ③
Bends/cracks/damage → Replace.
- Dust seal ④
Wear/damage → Replace.

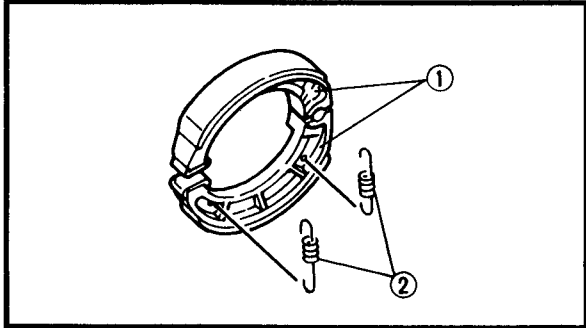

BRAKE SHOE INSPECTION

1. Inspect:

- Brake shoes ①
- Brake shoe springs ②
Cracks/damage → Replace as a set.

NOTE:

When replacing the brake shoes, replace the brake shoe springs at the same time.

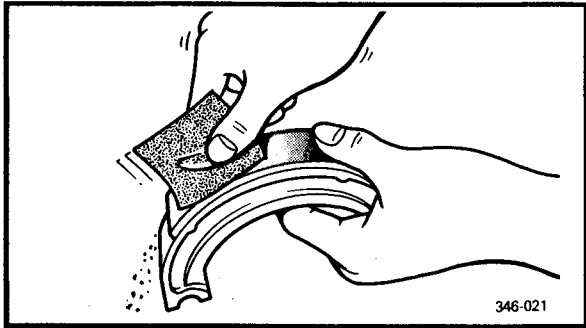

2. Inspect:

- Brake shoe lining surface
Glazed areas → Remove.
Use coarse sandpaper.

NOTE:

After using the sandpaper, wipe off the polished particles with a cloth.

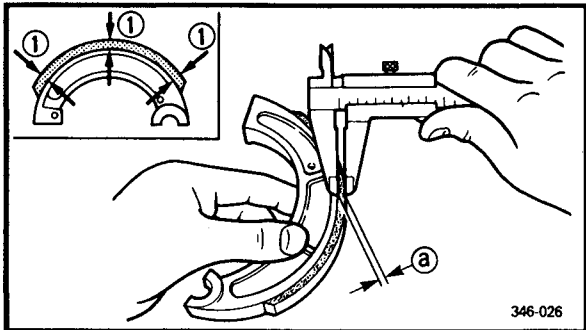

3. Measure:

- Brake shoe lining thickness ②
Out of specification → Replace.
- ① Measuring points

NOTE:

Replace the brake shoes as a set if either is found to be worn to the wear limit.



Brake lining thickness:

4.0 mm (0.16 in)

<Wear limit>:

1.0 mm (0.04 in)

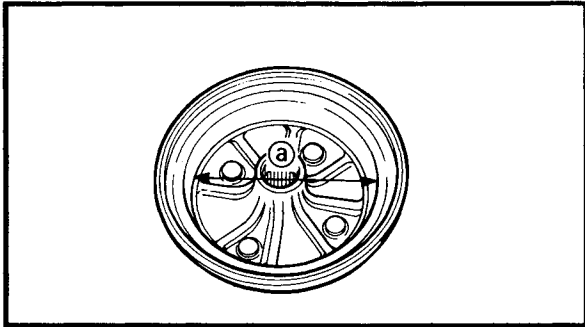

BRAKE DRUM INSPECTION

1.Measure:

- Brake drum inside diameter ^a
Out of specification → Replace.



Front brake drum inside diameter:
160 mm (6.30 in)
<Wear limit>:
161 mm (6.34 in)

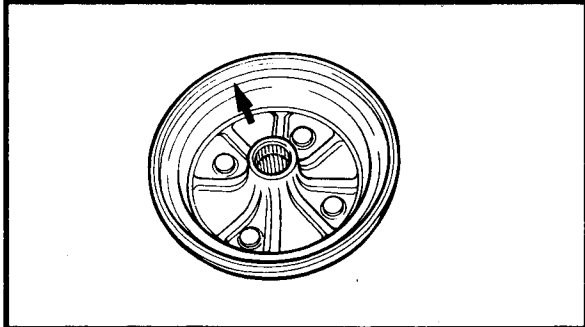

2.Inspect:

- Brake drum inner surface
Oil/scratches → Remove.

Oil	Use a rag soaked in lacquer thinner or solvent.
Scratches	Use an emery cloth (lightly and evenly polishing).

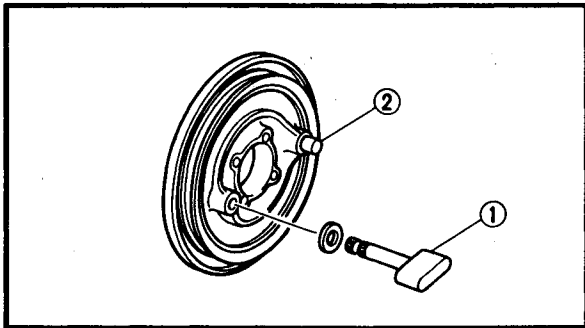

REAR BRAKE ASSEMBLY

Reverse the "Removal" procedure.

Note the following points.

1.Lubricate:

- Brake camshaft ①
- Pivot pin ②



Lithium-soap base grease

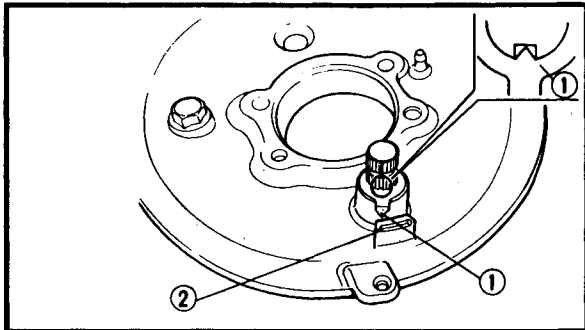

CAUTION:

During installation, lightly grease the brake camshaft and the pivot pin. Wipe off the excess grease.

2.Install:

- Wear indicator plate ①

NOTE:

When installing the wear indicator plate, fit the projection into a brake camshaft groove and align the wear indicator plate with the left end of the wear indicator scale ②.

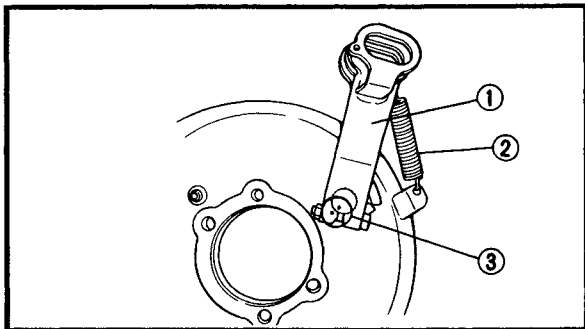

3.Install:

- Brake camshaft lever ①

 10 Nm (1.0 m · kg, 7.2 ft · lb)

- Spring ②

NOTE:

When installing the brake camshaft lever, align the punch mark ③ on the brake camshaft lever and brake camshaft.

4.Install:

- Tention springs
- Brake shoes

5.Check:

- Brake camshaft operation
Unsmooth operation → Repair.

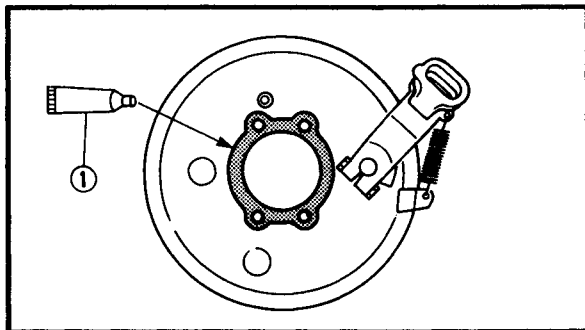

REAR BRAKE INSTALLATION

1.Apply:

- Sealant ①
(onto the mating surfaces of swingarm)



Sealant (Quick Gasket)®:
P/N. ACC-11001-05-01
Yamaha bond No. 1215®:
P/N. 90890-85505

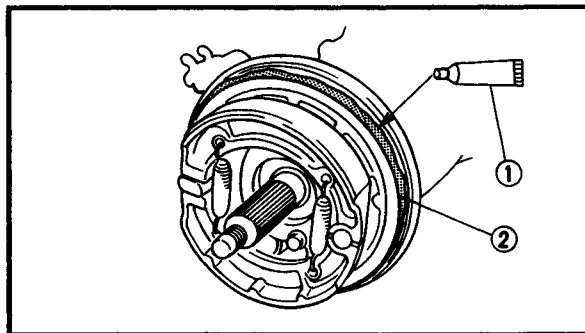

2.Install:

- Rear brake assembly
- Bearing retainer

 28 Nm (2.8 m · kg, 20 ft · lb)

3.Apply:

- Yamaha brake grease ①
(to the dust seal ② and to the area of the brake drum contacting the dust seal)



Yamaha brake grease:
P/N. 90793-40003

STEERING SYSTEM
HANDLEBAR

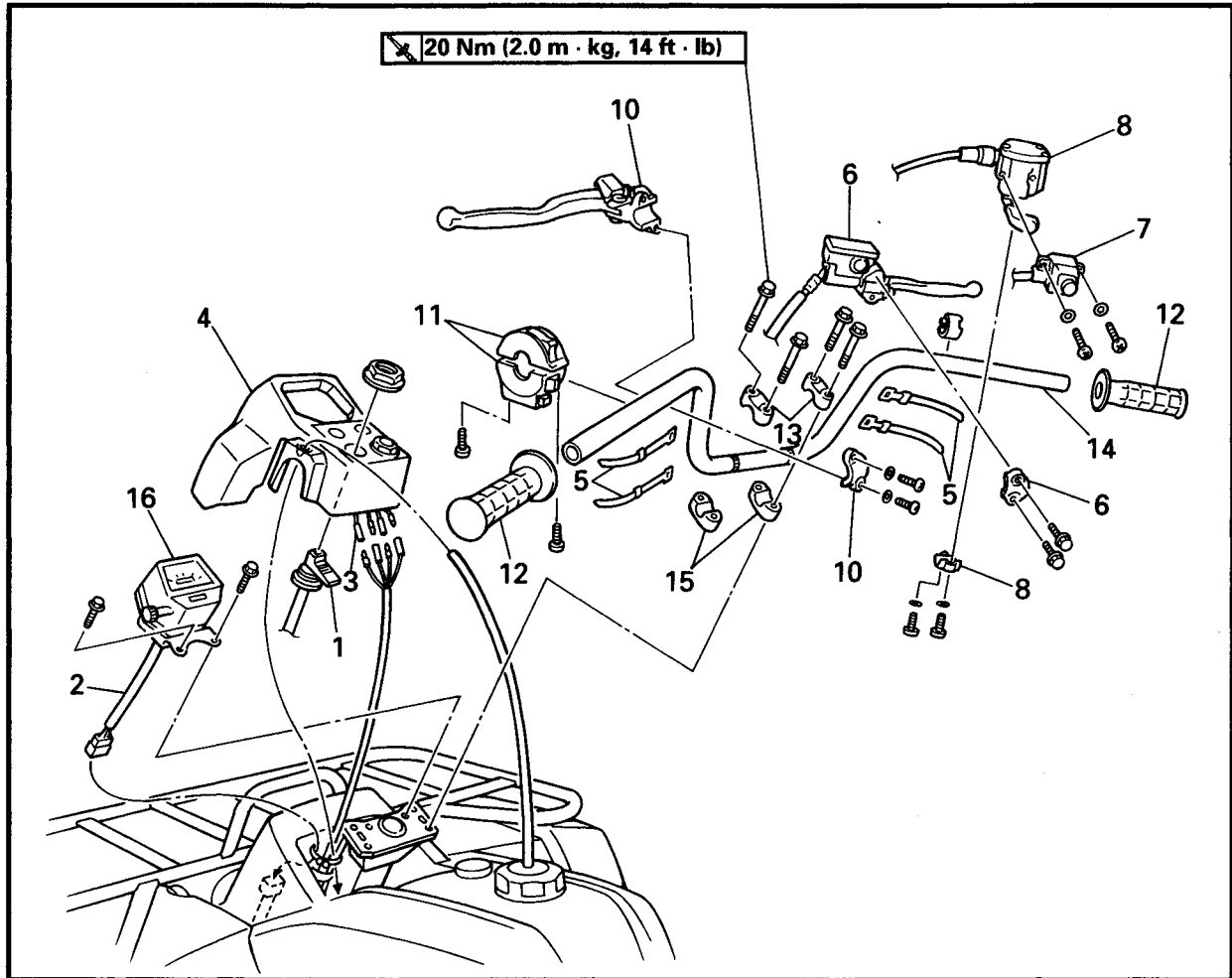

Order	Job name/Part name	Q'ty	Remarks
	Handlebar removal		Remove the parts in the order below.
1	Starter knob	1	Disconnect } Refer to "CABLE ROUTING" in CHAPTER 2.
2	Main switch lead	1	
3	Indicator light lead	4	
4	Handlebar cover	1	
5	Band	4	
6	Master cylinder assembly / bracket	1/1	Refer to "MASTER CYLINDER ASSEMBLY INSTALLATION".
7	4WD / 2WD select switch	1	
8	Throttle lever assembly / bracket	1/1	
9	Collar	1	
10	Rear brake lever / bracket	1/1	Refer to "REAR BRAKE LEVER INSTALLATION".
11	Handlebar switch	1	
12	Handlebar grip	2	
13	Handlebar holder (upper)	2	Refer to "HANDLEBAR INSTALLATION".

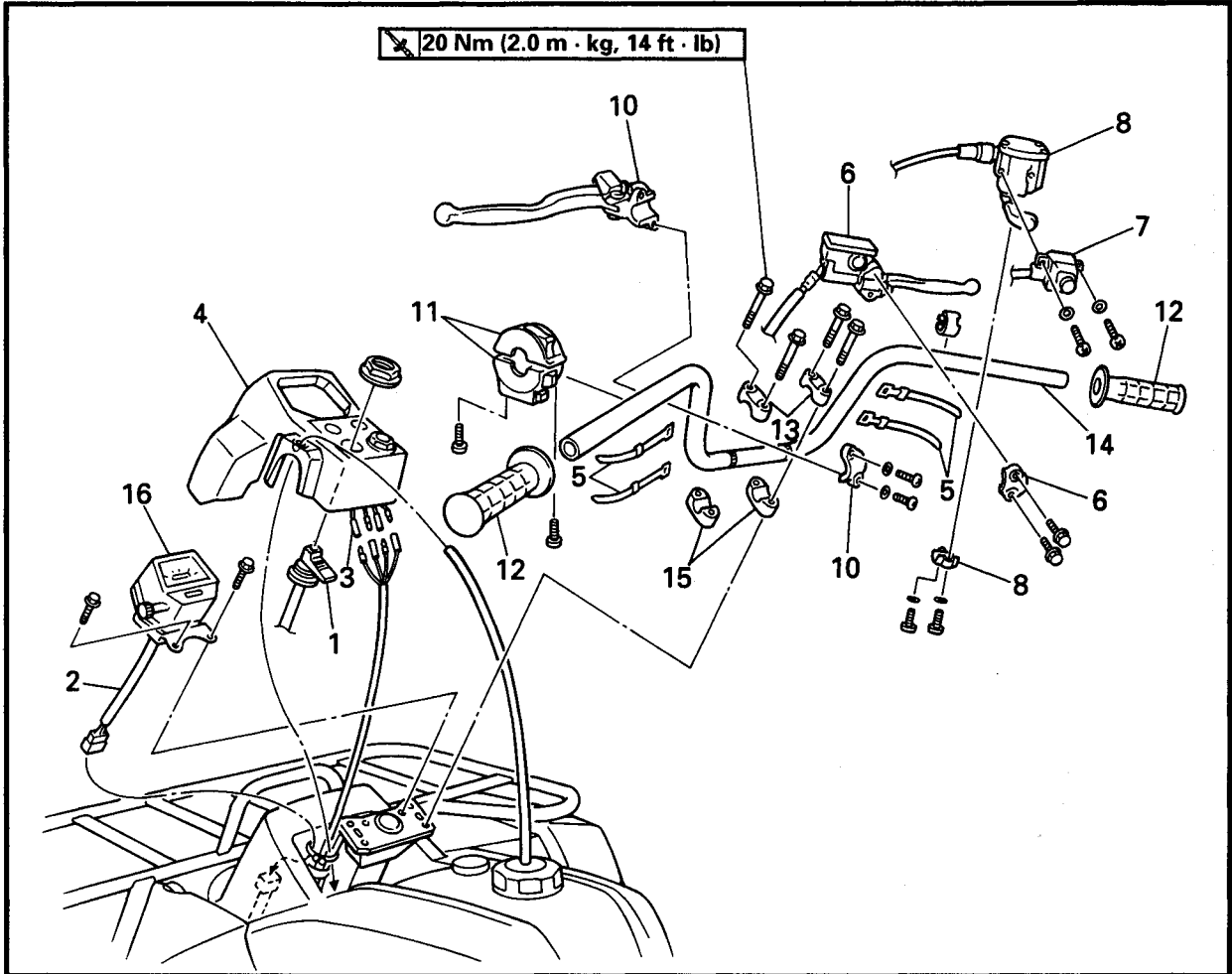

Order	Job name/Part name	Q'ty	Remarks
14	Handlebar	1	Refer to "HANDLEBAR INSTALLATION". For installation, reverse the removal procedure.
15	Handlebar holder (lower)	2	
16	Speedometer	1	

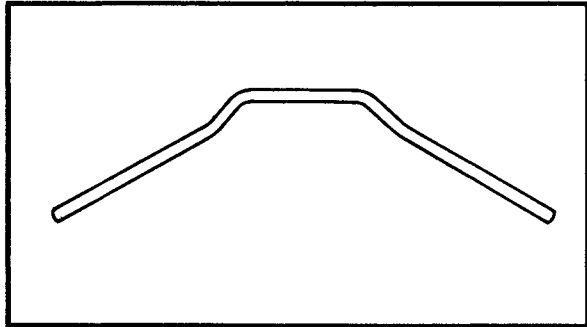

HANDLEBAR INSPECTION

1. Inspect:
- Handlebar
 - Bends/cracks/damage → Replace.

⚠ WARNING

Do not attempt to straighten a bent handlebar as this may dangerously weaken the handlebar.

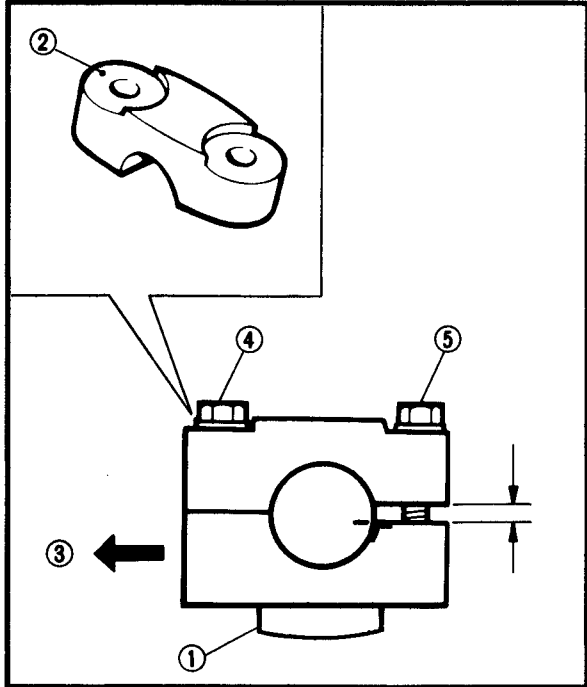

HANDLEBAR INSTALLATION

1. Install:
- Handlebar
 - Handlebar holders (upper and lower)

⚡ 20 Nm (2.0 m · kg, 14 ft · lb)

NOTE:

- Insert the projection ① of the handlebar holder (lower) into the steering shaft hole.
- The upper handlebar holder should be installed with the punched mark ② forward ③.

CAUTION:

First tighten the bolts ④ on the front side of the handlebar holder, and then tighten the bolts ⑤ on the rear side.

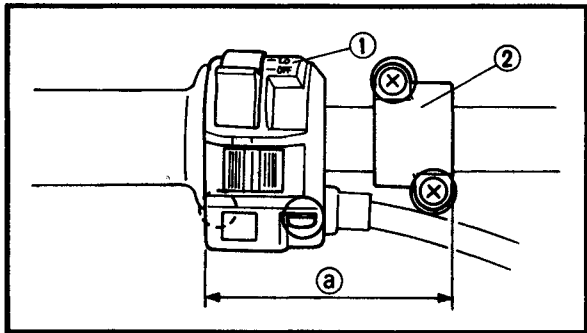

REAR BRAKE LEVER INSTALLATION

1. Install:
- Handlebar switch ①
 - Rear brake lever
 - Lever bracket ②

NOTE:

Install the lever bracket as shown.

② 80 mm (3.1 in)

MASTER CYLINDER ASSEMBLY INSTALLATION

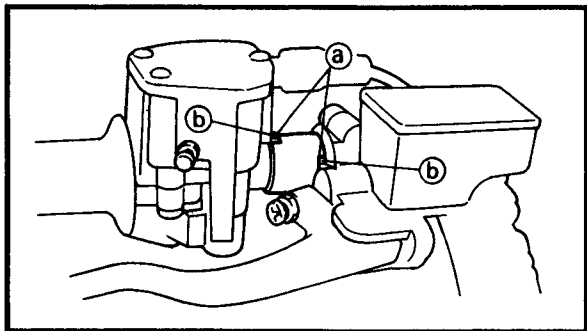

1. Install:

- Throttle lever assembly
- Collar
- Master cylinder assembly

⚡ 7 Nm (0.7 m · kg, 5.1 ft · lb)

NOTE:

- Engage the indentations ① in the collar with the lobes ② on the throttle lever assembly and master cylinder.
- The "UP" mark on the master cylinder bracket should face up.

STEERING STEM

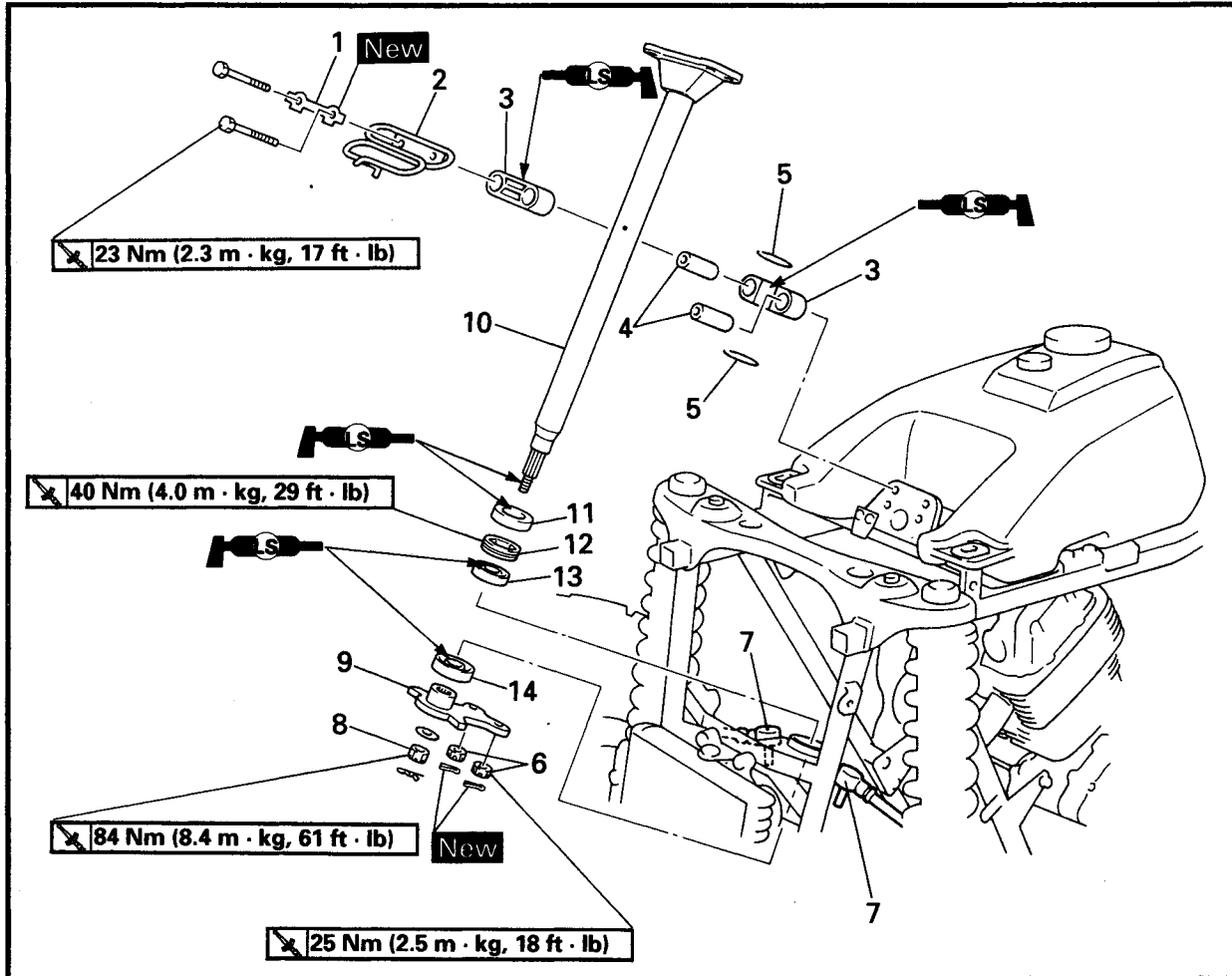

Order	Job name/Part name	Q'ty	Remarks
	Steering removal		Remove the parts in the order below.
	Handlebar		Refer to "HANDLEBAR".
	Seat		Refer to "SEAT, CARRIERS, FENDERS AND FUEL TANK" in CHAPTER 3.
	Front fender		
1	Lock washer	1	Refer to "CABLE GUIDE INSTALLATION".
2	Cable guide	1	
3	Steering stem busing	2	
4	Collar	2	
5	Oil seat	2	
6	Tie-rod end nut	2	
7	Tie-rod	2	Disconnect
8	Steering stem nut	1	
9	Pitman arm	1	
10	Steering stem	1	

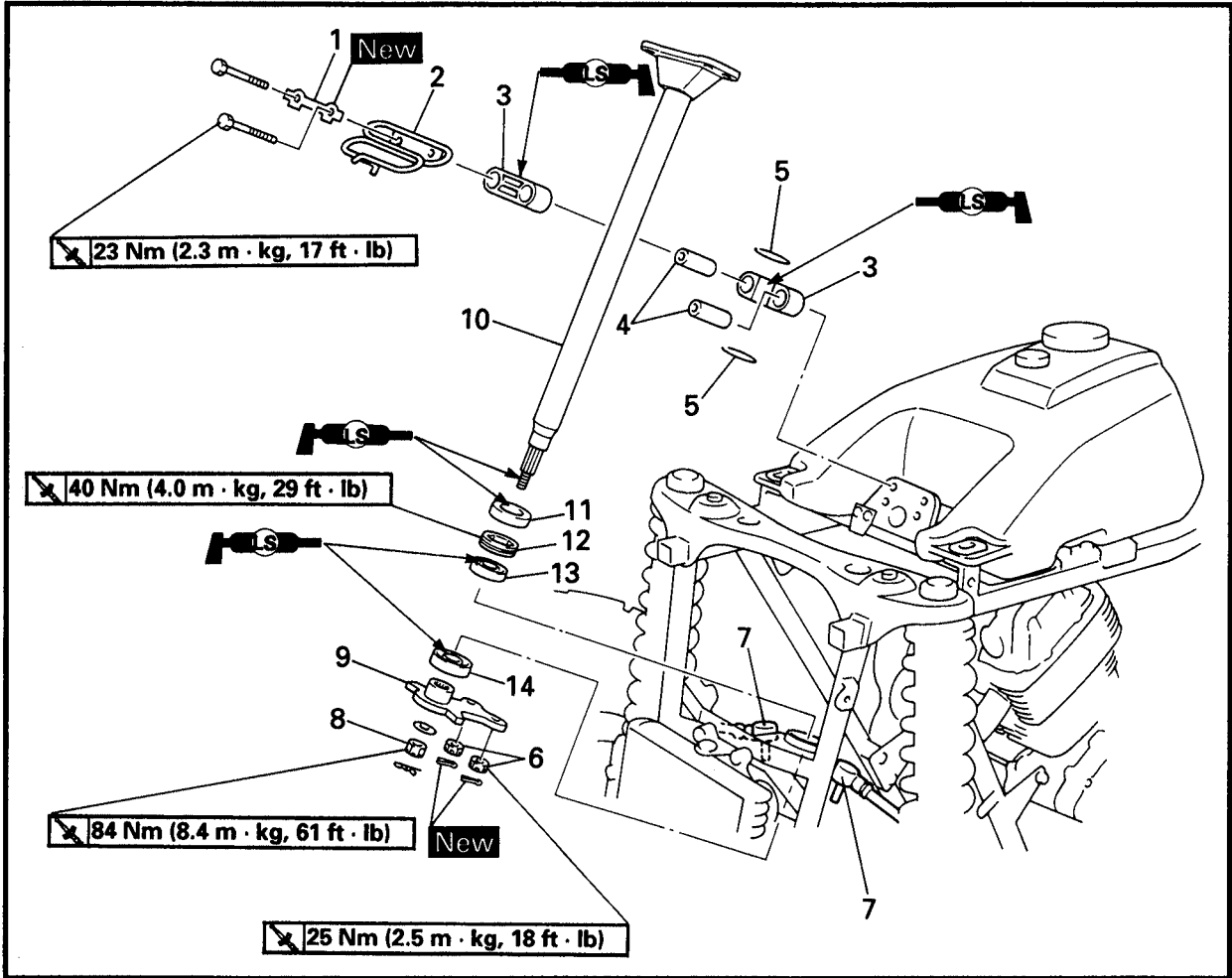

Order	Job name/Part name	Q'ty	Remarks
11	Oil seal	1	Refer to "BEARING RETAINER REMOVAL/INSTALLATION".
12	Bearing retainer	1	
13	Bearing	1	
14	Oil seal	1	For installation, reverse the removal procedure.

BEARING RETAINER REMOVAL

1. Remove:
 - Bearing retainer (steering stem)

	<p>Damper rod holder: P/N. 90890-01375</p>
---	---

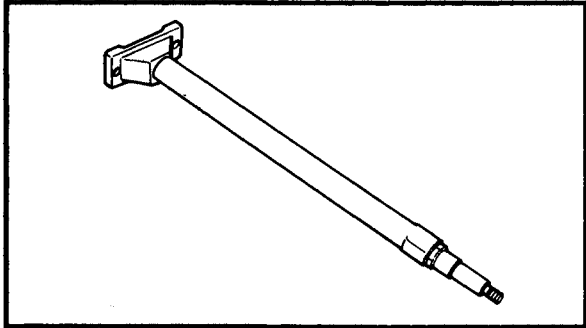

STEERING STEM INSPECTION

1. Inspect:
 - Steering stem
 - Bends → Replace.

⚠ WARNING

Do not attempt to straighten a bent stem; this may dangerously weaken the stem.

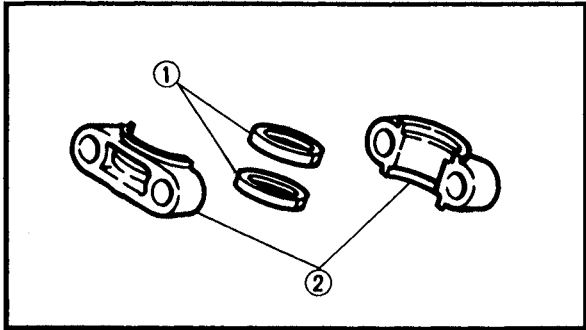

2. Inspect:
 - Oil seals ①
 - Steering stem bushings ②
 - Wear/damage → Replace.

BEARING, RETAINER INSTALLATION

1. Install:
 - Bearing retainer (steering stem)

 **40 Nm (4.0 m · kg, 29 ft · lb)**

	<p>Damper rod holder: P/N. 90890-01375</p>
---	---

CABLE GUIDE INSTALLATION

1. Install
 - Cable guide
 - Lock washer **New**

 **23 Nm (2.3 m · kg, 17 ft · lb)**

2. Bend the lock washer tab along a flat side of the bolt.

NOTE: Pass the cables and hoses through the cable guide. Refer to "CABLE ROUTING" in CHAPTER 2.

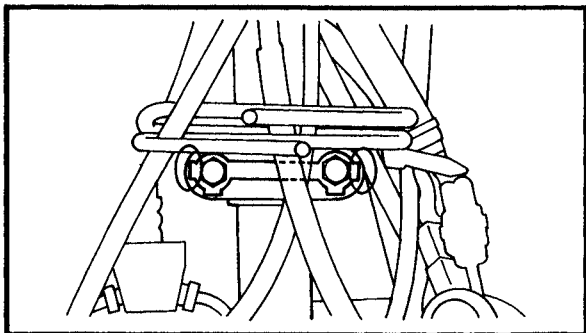

TIE-ROD AND STEERING KNUCKLE

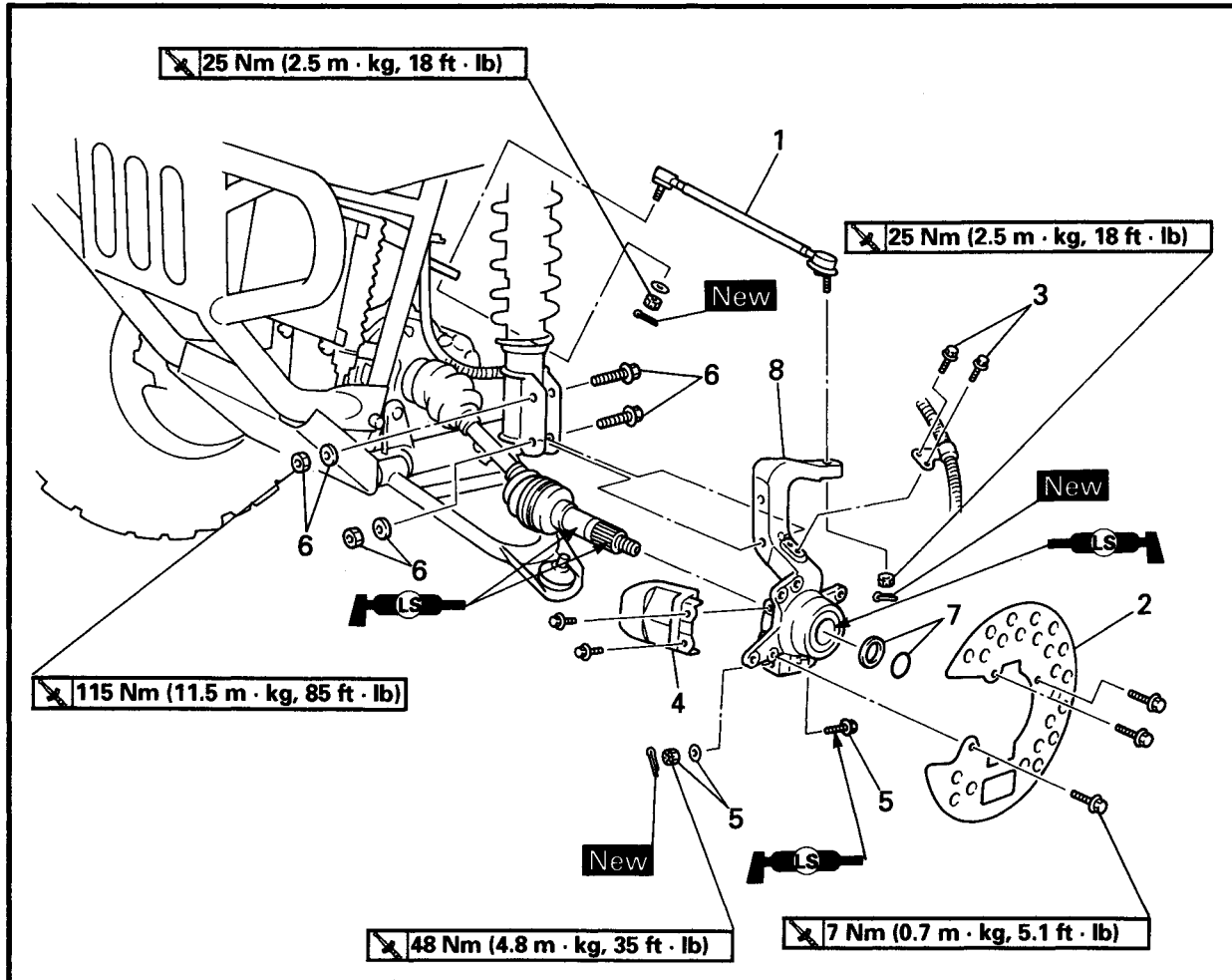

Order	Job name/Part name	Q'ty	Remarks
	Tie-rod and steering knuckle removal		Remove the parts in the order below.
	Front fender		Refer to "SEAT, CARRIERS, FENDERS AND FUEL TANK" in CHAPTER 3.
	Front wheel / brake disc		Refer to "FRONT AND REAR WHEELS".
1	Tie-rod	1	Refer to "TIE-ROD INSTALLATION".
2	Brake disc guard	1	
3	Brake hose holder bolt	2	
4	Constant velocity joint protector	1	
5	Bolt / washer / nut	1/1/1	
6	Bolt / washer / nut	2/2/2	
7	O-ring / washer	1/1	
8	Steering knuckle	1	Refer to "STEERING KNUCKLE REMOVAL".
			For installation, reverse the removal procedure.

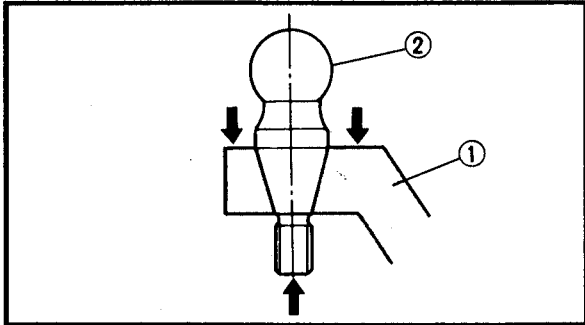

STEERING KNUCKLE REMOVAL

- 1.Remove:
- Steering knuckle ①

NOTE: _____
 Use a general puller to separate the ball joint ② and steering knuckle.

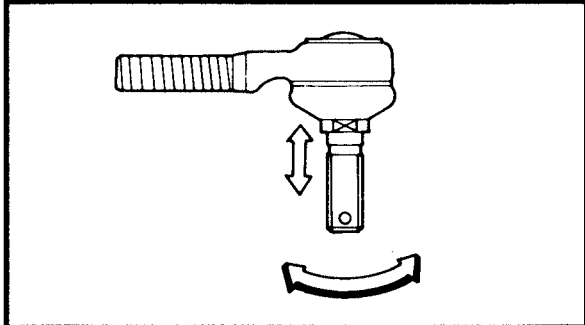

TIE-ROD INSPECTION

- 1.Check:
- Tie-rod free play and movement
 Free play → Replace the tie-rod end.
 Turns roughly → Replace the tie-rod end.
- 2.Inspect:
- Tie-rod
 - Bends/damage → Replace.

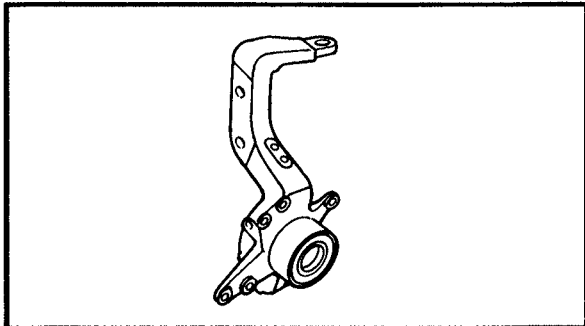

STEERING KNUCKLE INSPECTION

- 1.Inspect:
- Steering knuckle
 Damage/pitting → Replace.

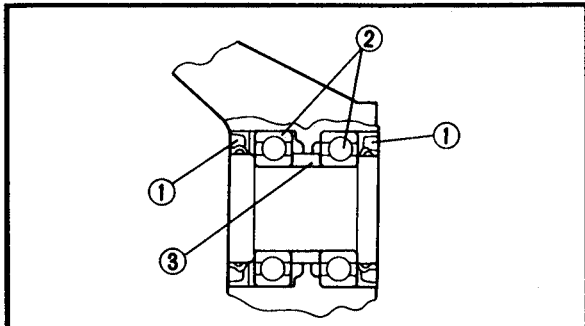

- 2.Inspect:
- Front wheel bearings
 Bearings allow play in the wheel hubs or the wheel turns roughly → Replace.
 - Oil seals
 Damage → Replace.

Front wheel bearing replacement steps:

- Clean the outside of the steering knuckle.
- Remove the oil seals ①.
- Drive out the bearings ②.

⚠ WARNING

Eye protection is recommended when using striking tools.

- Remove the spacer ③.
- Apply lithium base grease to the bearings and oil seals.
- Install the spacer to the steering knuckle.



- Install the new bearings.

NOTE: _____
Install the outside bearing first.

CAUTION: _____

Do not strike the center race or balls of the bearing. Contact should be made only with the outer race.

- Install a new oil seal.

NOTE: _____
When installing the oil seals the seal side of the oil seal faces out.

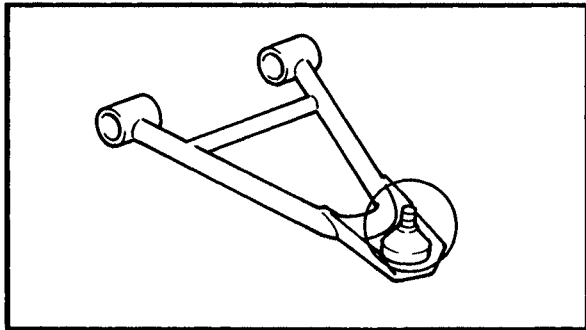

BALL JOINT INSPECTION

1. Inspect:
- Ball joint
Damage/pitting → Replace the front arm.
Free play → Replace the front arm.
Turns roughly → Replace the front arm.

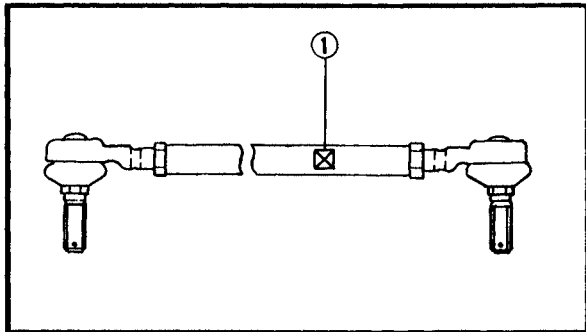

TIE-ROD INSTALLATION

1. Install:
- Tie-rods (left and right)

25 Nm (2.5 m · kg, 18 ft · lb)

NOTE: _____
The tie-rod which must be installed on the right side has a white painted mark ①.

2. Adjust:
- Toe-in
Refer to "TOE-IN ADJUSTMENT" in CHAPTER 3.

FRONT ARM AND FRONT SHOCK ABSORBER



FRONT ARM AND FRONT SHOCK ABSORBER

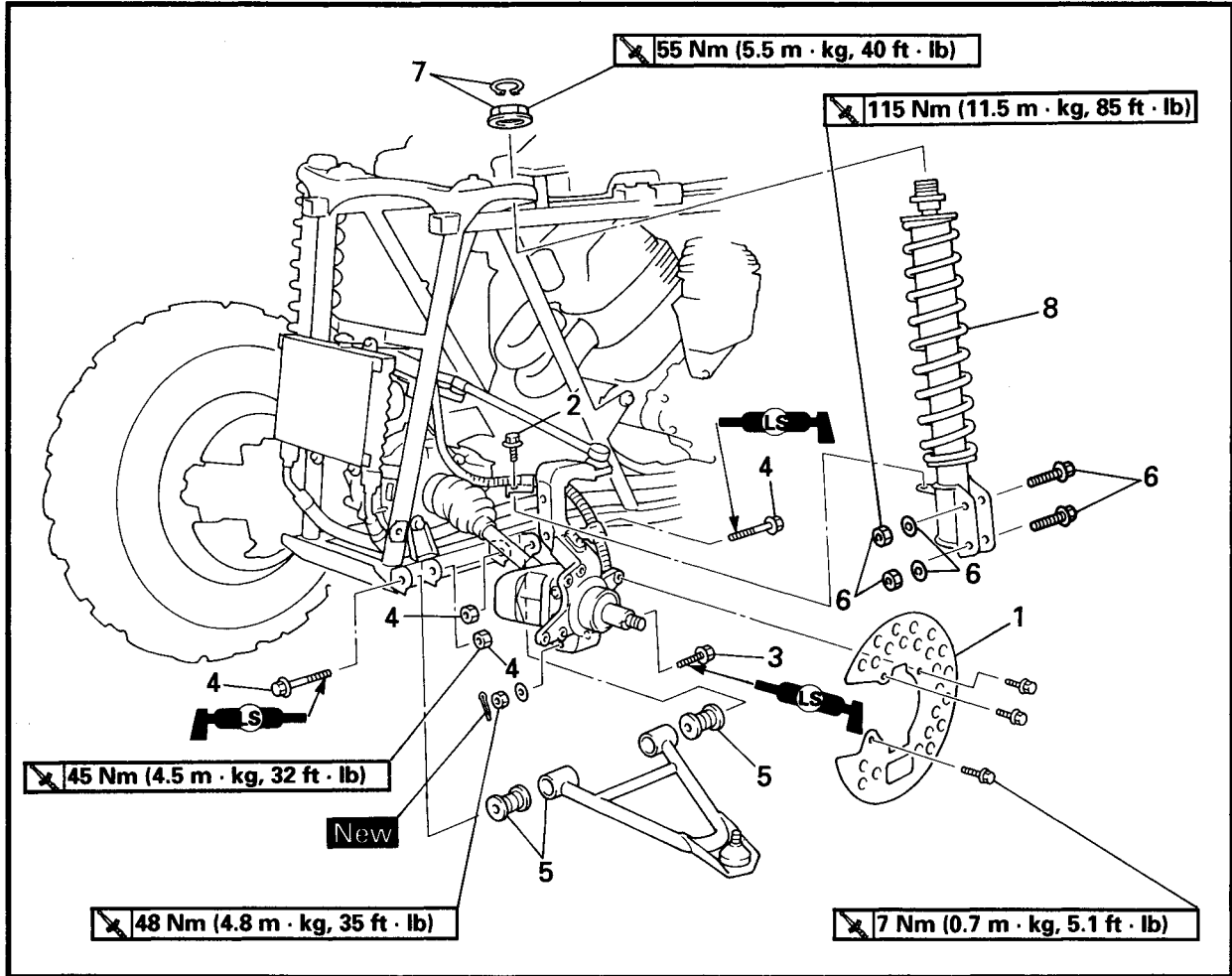

Order	Job name/Part name	Q'ty	Remarks
	Front arm and front shock absorber removal		Remove the parts in the order below.
	Differential gear skid plate		Refer to "SEAT, CARRIERS, FENDERS AND FUEL TANK" in CHAPTER 3.
	Front fender		
	Front wheel / brake disc		
1	Brake disc guard	1	
2	Brake hose holding bolt	1	
3	Bolt	1	
4	Bolt / nut	2/2	
5	Front arm / bushing	1/2	Refer to "FRONT ARM REMOVAL/ INSTALLATION".
6	Bolt / washer / nut	2/2/2	
7	Circlip / nut	1/1	
8	Front shock absorber	1	
			For installation, reverse the removal procedure.

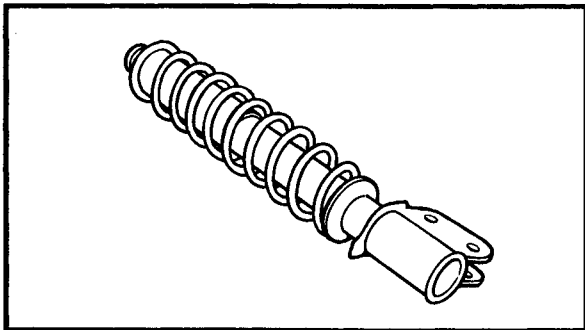
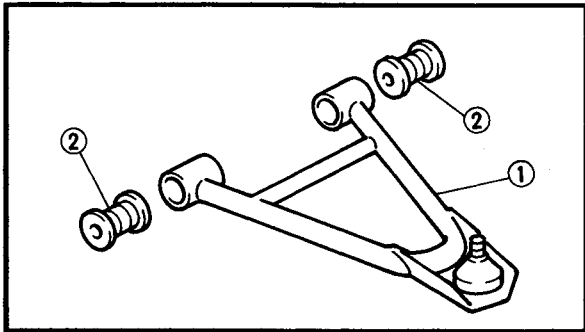
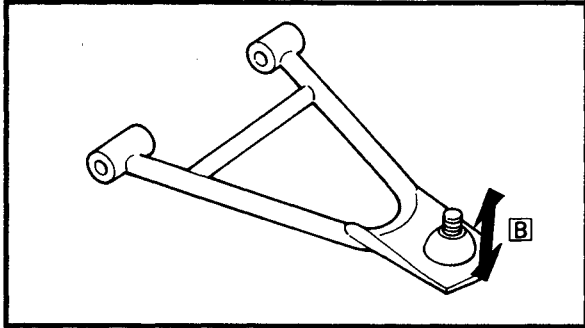
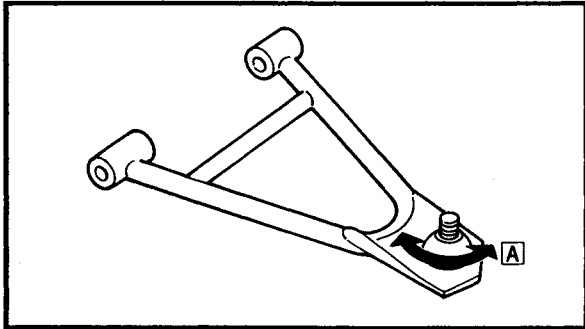

FRONT ARM REMOVAL

1. Check:

- Front arm free play

Checking steps:

- Check the front arm side play **A** by moving it from side to side.

If side play is noticeable, check the bushings.

- Check the front arm vertical movement **B** by moving it up and down.

If the vertical movement is tight, binding or rough, check the bushings.

2. Remove:

- FRONT ARM

FRONT ARM INSPECTION

1. Inspect:

- Front arm **1**
Bends/damage → Replace.

2. Inspect:

- Bushings **2**
Wear/damage → Replace.

FRONT SHOCK ABSORBER INSPECTION

1. Inspect:

- Shock absorber rod
Bends/damage → Replace the shock absorber assembly.

- Shock absorber assembly
Oil leaks → Replace the shock absorber assembly.

- Spring
Fatigue → Replace the shock absorber assembly.

Move the spring up and down.

FRONT ARM AND FRONT SHOCK ABSORBER

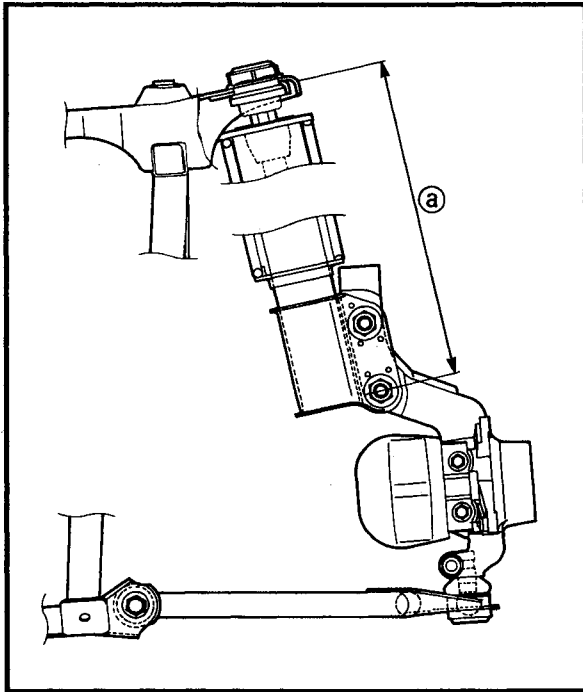
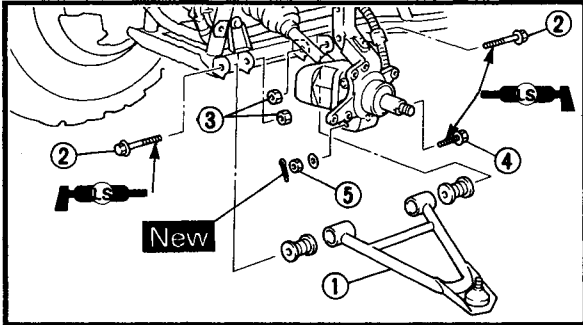

FRONT ARM INSTALLATION

1. Install:

- Front arm

Front arm installation steps:

- Install the front arm (1), bolts (2) and nuts (3).

NOTE:

- Lubricate the bolts (2) with lithium-soap base grease.
- Be sure to position the bolts so that the bolt head faces outward.
- Temporarily tighten the nuts.

- Install the ball joint.

- Install bolt (4), washer and nut (5).

	Nut (5): 48 Nm (4.8 m · kg, 35 ft · lb)
--	--

- Install the new cotter pin.

- Tighten the nuts (3).

NOTE:

Before tightening the nuts (3), adjust length (a) to 417 mm (16.4 in).

	Nut (3): 45 Nm (4.5 m · kg, 32 ft · lb)
--	--

REAR SHOCK ABSORBER AND SWINGARM

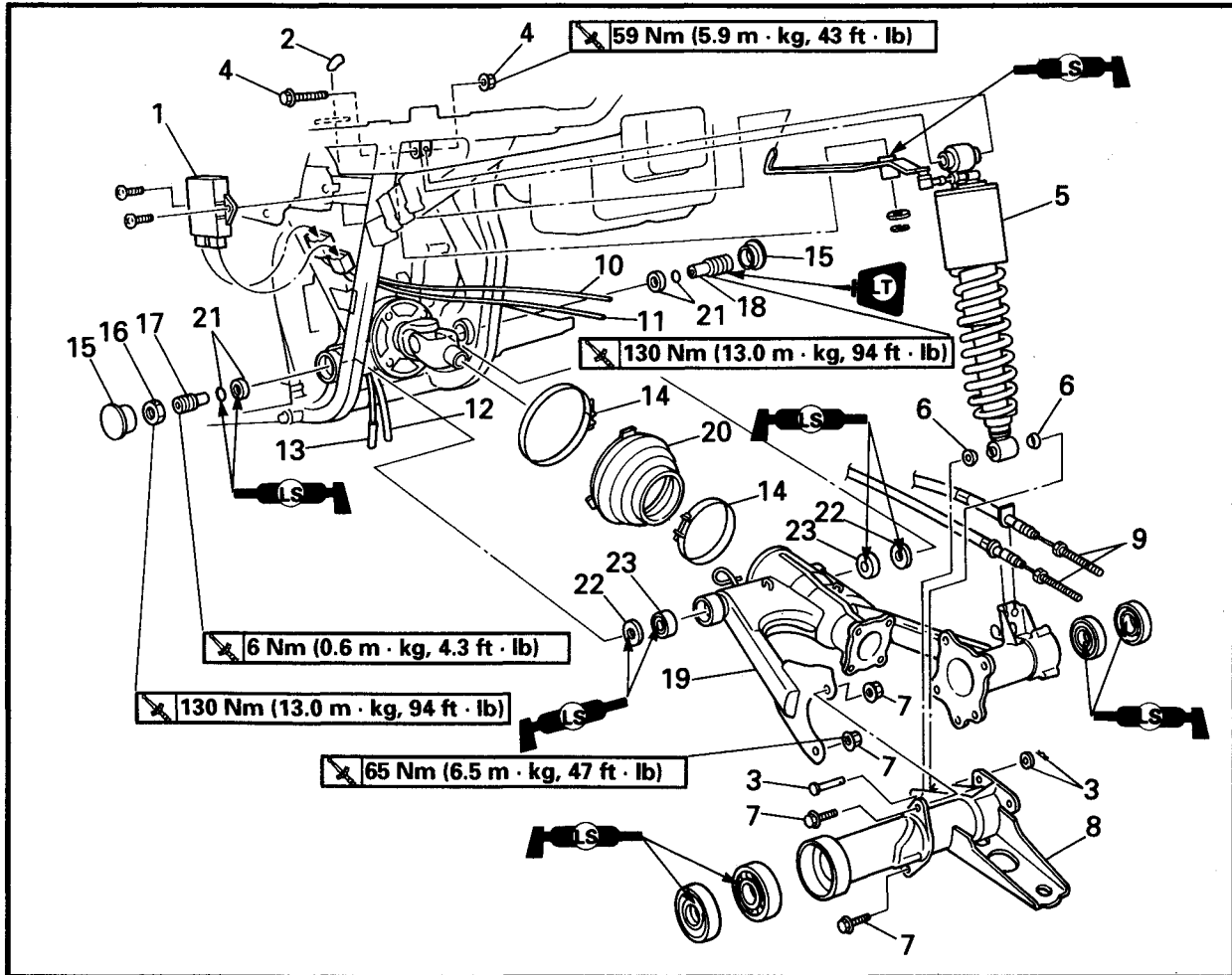

Order	Job name/Part name	Q'ty	Remarks
	Rear shock absorber and swingarm removal		Remove the parts in the order below.
	Brake shoe assembly		Refer to "REAR BRAKE".
	Final drive gear assembly		Refer to "REAR AXLE/FINAL DRIVE GEAR AND DRIVE SHAFT" in CHAPTER 6.
1	CDI unit	1	
2	Lever grip	1	NOTE: Before removing the rear shock absorber, turn the spring preload adjusting lever to "H".
3	Pin / washer / clip	1/1/1	
4	Nut / bolt	1/1	
5	Rear shock absorber	1	
6	Collar	2	
7	Nut / bolt	2/2	
8	Rear axle housing	1	

REAR SHOCK ABSORBER AND SWINGARM

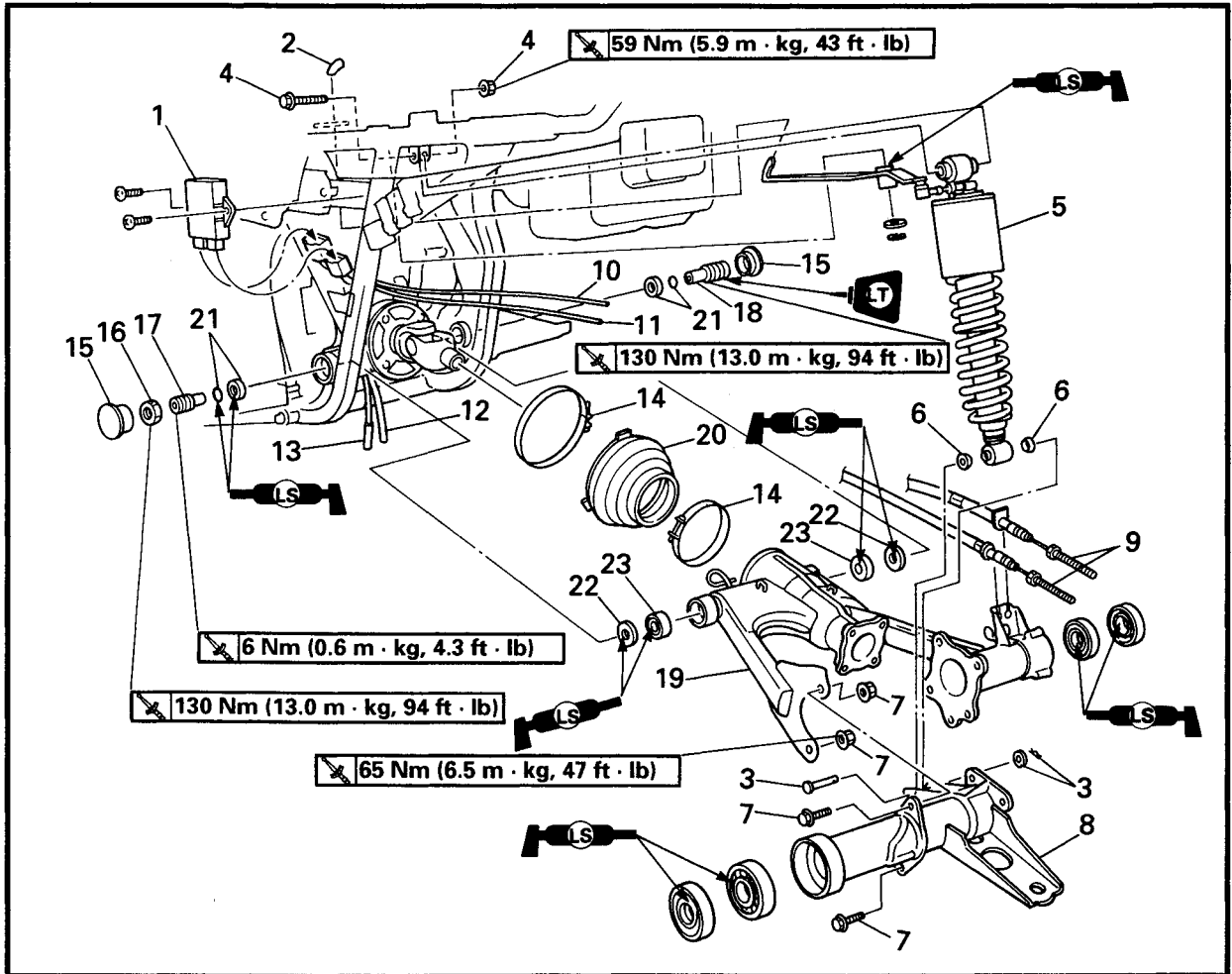

Order	Job name/Part name	Q'ty	Remarks
9	Rear brake cable	2	Pull out of the guides on the swingarm. Refer to "CABLE ROUTING" in CHAPTER 2. Refer to "SWINGARM INSTALLATION". Refer to "SWINGARM REMOVAL/INSTALLATION". Refer to "RUBBER BOOT INSTALLATION". For installation, reverse the removal procedure.
10	Rear brake breather hose	1	
11	Final drive gear case breather hose	1	
12	Carburetor overflow hose	1	
13	Carburetor drain hose	1	
14	Metal clamp	2	
15	Cover	2	
16	Locknut	1	
17	Pivot shaft (left)	1	
18	Pivot shaft (right)	1	
19	Swingarm	1	
20	Rubber boot	1	
21	Collar / O-ring	2/2	
22	Oil seal	2	
23	Taper roller bearing	2	

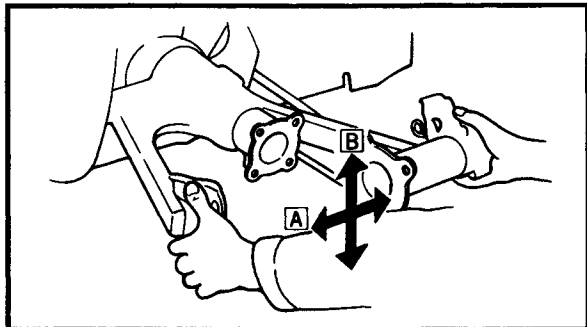

SWINGARM REMOVAL

1. Inspect:

- Swingarm free play

Inspection steps:

- Check the tightening torque of the pivot shafts (swingarm) and locknut (pivot shaft).



Pivot shaft (right):
 130 Nm (13.0 m · kg, 94 ft · lb)
Pivot shaft (left):
 6 Nm (0.6 m · kg, 4.3 ft · lb)
Locknut (pivot shaft-left):
 130 Nm (13.0 m · kg, 94 ft · lb)

- Check the swingarm side play **A** by moving it from side to side.
 If side play is noticeable, check the collar, bearing and frame pivot.
- Check the swingarm vertical movement **B** by moving it up and down.
 If vertical movement is tight, binding or rough, check the bearing, collar and frame pivot.

2. Remove:

- Pivot shafts
- Swingarm

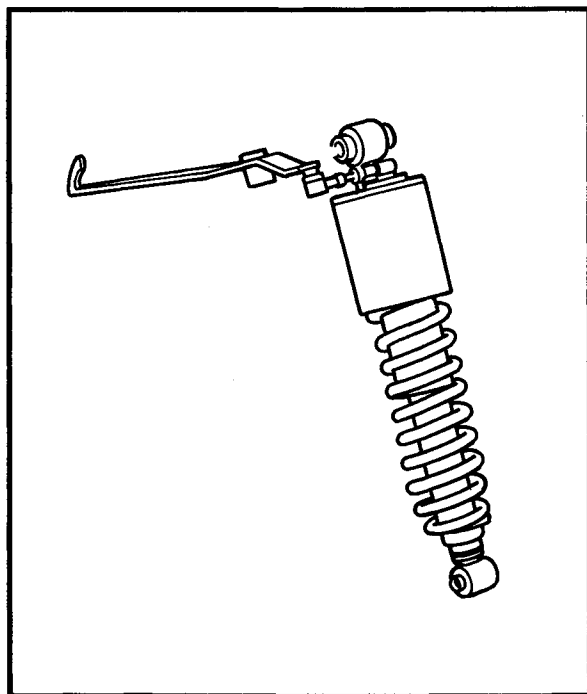

REAR SHOCK ABSORBER INSPECTION

1. Inspect:

- Shock absorber
 Oil leaks → Replace the shock absorber assembly.
- Shock absorber rod
 Bends/damage → Replace the shock absorber assembly.
- Spring
 Fatigue → Replace the shock absorber assembly.
 Move the spring up and down.

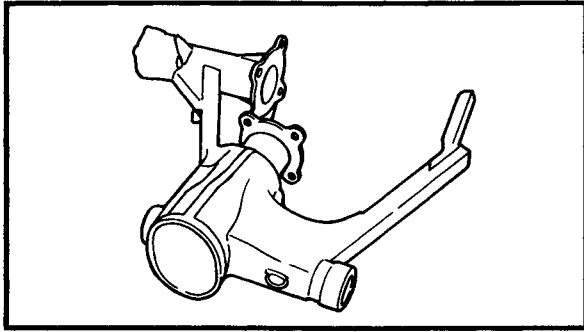

SWINGARM INSPECTION

1. Inspect:

- Swingarm
Bends/cracks/damage → Replace.

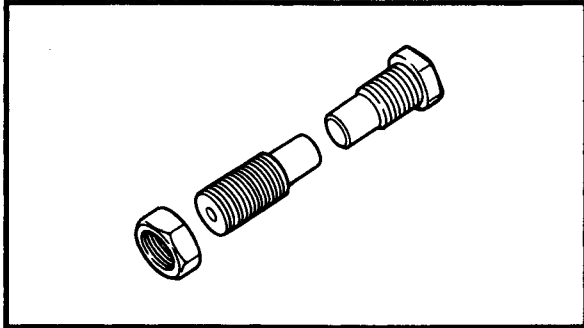

2. Inspect:

- Pivot shafts
Wear/damage → Replace.

NOTE: _____

Wash the swingarm pivoting parts in a solvent.

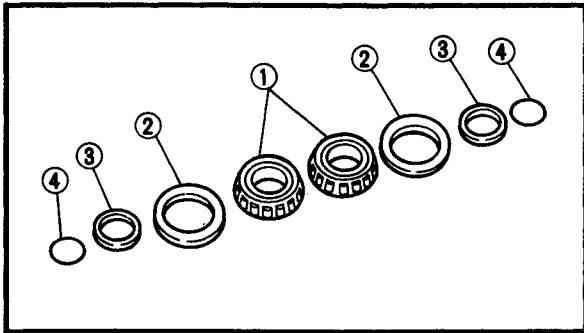

3. Inspect:

- Taper roller bearings ①
Taper roller bearings allow play in the swingarm or the bearings turn roughly → Replace.
- Oil seals ②
- Collars ③
- O-rings ④
Wear/damage → Replace.

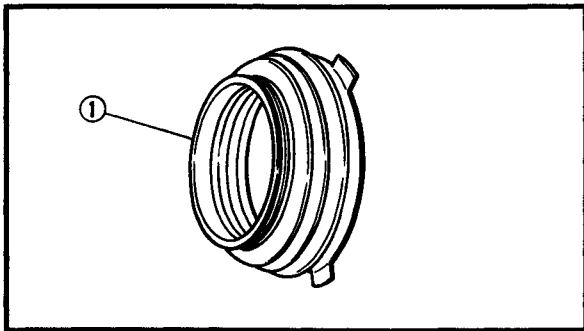

RUBBER BOOT INSPECTION

1. Inspect:

- Rubber boot ①
Damage → Replace.

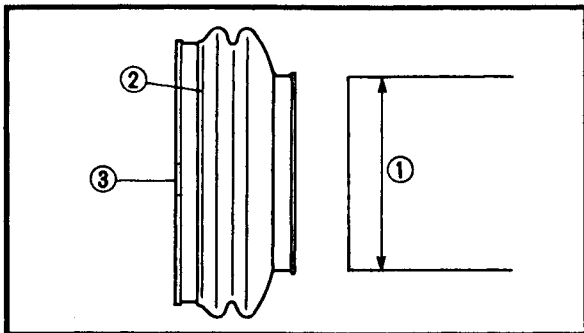

RUBBER BOOT INSTALLATION

1. Apply:

- Adhesive (for rubber)
(to the swingarm end ①)

2. Install:

- Rubber boot ②

NOTE: _____

Be sure to position the rubber boot so that the tang ③ faces towards the left.

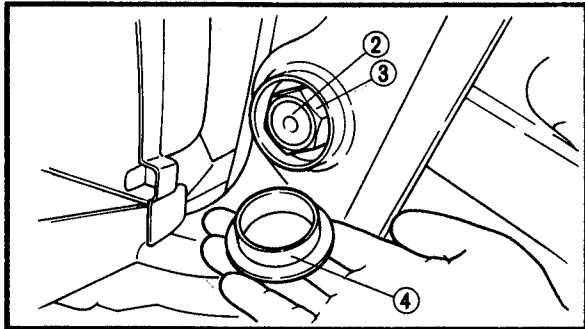
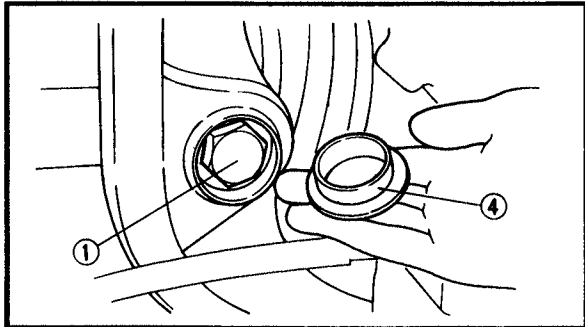

SWINGARM INSTALLATION

1.Install:

- Swingarm
- Pivot shaft (right) ①
- Pivot shaft (left) ②
- Locknut (pivot shaft-left) ③
- Covers ④

NOTE:

Finger tighten the pivot shafts and locknut; do not torque them at this point.

2.Tighten:

- Pivot shafts

Tightening steps:

- Tighten the pivot shaft (right) to specification.

	Pivot shaft (right) ①: 130 Nm (13.0 m • kg, 94 ft • lb)
---	---

- Tighten the pivot shaft (left) until it contacts the collar.

	Pivot shaft (left) ②: 6 Nm (0.6 m • kg, 4.3 ft • lb)
---	--

- Tighten the locknut (pivot shaft-left) to specification.

	Locknut (pivot shaft-left) ③: 130 Nm (13.0 m • kg, 94 ft • lb)
---	--

3.Install:

- Metal clamps

NOTE:

- Seen from the rear of the vehicle, the metal clamps should be positioned as shown in the illustrations.
- When installing the metal clamps, be sure that the swingarm is parallel to the vehicle.

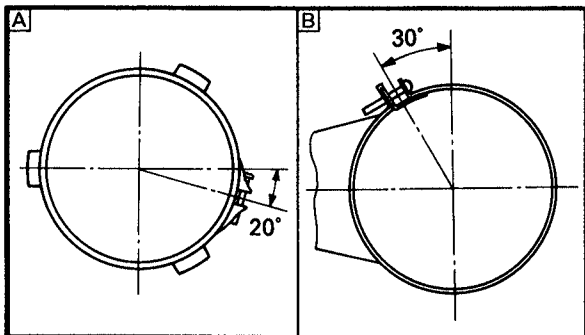

- Ⓐ Engine side
- Ⓑ Swingarm side



EB800000

ELECTRICAL

ELECTRICAL COMPONENTS

- | | | | |
|---------------------------|----------------------------------|--------------------------|-------------------------|
| ① Indicator light | ⑦ Battery | ⑬ Fan motor control unit | ⑳ 4WD switch |
| ② Main switch | ⑧ Taillight | ⑭ CDI unit | ㉑ Gear motor |
| ③ Rear brake switch | ⑨ Starter relay | ⑮ Rectifier/regulator | ㉒ Fan |
| ④ Handlebar switch (left) | ⑩ Reverse relay | ⑯ Neutral switch | ㉓ Headlight |
| ⑤ Ignition coil | ⑪ Starting circuit cut-off relay | ⑰ Reverse switch | ㉔ Diode |
| ⑥ Fuses | ⑫ Fan motor relay | ⑱ Thermo unit | ㉕ Terminal |
| | | ⑲ Circuit breaker (fan) | ㉖ 2WD/4WD select switch |

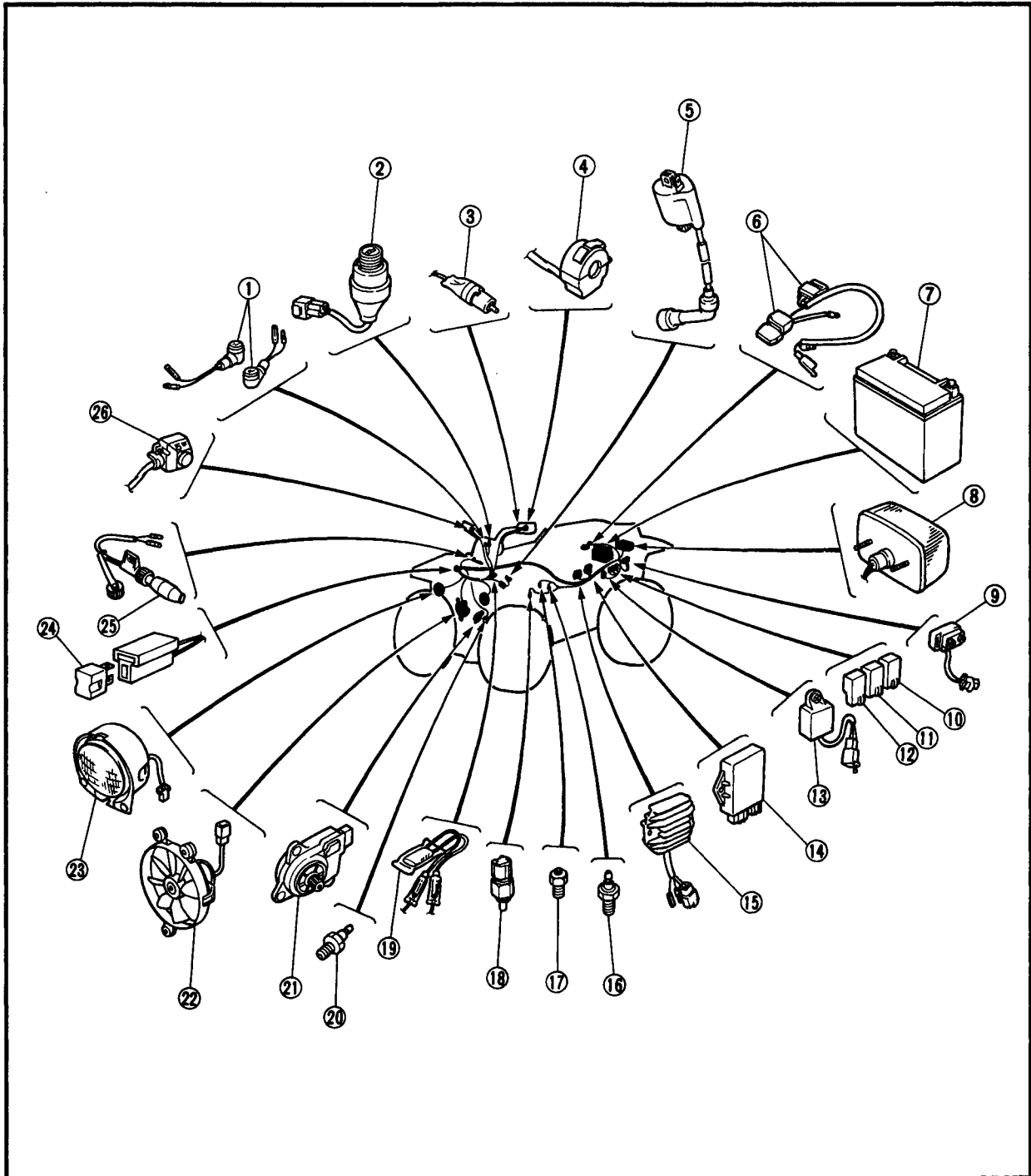

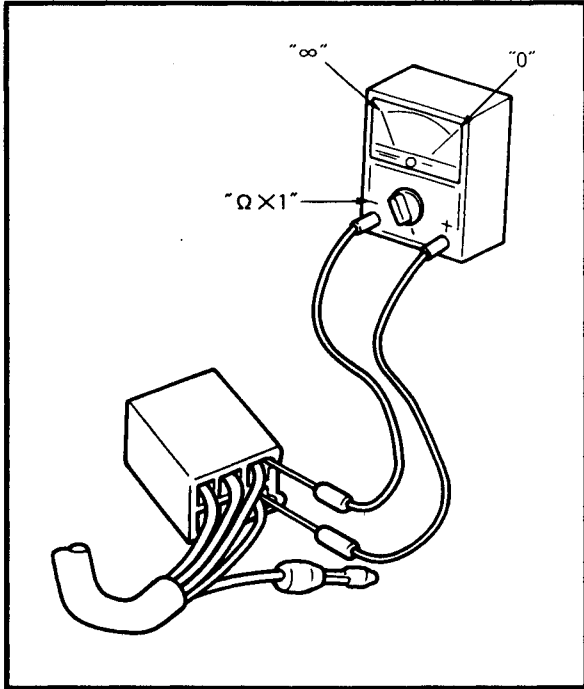

SWITCH INSPECTION

SWITCH INSPECTION

Use a pocket tester to check the terminals for continuity. If the continuity is faulty as any point, replace the switch.



Pocket tester:
P/N. YU-03112, 90890-03112

NOTE:

- Set the pocket tester to "0" before starting the test.
- The pocket tester should be set to the "x 1" Ω range when testing the switch for continuity.
- Turn the switch on and off a few times when checking it.

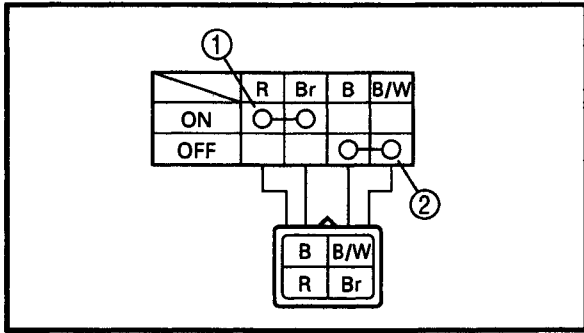

INSPECTING A SWITCH SHOWN IN THE MANUAL

The terminal connections for switches (main switch, handlebar switch, engine stop switch, light switch, etc.) are shown in a chart similar to the one on the left.

This chart shows the switch positions in the column and the switch lead colors in the top row.

For each switch position, "○—○" indicates the terminals with continuity.

The example chart shows that:

- ① There is continuity between the "Black and Black/White" leads when the switch is set to "OFF".
- ② There is continuity between the "Red and Brown" leads when the switch is set to "ON".

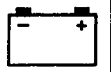

SWITCH CONTINUITY INSPECTION

Refer to "SWITCH INSPECTION" and check for continuity between lead terminals.

Poor connection, no continuity → Correct or replace.

* The coupler locations are circled.

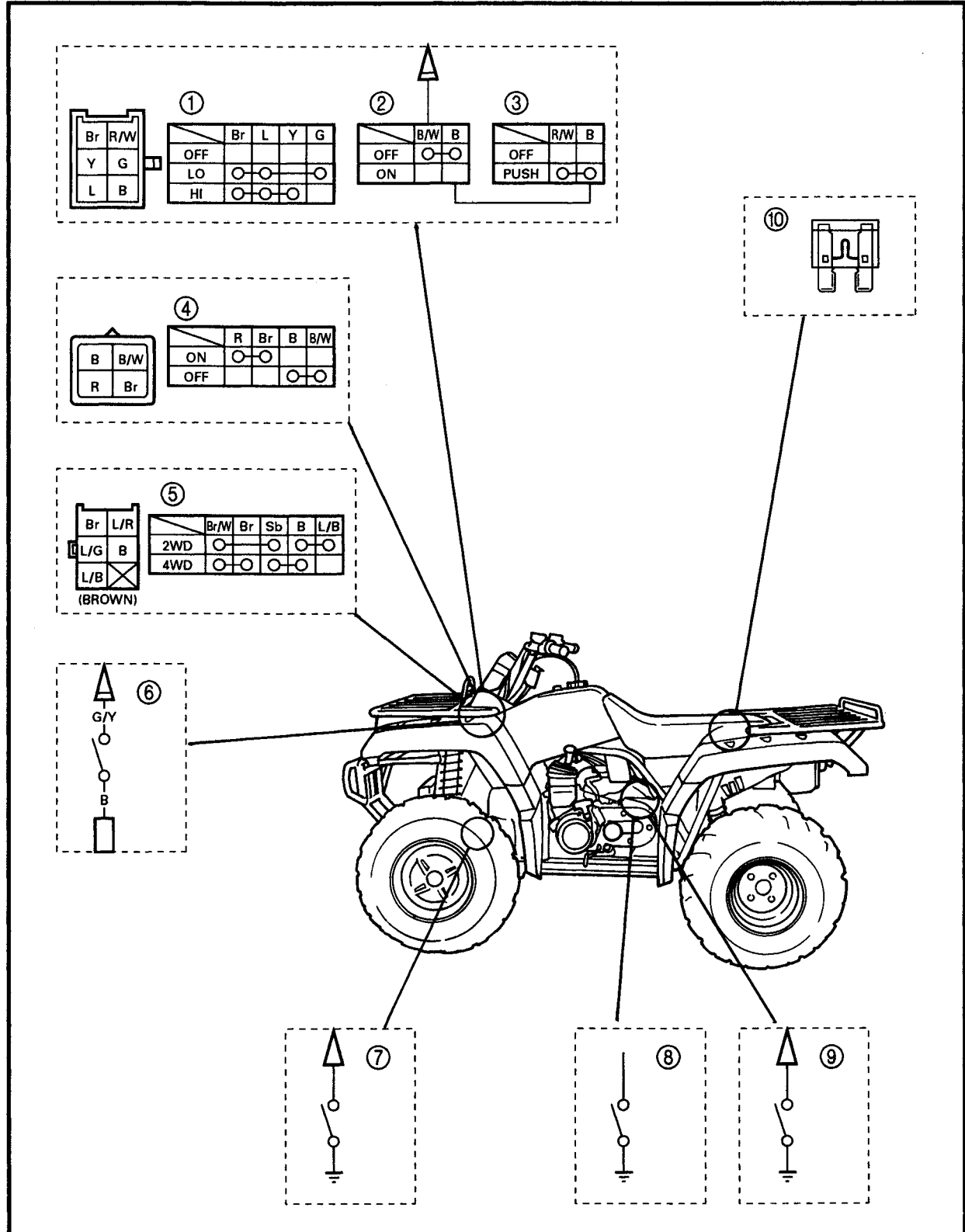

SWITCH INSPECTION

ELEC

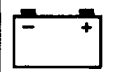

- ① Lights switch
- ② Engine stop switch
- ③ Starter switch
- ④ Main switch
- ⑤ 2WD/4WD select switch
- ⑥ Rear brake switch
- ⑦ 4WD switch
- ⑧ Reverse switch
- ⑨ Neutral switch
- ⑩ Fuse

EB802000

IGNITION SYSTEM

CIRCUIT DIAGRAM

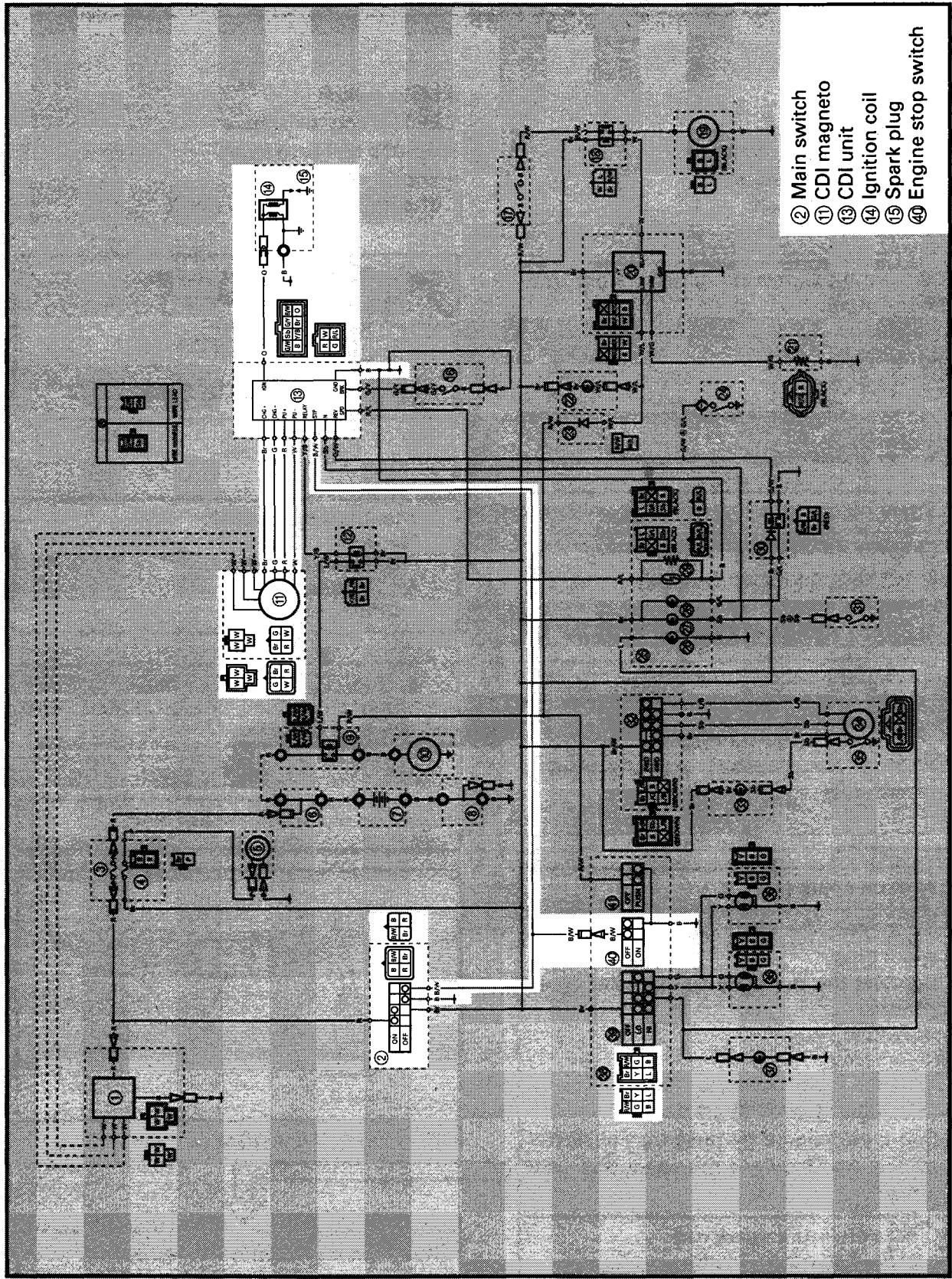

- ② Main switch
- ① CDI magneto
- ③ CDI unit
- ④ Ignition coil
- ⑤ Spark plug
- ⑥ Engine stop switch



EB802010
TROUBLESHOOTING

IF THE IGNITION SYSTEM FAILS TO OPERATE (NO SPARK OR INTERMITTENT SPARK):

Procedure

Check:

1. Spark plugs
2. Ignition spark gap
3. Spark plug cap resistance
4. Ignition coil resistance
5. Engine stop switch
6. Main switch
7. Pickup coil resistance
8. Source coil resistance
9. Wiring connection
(the entire ignition system)

NOTE:

- Remove the following part(s) before troubleshooting:
 - 1) Seat
 - 2) Front carrier
 - 3) Front fender
- Use the following special tool(s) for troubleshooting.



Dynamic spark tester:
P/N. YM-34487
Ignition checker:
P/N. 90890-06754
Pocket tester:
P/N. YU-03112, 90890-03112

1. Spark plug

- Check the spark plug condition.
- Check the spark plug type.
- Check the spark plug gap.
Refer to "SPARK PLUG INSPECTION" in CHAPTER 3.

Standard spark plug:
for USA
DP8EA-9/NGK
for Canada
DPR8EA-9/NGK



Spark plug gap:
0.8 ~ 0.9 mm (0.031 ~ 0.035 in)

INCORRECT



CORRECT

Repair or replace the spark plug.

for USA/CDN

2. Ignition spark gap

- Disconnect the spark plug cap from the spark plug.
- Connect the dynamic spark tester ① as shown.
- ② Spark plug cap
- ③ Spark plug
- Turn the main switch to "ON".
- Check the ignition spark gap.
- Crank the engine by pushing the starter switch, and increase the spark gap until a misfiring occurs.

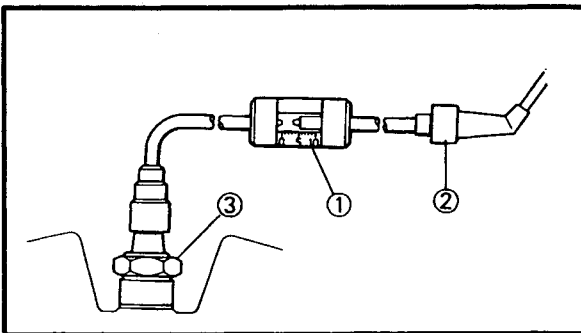

MEETS SPECIFICATION



Minimum spark gap:
6.0 mm (0.24 in)

The ignition system is not faulty.



for EUR/AUS

2. Ignition spark gap

- Disconnect the spark plug cap from the spark plug.
- Connect the ignition checker ① as shown.
- ② Spark plug cap
- Turn the main switch to "ON".
- Check the ignition spark gap ③.
- Crank the engine by pushing the starter switch and increase the spark gap until a misfire occurs.

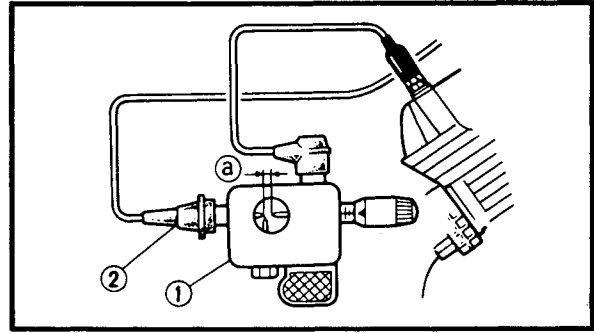

Minimum spark gap:
6.0 mm (0.24 in)

OUT OF SPECIFICATION OR NO SPARK

MEETS SPECIFICATION

The ignition system is not faulty.

3. Spark plug cap resistance

- Remove the spark plug cap.
- Connect the pocket tester ($\Omega \times 1k$) to the spark plug cap.

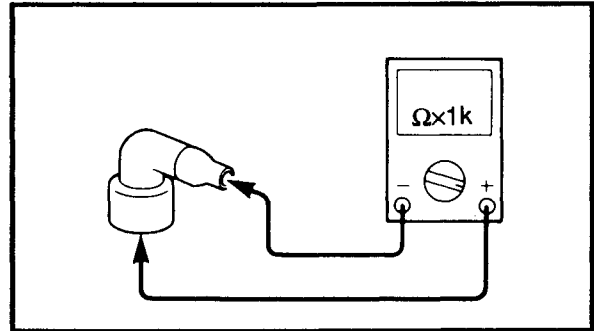

- Check the spark plug cap has the specified resistance.

Spark plug cap resistance:
10 k Ω at 20 °C (68°F)

OUT OF SPECIFICATION

Replace the spark plug cap.

MEETS SPECIFICATION
*



4. Ignition coil resistance

- Disconnect the ignition coil connector from the wire harness.
- Connect the pocket tester ($\Omega \times 1$) to the ignition coil.

- Check the primary coil has the specified resistance.

 **Primary coil resistance:**
0.18 ~ 0.28 Ω at 20 °C (68°F)

- Connect the pocket tester ($\Omega \times 1k$) to the ignition coil.

Tester (+) lead → Orange lead terminal
Tester (-) lead → Ignition coil base

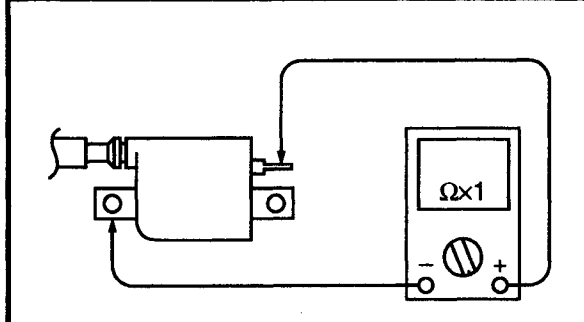

Tester (+) lead → Ignition coil base
Tester (-) lead → Spark plug lead

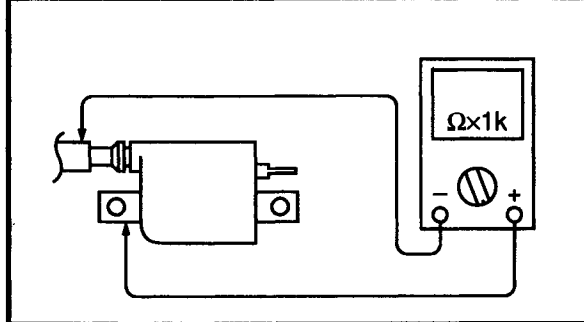

- Check the secondary coil has the specified resistance.

 **Secondary coil resistance:**
6.32 ~ 9.48 k Ω at 20 °C (68°F)

BOTH MEET SPECIFICATION

OUT OF SPECIFICATION



Replace the ignition coil.

5. Engine stop switch
Refer to "SWITCH INSPECTION".

CORRECT

INCORRECT



Replace handlebar switch (left).

6. Main switch
Refer to "SWITCH INSPECTION".

CORRECT

*

INCORRECT



Replace neutral switch.



7. Pickup coil resistance

- Disconnect the CDI magneto coupler from the wire harness.
- Connect the pocket tester ($\Omega \times 100$) to the pickup coil terminal.

Tester (+) lead → Red terminal ①
Tester (-) lead → White terminal ②

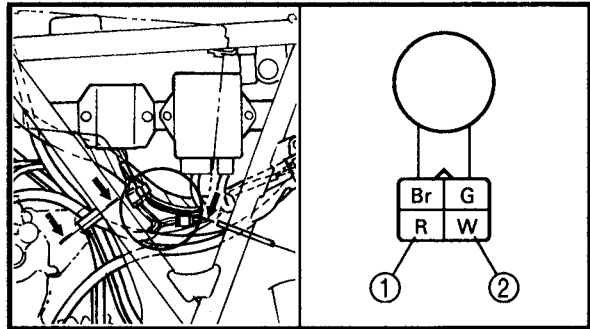

- Check the pickup coil for the specified resistance.

Pickup coil resistance:
459 ~ 561 Ω at 20°C (68°F)
(Red - White)

OUT OF SPECIFICATION

Replace the pickup coil.



8. Source coil resistance

- Disconnect the source coil coupler from the wire harness.
- Connect the pocket tester ($\Omega \times 100$) to the source coil terminal.

Tester (+) lead → Brown terminal ①
Tester (-) lead → Green terminal ②

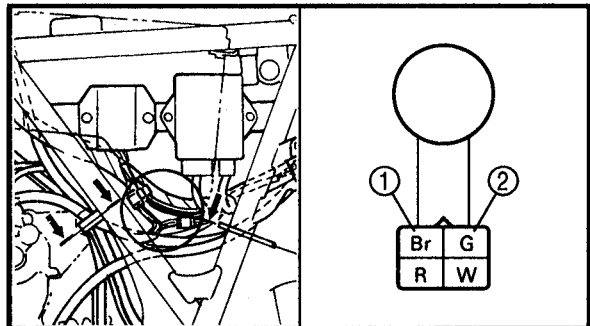

- Check the source coil for the specified resistance.

Source coil resistance:
270 ~ 330 Ω at 20°C (68°F)
(Brown - Green)

OUT OF SPECIFICATION

Replace the source coil.



9. Wiring connection

- Check the connections of the entire ignition system.

Refer to "CIRCUIT DIAGRAM".

POOR CONNECTION

Properly connect the ignition system.

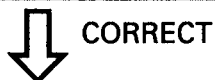

Replace the CDI unit.

EB803000

ELECTRIC STARTING SYSTEM
CIRCUIT DIAGRAM

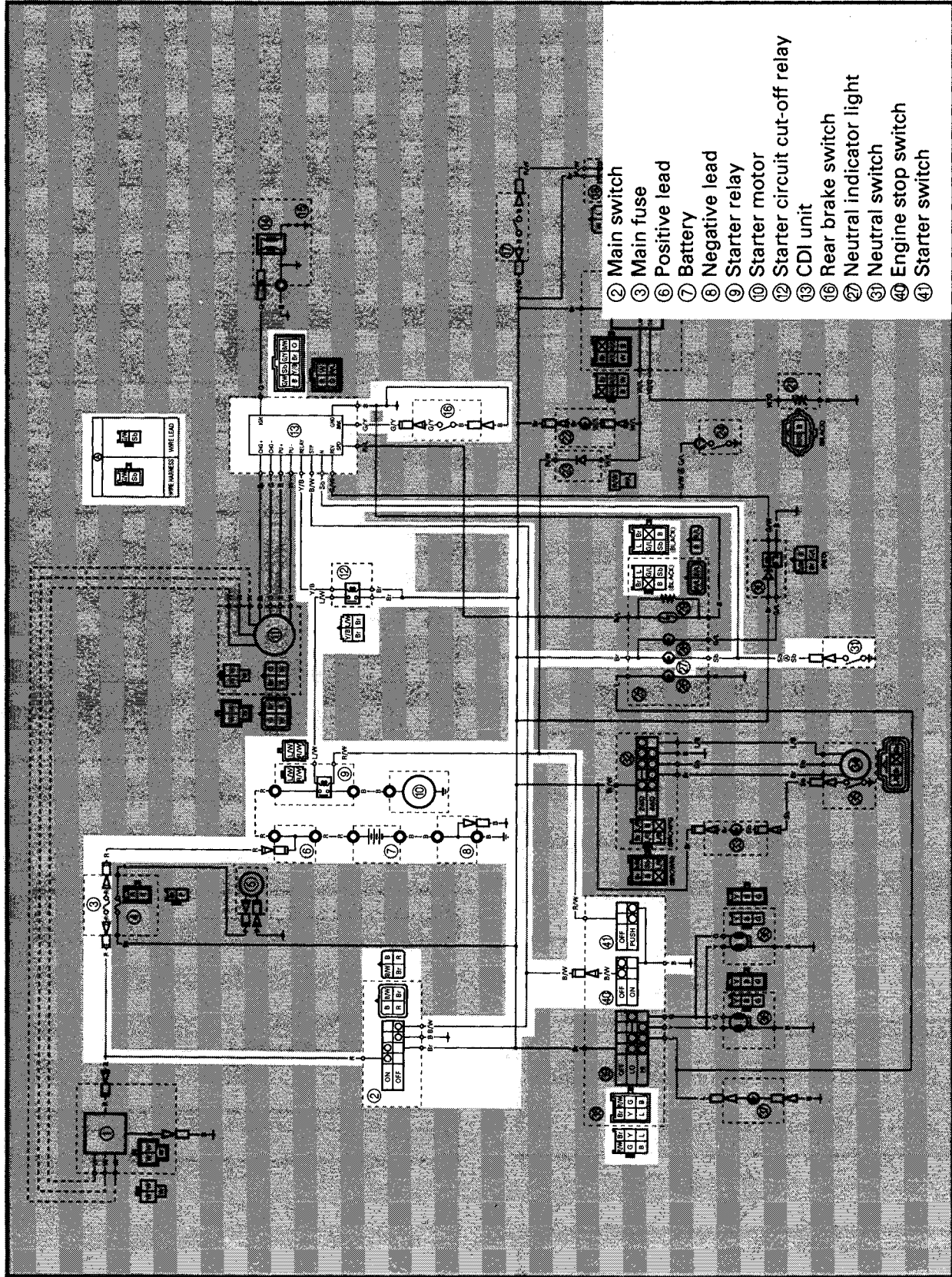

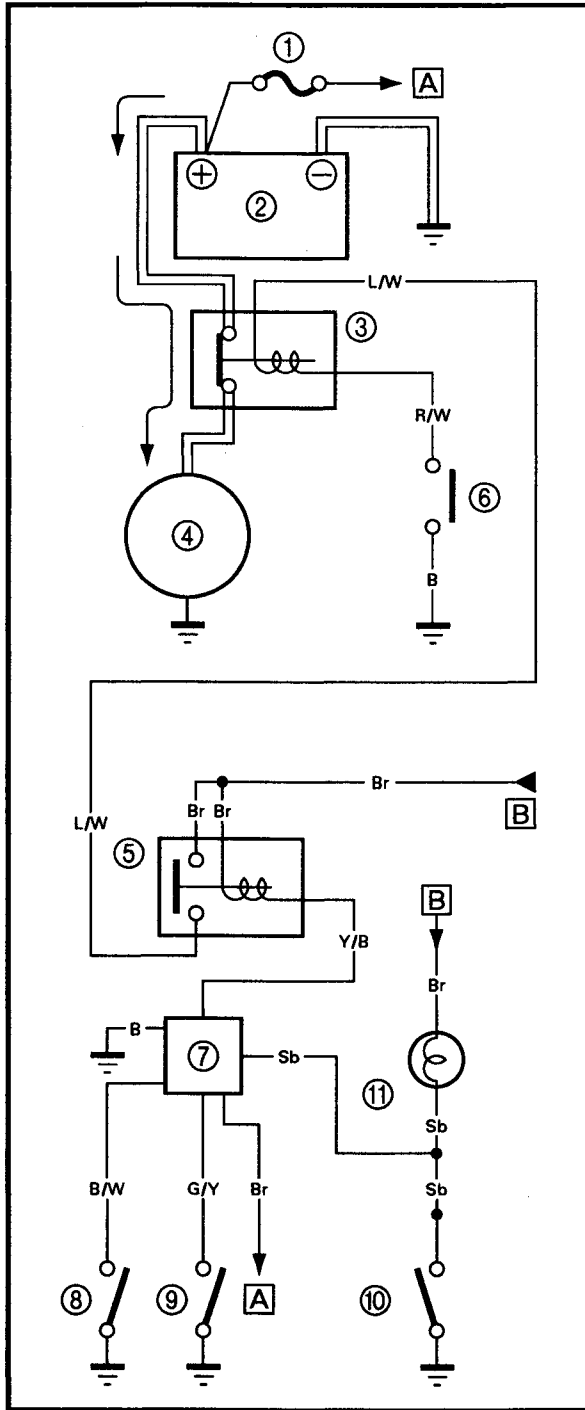
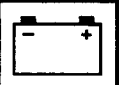

STARTING CIRCUIT OPERATION

The starting circuit on this model consists of the starter motor, starter relay, starting circuit cut-off relay, rear brake switch, CDI unit and neutral switch. If the main switch is on and the engine stop switch is in the RUN position the starter motor can be operated only if:

- The transmission is in neutral (the neutral switch is closed).
- or**
- You pull in the rear brake lever (the rear brake switch is ON).

The starting circuit cut-off relay prevents the starter from operating when the select lever is in gear or in reverse and the rear brake lever is free. In this instance, the starting circuit cut-off relay is off so that current cannot reach the starter motor.

- ① Fuse
- ② Battery
- ③ Starter relay
- ④ Starter motor
- ⑤ Starting circuit cut-off relay
- ⑥ Start switch
- ⑦ CDI unit
- ⑧ Engine stop switch
- ⑨ Rear brake switch
- ⑩ Neutral switch
- ⑪ Neutral indicator light
- Ⓐ TO MAIN SWITCH
- Ⓑ FROM MAIN SWITCH



EB803020
TROUBLESHOOTING

IF THE STARTER MOTOR FAILS TO OPERATE:

Procedure

Check:

- | | |
|---|---|
| <ol style="list-style-type: none"> 1.Fuse (main) 2.Battery 3.Starter motor 4.Starting circuit cut-off relay 5.Starter relay 6.Main switch | <ol style="list-style-type: none"> 7.Engine stop switch 8.Neutral switch 9.Rear brake switch 10.Start switch 11.Wiring connection
(the entire starting system) |
|---|---|

NOTE:

- Remove the following part(s) before troubleshooting:
 - 1)Seat
 - 2)Front carrier
 - 3)Front fender
- Use the following special tool(s) for troubleshooting.

	Pocket tester: P/N. YU-03112, 90890-03112
--	---

EB802011

1.Fuse (main)
Refer to "SWITCH INSPECTION".

↓ CONTINUITY

NO CONTINUITY

↓

Replace the fuse.

EB802012

2.Battery
<ul style="list-style-type: none"> • Check the battery condition. Refer to "BATTERY INSPECTION" in CHAPTER 3.
Open-circuit voltage: 12.8 V or more at 20 °C (68 °F)

↓ CORRECT

*

INCORRECT

↓

<ul style="list-style-type: none"> • Clean the battery terminals. • Recharge or replace the battery.
--



3. Starter motor

- Connect the battery positive terminal ① and starter motor cable ② using a jumper lead ③ *.
- Check the operation of the starter motor.

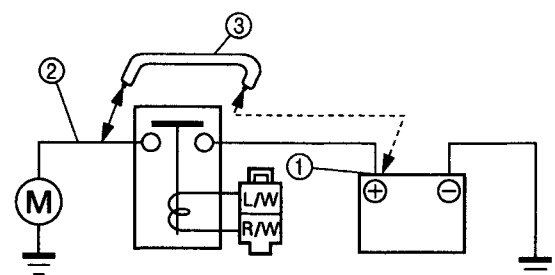

*

⚠ WARNING

- A wire that is used as a jumper lead must have the equivalent capacity or more as that of the battery lead, otherwise the jumper lead may burn.
- This check is likely to produce sparks, so be sure that no flammable gas or fluid is in the vicinity.

DOES NOT TURN



Repair or replace the starter motor.



4. Starting circuit cut-off relay

- Remove the starting circuit cut-off relay from the wire harness.
- Connect the pocket tester ($\Omega \times 1$) and the battery (12V) to the starting circuit cut-off relay terminals.

Battery (+) terminal → **Brown terminal** ①
Battery (-) terminal → **Yellow/Black terminal** ②

Tester (+) lead → **Brown terminal** ③
Tester (-) lead → **Blue/White terminal** ④

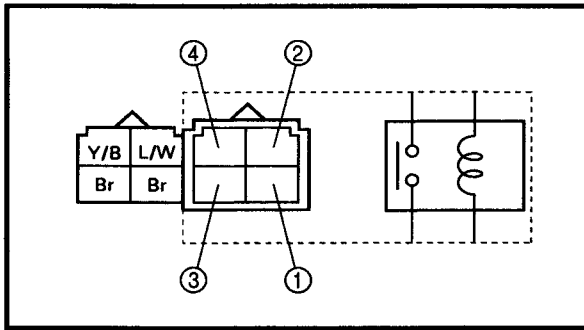

- Check the starting circuit cut-off relay for continuity.

NO CONTINUITY



Replace the starting circuit cut-off relay.

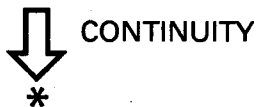



5. Starter relay

- Remove the starter relay from the wire harness.
- Connect the pocket tester ($\Omega \times 1$) and the battery (12 V) to the starter relay terminals.

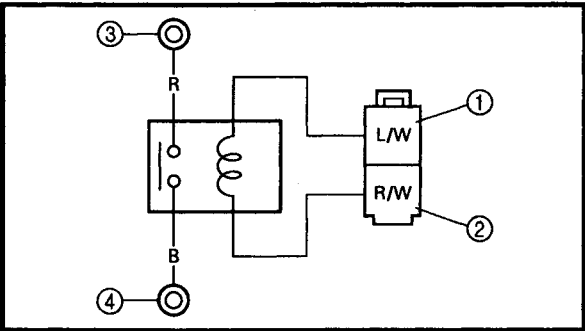

Battery (+) terminal → Blue/White terminal ①
Battery (-) terminal → Red/White terminal ②

Tester (+) lead → Red terminal ③
Tester (-) lead → Black terminal ④

- Check the starter relay for continuity.

NO CONTINUITY

Replace the starter relay.

CONTINUITY

6. Main switch
 Refer to "SWITCH INSPECTION".

INCORRECT

Replace main switch.

CORRECT

7. Engine stop switch
 Refer to "SWITCH INSPECTION".

INCORRECT

Replace handlebar switch (right).

CORRECT

8. Neutral switch
 Refer to "SWITCH INSPECTION".

INCORRECT

Replace neutral switch.

CORRECT



9.Rear brake switch
Refer to "SWITCH INSPECTION".

INCORRECT



Replace rear brake switch.



10.Start switch
Refer to "SWITCH INSPECTION".

INCORRECT



Replace handlebar switch (left).



EB803028

11.Wiring connection
• Check the connections of the entire starting system.
Refer to "CIRCUIT DIAGRAM".

POOR CONNECTION



Properly connect the starting system.

STARTER MOTOR

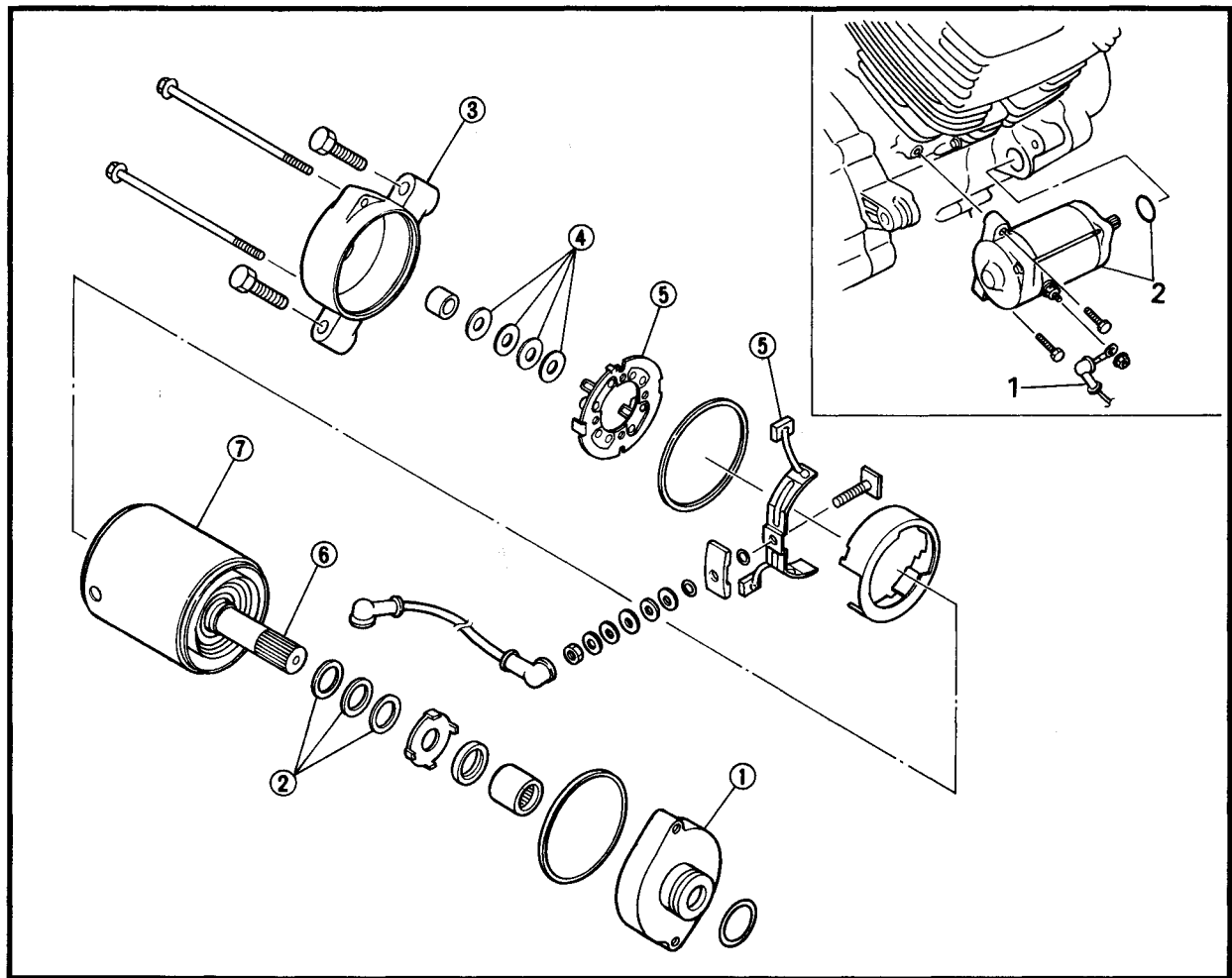

Order	Job name/Part name	Q'ty	Remarks
	Starter motor removal		Remove the parts in the order below.
1	Starter motor lead	1	
2	Starter motor / O-ring	1/1	
	Starter motor disassembly		Disassemble the parts in the order below.
①	Bracket 1	1	Refer to "STARTER MOTOR ASSEMBLY".
②	Washer kit		
③	Bracket 2	1	
④	Shims		
⑤	Brush seat 1/brush seat 2	1/2	
⑥	Armature coil	1	
⑦	Yoke	1	
			For assembly, reverse the disassembly procedure.

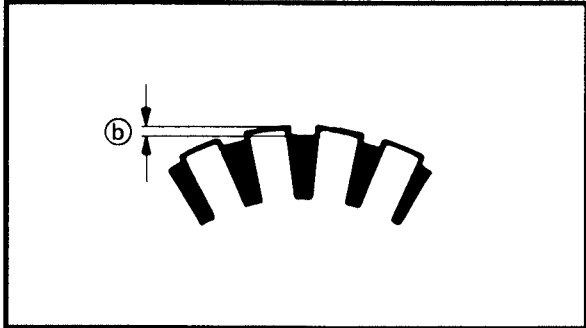
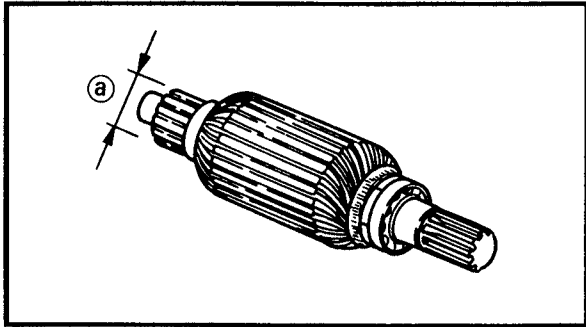

STARTER MOTOR INSPECTION

1. Inspect:
- Commutator
Dirty → Clean it with #600 grit sandpaper.
2. Measure:
- Commutator diameter Ⓐ
Out of specification → Replace the starter motor.

 **Outside diameter:**
28 mm (1.10 in)
<Wear limit:>
<27 mm (1.06 in)>

3. Measure:
- Mica undercut Ⓑ
Out of specification → Scrape the mica using a hacksaw blade.

 **Mica undercut:**
0.7 mm (0.028 in)

NOTE: _____
Scrape the mica to the proper measurement using a hacksaw blade which has been grounded to fit the commutator.

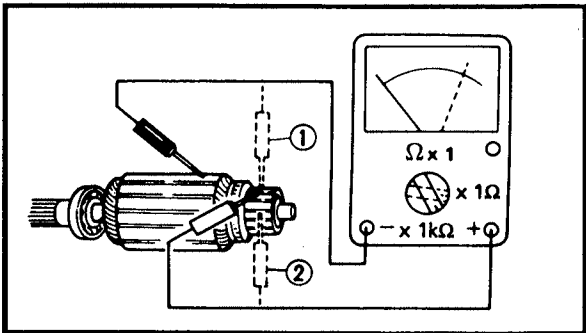

4. Inspect:
- Armature coil (insulation/continuity)
Defects → Replace the starter motor.

Armature coil inspecting steps:

- Connect the pocket tester for the continuity check ① and insulation check ②.
- Measure the armature resistances.

 **Armature coil resistance:**
Continuity check ①:
0 Ω at 20 °C (68 °F)
Insulation check ②:
More than 1 MΩ at 20 °C (68 °F)

- If the resistance is incorrect, replace the starter motor.

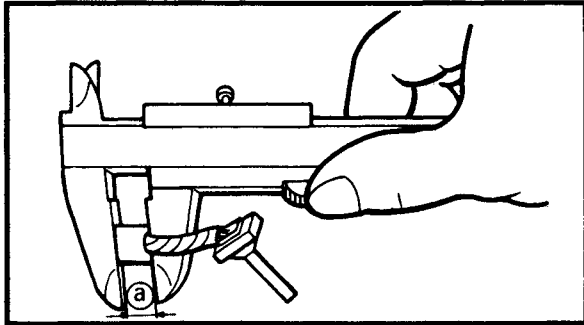

5.Measure:

- Brush length ③ (each)
Out of specification → Replace the brush.



Brush length:
12.5 mm (0.49 in)
<Wear limit:>
<5 mm (0.20 in)>

6.Measure:

- Brush spring force
Fatigue/out of specification → Replace as a set.



Brush spring force:
780 ~ 1,021 g (27.5 ~ 36.0 oz)

7.Inspect:

- Oil seal
- Bushing
- O-rings
Wear/damage → Replace.

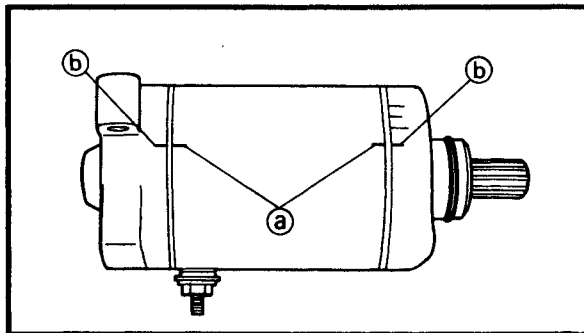

STARTER MOTOR ASSEMBLY

1.Install:

- Yoke
- Bracket

NOTE: _____
Align the match marks ③ on the yoke with the match marks ④ on the brackets.



EB804000

CHARGING SYSTEM
CIRCUIT DIAGRAM

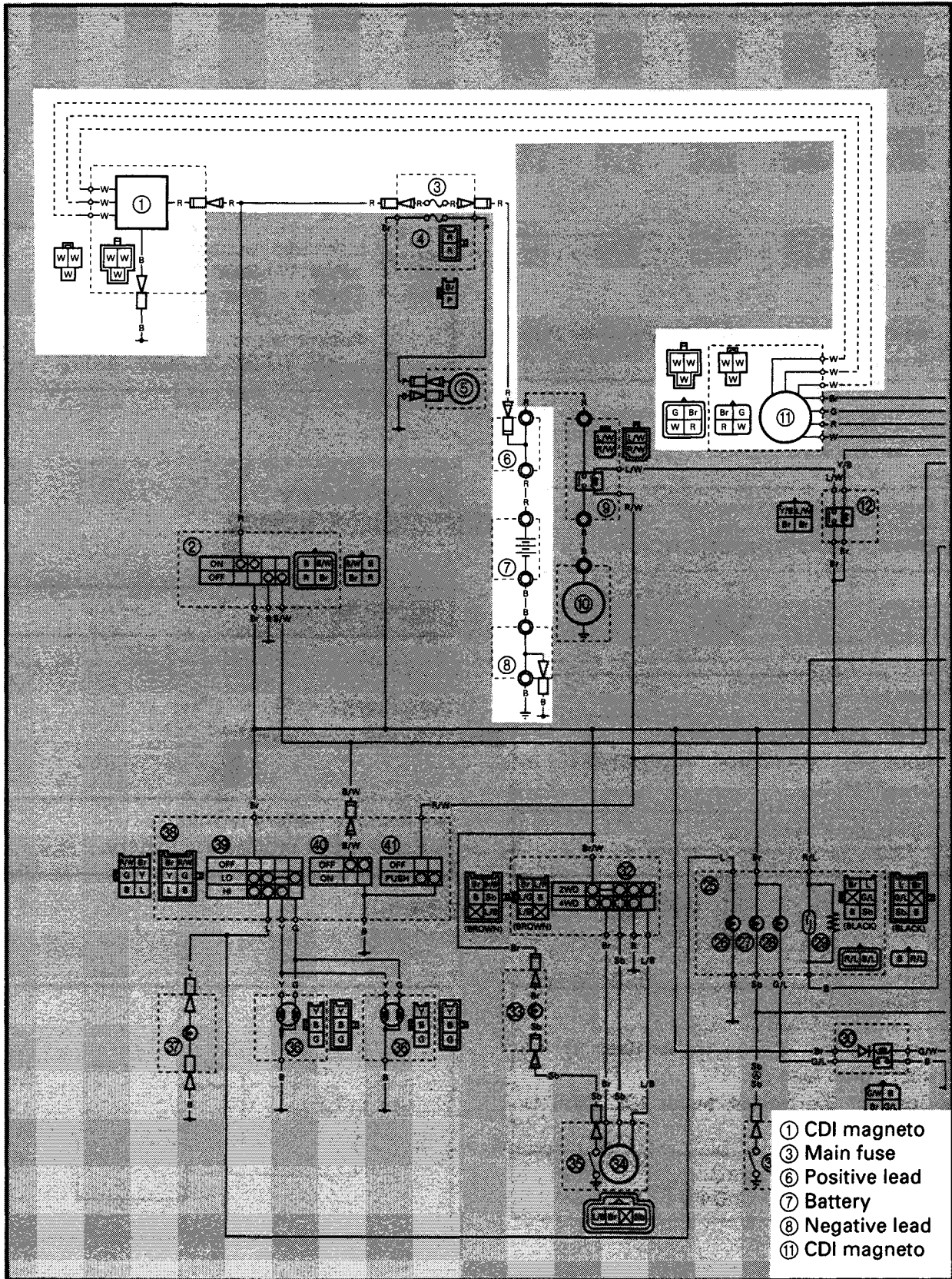

- ① CDI magneto
- ③ Main fuse
- ⑥ Positive lead
- ⑦ Battery
- ⑧ Negative lead
- ⑪ CDI magneto



EB804010
TROUBLESHOOTING

IF THE BATTERY IS NOT CHARGED:

Procedure

Check:

- | | |
|---|---|
| <ul style="list-style-type: none"> 1. Fuse (main) 2. Battery 3. Charging voltage | <ul style="list-style-type: none"> 4. Stator coil resistance 5. Wiring connections
(the entire charging system) |
|---|---|

NOTE:

- Remove the following part(s) before troubleshooting:
 - 1) Seat
- Use the following special tool(s) for troubleshooting.



Inductive tachometer:
P/N. YU-8036-A
Engine tachometer:
P/N. 90890-03113
Pocket tester:
P/N. YU-03112, 90890-03112

EB802011

1. Fuse (main)
Refer to "SWITCH INSPECTION".



NO CONTINUITY



Replace the fuse.

EB802012

2. Battery

- Check the battery condition.
Refer to "BATTERY INSPECTION" in CHAPTER 3.

Open-circuit voltage:
12.8 V or more at 20 °C (68 °F)



INCORRECT



- Clean the battery terminals.
- Recharge or replace the battery.

EB804011

3. Charging voltage

- Connect the engine tachometer to the spark plug lead #1.
- Connect the pocket tester (DC 20V) to the battery.

Tester (+) lead → Battery (+) terminal
Tester (-) lead → Battery (-) terminal

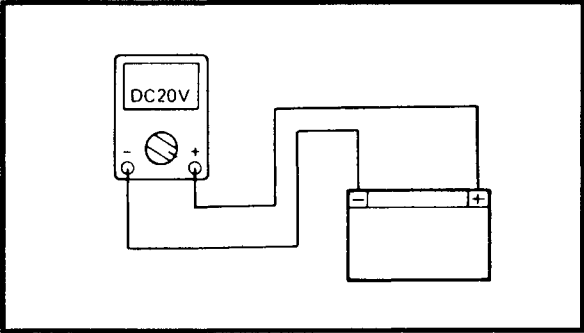

- Start the engine and accelerate to about 3,000 r/min.

 **Charging voltage:**
14 V at 3,000 r/min

NOTE: _____
Use a fully charged battery.

MEETS SPECIFICATION



The charging circuit is not faulty.

OUT OF SPECIFICATION



EB804012

4. Stator coil resistance

- Disconnect the AC magneto coupler from the wire harness.
- Connect the pocket tester ($\Omega \times 1$) to the stator coils.

Tester (+) lead → White terminal ①
Tester (-) lead → White terminal ②

Tester (+) lead → White terminal ①
Tester (-) lead → White terminal ③

- Measure the stator coil resistance.

 **Stator coil resistance:**
0.70 ~ 0.86 Ω at 20 °C (68 °F)

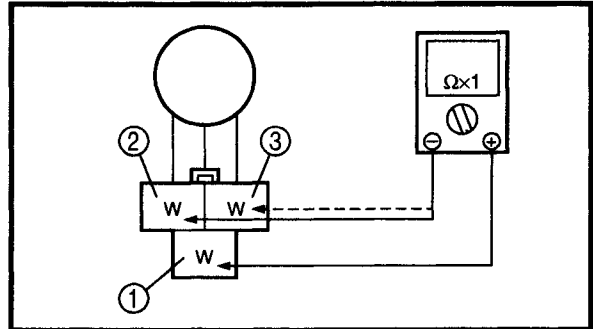

OUT OF SPECIFICATION



Replace the stator coil assembly.

BOTH MEET SPECIFICATION



EB804015

5. Wiring connections

- Check the connections of the entire charging system. Refer to "CIRCUIT DIAGRAM".

POOR CONNECTION



Properly connect the charging system.

CORRECT



Replace the rectifier/regulator.

EB805010
TROUBLESHOOTING

IF THE HEADLIGHT, TAIL LIGHT AND/OR METER LIGHT FAIL TO COME ON:

Procedure

Check:

- 1.Fuse (main)
- 2.Battery
- 3.Main switch

- 4.Lights switch
- 5.Wiring connections
(the entire lighting system)

NOTE:

- Remove the following part(s) before troubleshooting:
 - 1)Seat
 - 2)Front carrier
 - 3)Front fender
- Use the following special tool(s) for troubleshooting.



Pocket tester:
P/N. YU-03112, 90890-03112

EB802011

1.Fuse (main)
Refer to "SWITCH INSPECTION".

CONTINUITY

NO CONTINUITY

Replace the fuse.

EB802012

2.Battery

- Check the battery condition.
Refer to "BATTERY INSPECTION" in CHAPTER 3.

Open-circuit voltage:
12.8 V or more at 20 °C (68 °F)

CORRECT
*

INCORRECT

- Clean the battery terminals.
- Recharge or replace the battery.



3. Main switch
Refer to "SWITCH INSPECTION".

INCORRECT



Replace main switch.



4. Lights switch
Refer to "SWITCH INSPECTION".



Lights switch is faulty, replace handlebar switch (left).



EB805013
5. Wiring connection
• Check the connections of the entire lighting system.
Refer to "WIRING DIAGRAM".

POOR CONNECTION



Properly connect the lighting system.



Check the condition of each of the lighting system's circuits.
Refer to "LIGHTING SYSTEM CHECK".

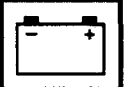

EB805020

LIGHTING SYSTEM CHECK

1.If the headlight fail to come on:

1. Bulb and bulb socket
 • Check the bulb and bulb socket for continuity.

NO CONTINUITY



Replace the bulb and/or bulb socket.

CONTINUITY



2. Voltage
 • Connect the pocket tester (DC 20 V) to the headlight couplers.

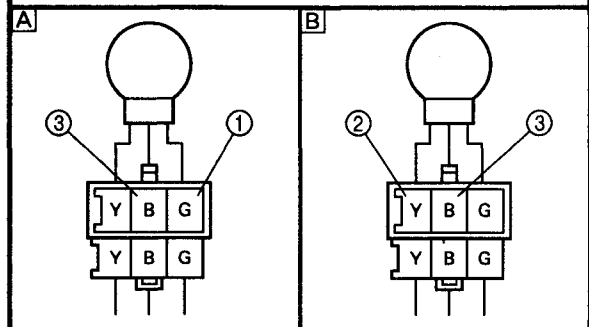

Tester (+) lead → **Green terminal ① or Yellow terminal ②**
Tester (-) lead → **Black terminal ③**

A When the lights switch is on "LO".
B When the lights switch is on "HI".

OUT OF SPECIFICATION



The wiring circuit from the main switch to the bulb socket connector is faulty, repair it.

• Turn the main switch to "ON".
 • Turn the lights switch to "LO" or "HI".
 • Check the voltage (12V) of the "Green" and "Yellow" leads on the bulb socket connector.

MEETS SPECIFICATION



This circuit is not faulty.

EB805021

2.If the meter light fails to come on:

1.Bulb and bulb socket
 ● Check the bulb and bulb socket for continuity.

CONTINUITY

2.Voltage
 ● Connect the pocket tester (20 V) to the bulb socket coupler.
Tester (+) lead → Blue terminal ①
Tester (-) lead → Black terminal ②

● Turn the main switch to "ON".
 ● Turn the lights switch to "LO" or "HI".
 ● Check the voltage (12V) of the "blue" lead on the bulb socket connector.

MEETS SPECIFICATION

This circuit is not faulty.

NO CONTINUITY

Replace the bulb and/or bulb socket.

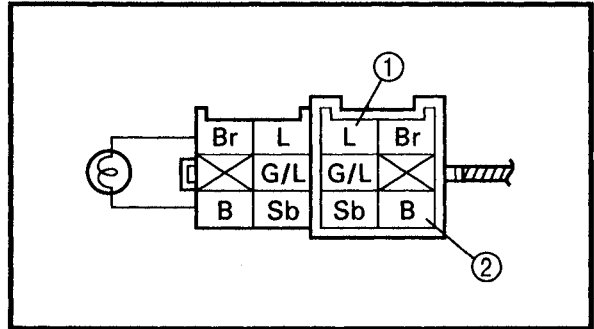

OUT OF SPECIFICATION

The wiring circuit from the main switch to the bulb socket connector is faulty, repair it.



EB806000

SIGNAL SYSTEM

CIRCUIT DIAGRAM

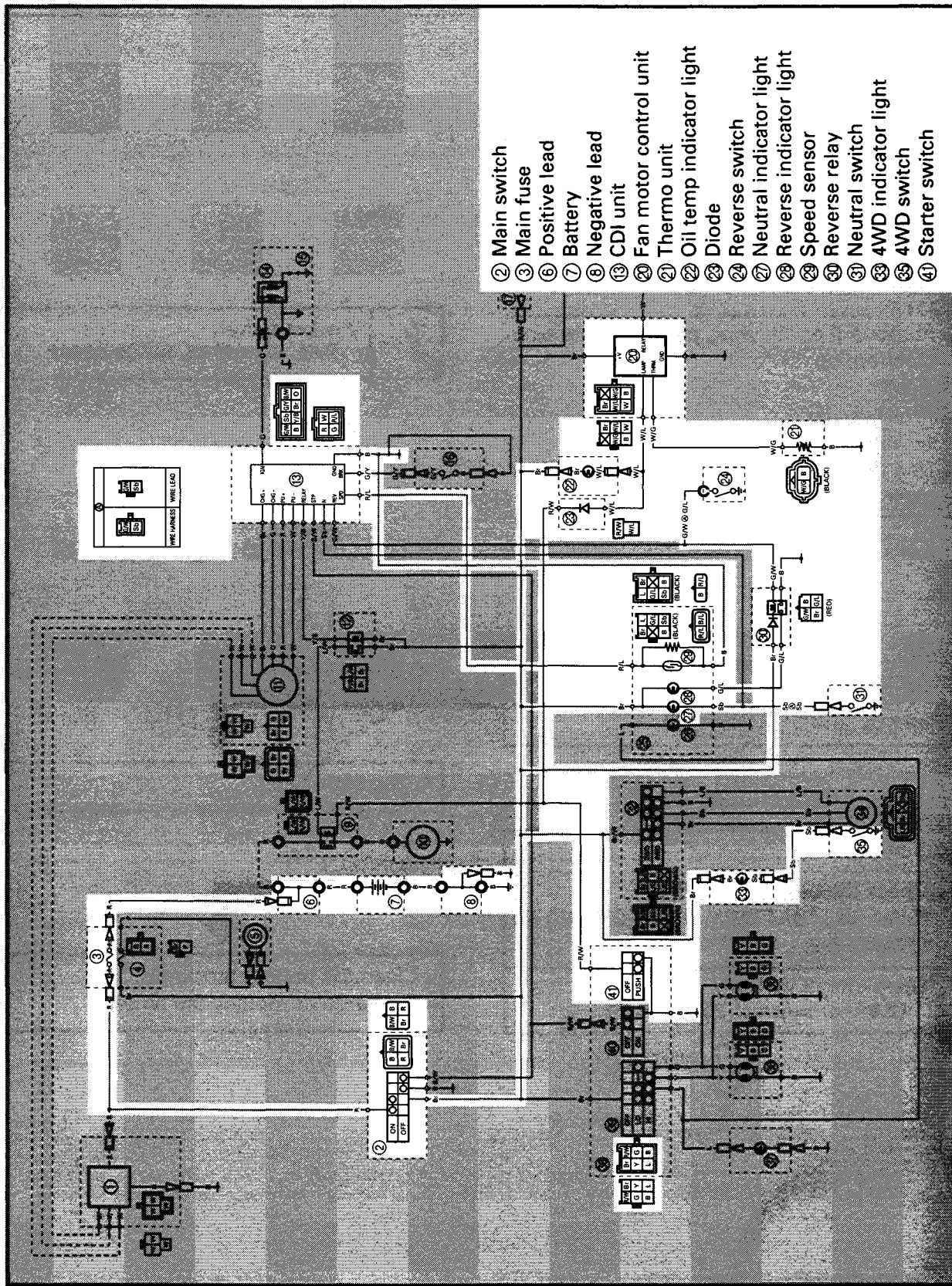

- ② Main switch
- ③ Main fuse
- ⑥ Positive lead
- ⑦ Battery
- ⑧ Negative lead
- ⑬ CDI unit
- ⑳ Fan motor control unit
- ㉑ Thermo unit
- ㉒ Oil temp indicator light
- ㉓ Diode
- ㉔ Reverse switch
- ㉖ Neutral indicator light
- ㉗ Reverse indicator light
- ㉘ Speed sensor
- ㉙ Reverse relay
- ㉚ Neutral switch
- ㉛ 4WD indicator light
- ㉜ 4WD switch
- ㉝ Starter switch

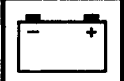

EB806010
TROUBLESHOOTING

IF THE INDICATOR LIGHT FAIL TO COME ON:

Procedure

Check:

- 1.Fuse (main)
- 2.Battery
- 3.Main switch
- 4.Wiring connections
(the entire signal system)

NOTE:

- Remove the following part(s) before troubleshooting:
 - 1)Seat
 - 2)Front carrier
 - 3)Front fender
- Use the following special tool(s) for troubleshooting.



Pocket tester:
P/N. YU-03112, 90890-03112

EB802011

1.Fuse (main)
Refer to "SWITCH INSPECTION".

CONTINUITY
↓

EB802012

2.Battery
• Check the battery condition.
Refer to "BATTERY INSPECTION" in CHAPTER 3.
Open-circuit voltage:
12.8 V or more at 20 °C (68 °F)

CORRECT
↓
*

NO CONTINUITY



Replace the fuse.

INCORRECT



- Clean the battery terminals.
- Recharge or replace the battery.



3. Main switch
Refer to "SWITCH INSPECTION".

INCORRECT



Replace main switch.



EB806011
4. Wiring connections
• Check the connections of the entire signal system.
Refer to "CIRCUIT DIAGRAM".

POOR CONNECTION



Properly connect the signal system.



Check the condition of each of the signal system's circuits.
Refer to "SIGNAL SYSTEM CHECK".



SIGNAL SYSTEM CHECK

EB806024

1.If the neutral indicator light fails to come on:

1.Bulb and bulb socket
 • Check the bulb and bulb socket for continuity.

CONTINUITY

NO CONTINUITY

Replace the bulb and/or bulb socket.

2.Neutral switch
 Refer to "SWITCH INSPECTION".

CONTINUITY

NO CONTINUITY

Replace the neutral switch.

3.Voltage
 • Connect the pocket tester (DC 20 V) to the bulb socket coupler.
Tester (+) lead → Brown terminal ①
Tester (-) lead → Sky blue terminal ②

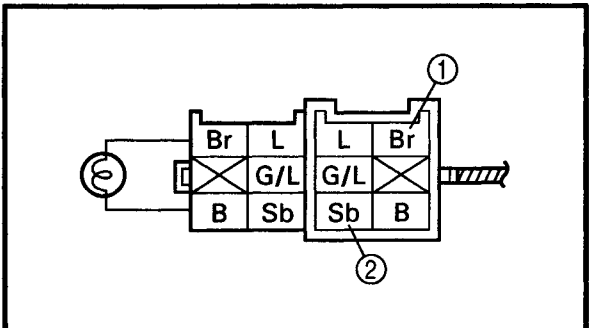

• Turn the main switch to "ON".
 • Check the voltage (12 V).

MEETS SPECIFICATION

OUT OF SPECIFICATION

This circuit is not faulty.

The wiring circuit from the main switch to the bulb socket connector is faulty, repair it.



2.If the reverse indicator light fails to come on:

1.Bulb and bulb socket
 • Check the bulb and bulb socket for continuity.

CONTINUITY

NO CONTINUITY

Replace the bulb and/or bulb socket.

2.Reverse switch
 Refer to "SWITCH INSPECTION".

CONTINUITY

NO CONTINUITY

Replace the reverse switch.

3.Reverse relay
 • Remove the reverse relay from the wire harness.
 • Connect the pocket tester ($\Omega \times 1$) and battery (12 V) to the reverse relay terminals.

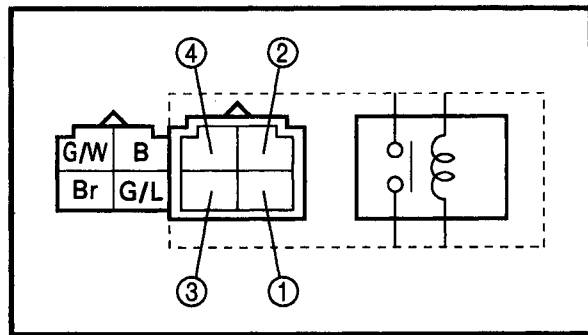

Battery (+) terminal → Brown terminal ①
Battery (-) terminal → Green/White terminal ②
Tester (+) lead → Green/Blue terminal ③
Tester (-) lead → Black terminal ④
 • Check the reverse relay for continuity.

CONTINUITY

Replace reverse relay.

NO CONTINUITY

4.Voltage
 • Connect the pocket tester (DC 20 V) to the bulb socket coupler.
Tester (+) lead → Brown terminal ①
Tester (-) lead → Green/Blue terminal ②

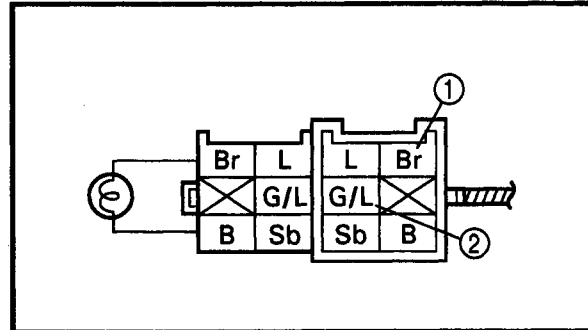

- Turn the main switch to "ON".
- Check for voltage (12 V).

↓ MEETS SPECIFICATION

This circuit is not faulty.

OUT OF SPECIFICATION

The wiring circuit from the main switch to the bulb socket connector is faulty, repair it.

3.Oil temp warning light does not come on when the start switch is pushed on, or oil temp warning light does not come on when temperature is high (more than 147.5 ~ 162.5°C (297.5 ~ 324.5°F)).

- 1.Bulb and bulb socket
- Check the bulb and bulb socket for continuity.

↓ CONTINUITY

NO CONTINUITY

Replace bulb and/or bulb socket.

- 2.Thermo unit
- Remove the thermo unit from the crankcase.
 - Connect the pocket tester ($\Omega \times 10$) to the thermo unit ①.
 - Immerse the thermo unit in the engine oil ②.
 - Measure the resistance.



Thermo unit resistance:
 150 °C (302 °F): 307 ~ 339 Ω
 220 °C (428 °F): 209 ~ 231 Ω

⚠ WARNING

Handle the thermo unit with special care.
 Never subject it to a strong shock or allow it to be dropped. Should it be dropped, it must be replaced.



Thermo unit:
 20 Nm (2.0 m · kg, 14 ft · lb)
 Three bond sealock® #10

↓ GOOD CONDITION
 *

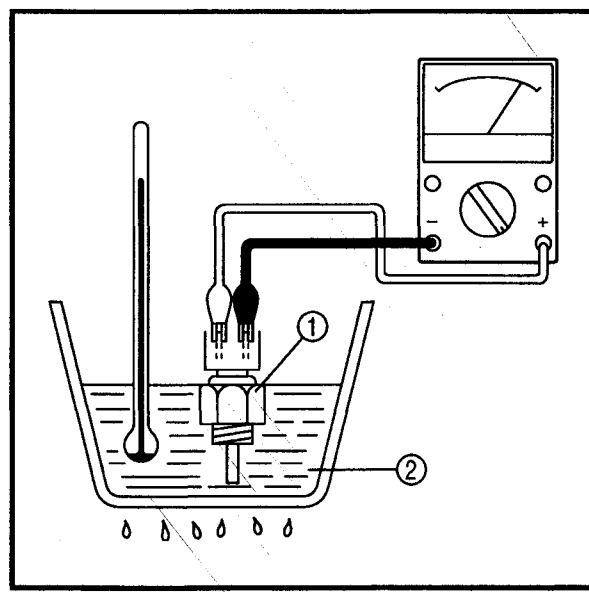

BAD CONDITION

Replace the thermo unit.



3.Voltage

- Connect the pocket tester (DC 20 V) to the bulb socket connector.

Tester (+) lead → Brown lead ①
Tester (-) lead → Frame ground

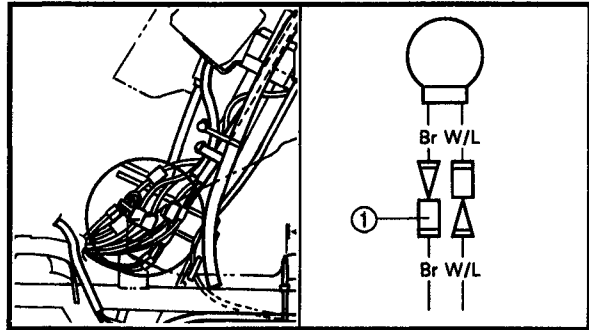

- Turn the main switch to "ON".
- Check for voltage (12 V).



OUT OF SPECIFICATION



The wiring circuit from the main switch to the bulb socket connector is faulty, repair it.

4.Diode

- Remove the diode from wire harness.
- Check for continuity as follows:
 Red/White ① – White/Blue ②

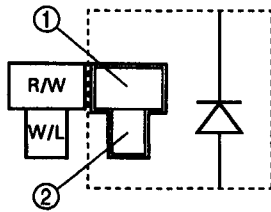

Red/White ① → White/Blue ②	Continuity
White/Blue ② → Red/White ①	No continuity



INCORRECT



Replace diode.

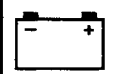

5. Start switch
Refer to "SWITCH INSPECTION".

INCORRECT

Replace handlebar switch (left).

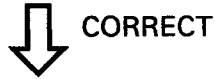

Replace the fan motor control unit.

EB806024

1. If the 4WD indicator light fails to come on:

1. Bulb and bulb socket
• Check the bulb and bulb socket for continuity.

NO CONTINUITY

Replace the bulb and/or bulb socket.



2. 4WD switch
Refer to "SWITCH INSPECTION".

NO CONTINUITY

Replace the 4WD switch.



3. Voltage
• Connect the pocket tester (DC 20 V) to the bulb socket lead.
Tester (+) lead → **Brown terminal ①**
Tester (-) lead → **Sky blue terminal ②**

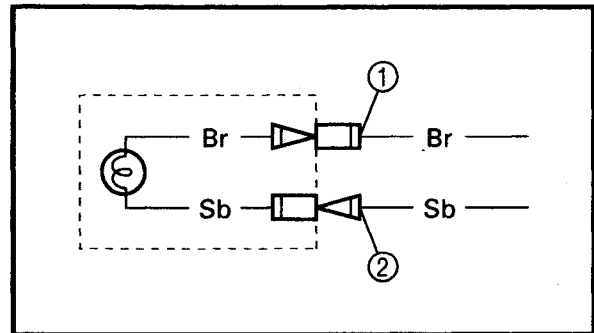

• Turn the main switch to "ON".
• Check the voltage (12 V).

OUT OF SPECIFICATION

The wiring circuit from the main switch to the bulb socket connector is faulty, repair it.



This circuit is not faulty.

COOLING SYSTEM
CIRCUIT DIAGRAM

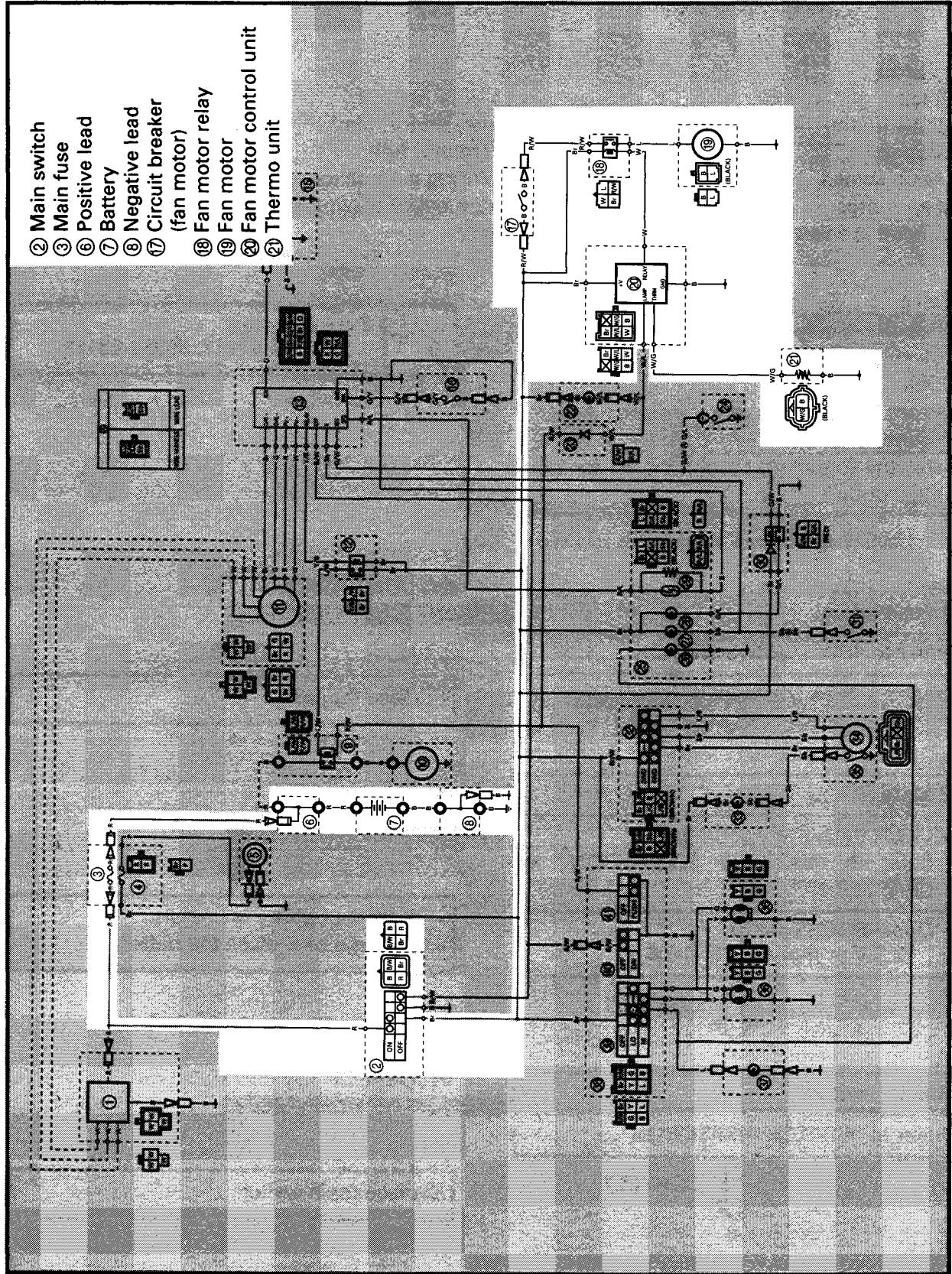

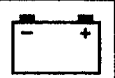

TROUBLESHOOTING

IF THE FAN MOTOR DOES NOT MOVE:

Procedure

Check:

- | | |
|-------------------------------|-----------------------------|
| 1.Fuse (main) | 6.Fan motor relay |
| 2.Battery | 7.Thermo unit |
| 3.Main switch | 8.Wiring connection |
| 4.Fan motor | (the entire cooling system) |
| 5.Circuit breaker (fan motor) | |

NOTE:

- Remove the following part(s) before troubleshooting.
 - 1)Seat
 - 2)Front carrier
 - 3)Front fender
- Use the following special tool(s) for troubleshooting.

	Pocket tester: P/N. YU-03112, 90890-03112
--	---

EB802011

1.Fuse (main)
Refer to "SWITCH INSPECTION".

CONTINUITY

NO CONTINUITY

Replace the fuse.

EB802012

2.Battery
 • Check the battery condition.
 Refer to "BATTERY INSPECTION" in CHAPTER 3.
Open-circuit voltage:
 12.8 V or more at 20 °C (68 °F)

CORRECT

INCORRECT

- Clean the battery terminals.
- Recharge or replace the battery.

3.Main switch
Refer to "SWITCH INSPECTION".

CORRECT
*

INCORRECT

Replace main switch.



4. Fan motor

- Disconnect the fan motor coupler.
- Connect the battery (12 V) as shown.

Battery (+) lead → Blue terminal ①
Battery (-) lead → Black terminal ②

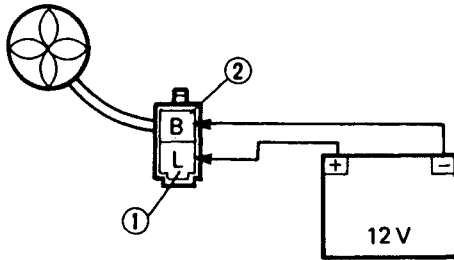

- Check the operation of the fan motor.

DOES NOT MOVES

Replace the fan motor.

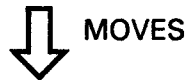

5. Circuit breaker (fan motor)

- Remove the circuit breaker from the wire harness.
- Connect the pocket tester ($\Omega \times 1$) to the circuit breaker.

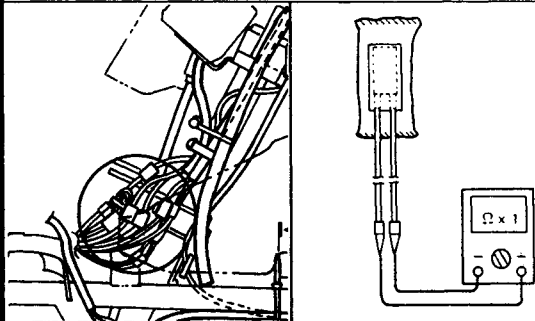

Circuit breaker resistance:
Zero Ω at 20 °C (68 °F)

OUT OF SPECIFICATION

Replace the circuit breaker.

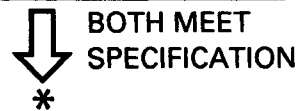

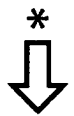

6. Fan motor relay

- Remove the fan motor relay from the wire harness.
- Connect the pocket tester ($\Omega \times 1$) and the battery (12 V) to the fan motor relay terminals.

Battery (+) terminal → **Brown terminal** ①
Battery (-) terminal → **White terminal** ②

Tester (+) lead → **Red/White terminal** ③
Tester (-) lead → **Blue terminal** ④

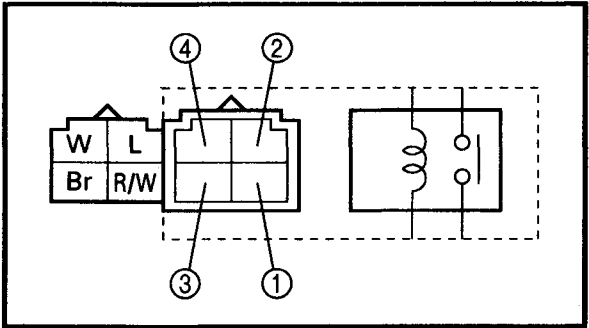

- Check the fan motor relay for continuity.



Replace the fan motor relay.

7. Thermo unit

- Remove the thermo unit from the crankcase.
- Connect the pocket tester ($\Omega \times 10$) to the thermo unit ①.
- Immerse the thermo unit in the engine oil ②.
- Measure the resistance.

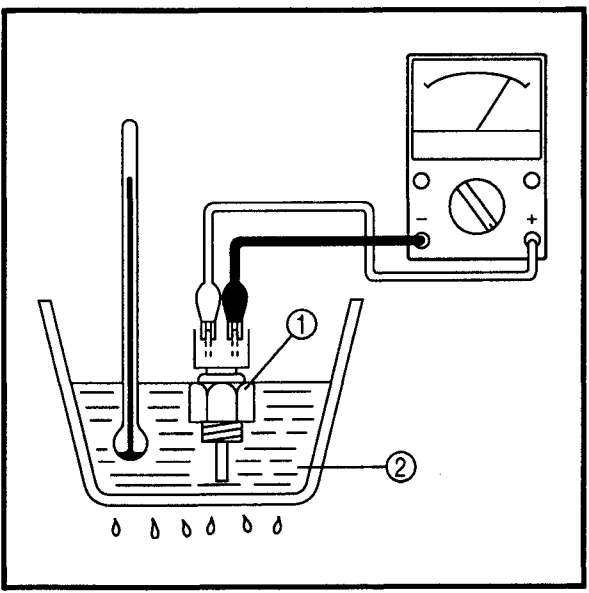

Thermo unit resistance:
 150 °C (302 °F): 307 ~ 339 Ω
 220 °C (428 °F): 209 ~ 231 Ω

⚠ WARNING

Handle the thermo unit with special care.
 Never subject it to strong shock or allow it to be dropped. Should it be dropped, it must be replaced.

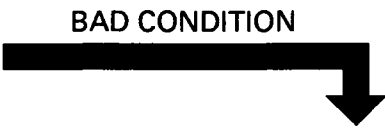

Replace the thermo unit.

Thermo unit:
 20 Nm (2.0 m · kg, 14 ft · lb)
 Three bond sealock® #10

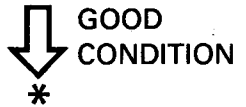



EB803028

8.Wiring connection
• Check the connections of the entire starting system.
Refer to "CIRCUIT DIAGRAM".

POOR CONNECTION



Properly connect the cooling system.



CORRECT

Replace the fan motor control unit.

2WD/4WD SELECTING SYSTEM
CIRCUIT DIAGRAM

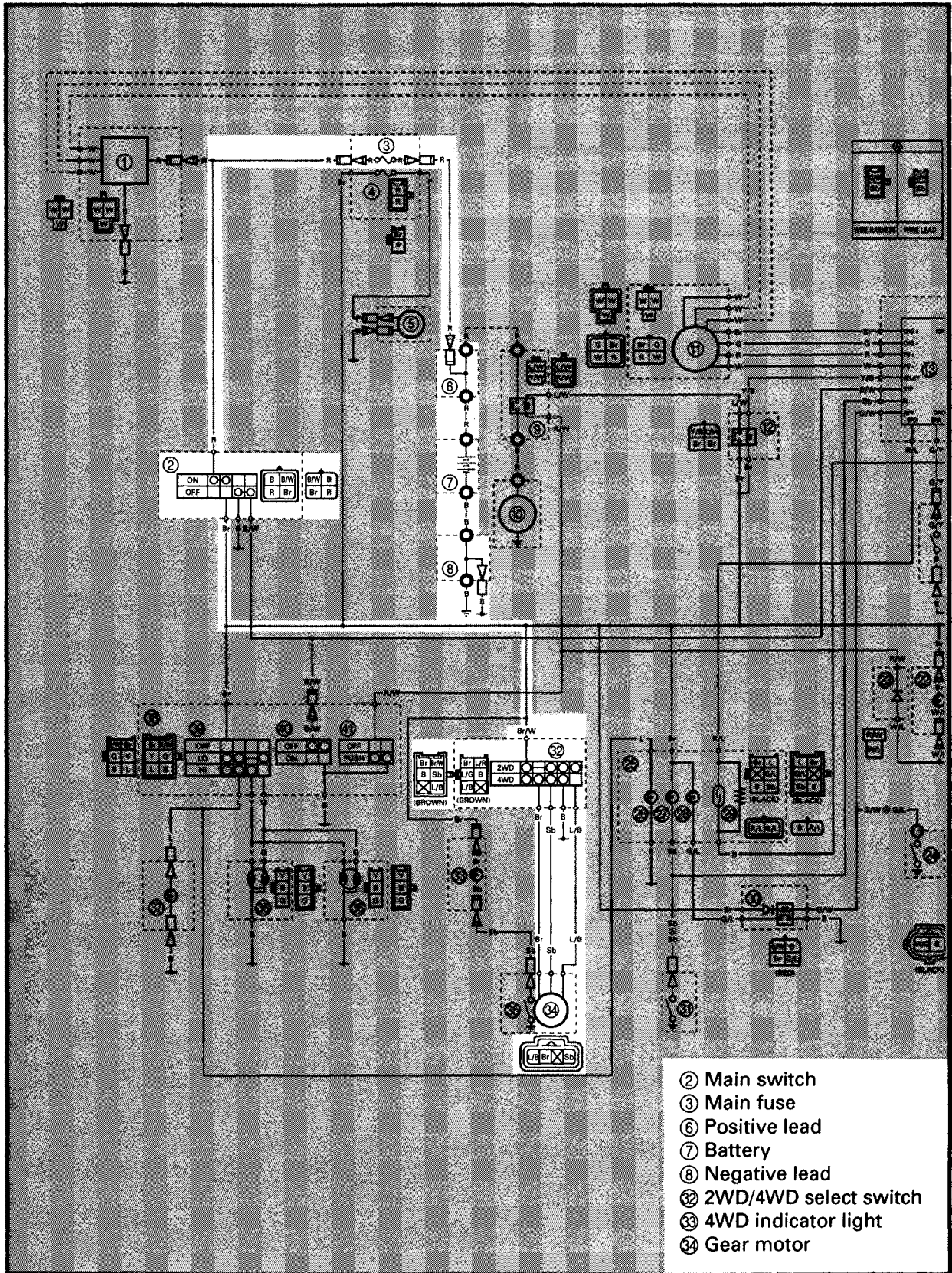



EB803020

TROUBLESHOOTING

IF THE 4WD INDICATOR LIGHT FAIL TO COME ON:

Procedure

Check:

- | | |
|---|--|
| <ol style="list-style-type: none"> 1.Fuse (main) 2.Battery 3.Main switch 4.2WD/4WD selecting switch | <ol style="list-style-type: none"> 5.Gear motor 6.Wiring connections
(the entire 2WD/4WD selecting system) |
|---|--|

NOTE:

- Remove the following part(s) before troubleshooting:
 - 1)Seat
 - 2)Front carrier
 - 3)Front fender
- Use the following special tool(s) for troubleshooting.

Pocket tester:
P/N. YU-03112, 90890-03112

EB802011

1.Fuse (main)
Refer to "SWITCH INSPECTION".

↓ CONTINUITY

EB802012

2.Battery

- Check the battery condition.
Refer to "BATTERY INSPECTION" in CHAPTER 3.

Open-circuit voltage:
12.8 V or more at 20 °C (68 °F)

↓ CORRECT

3.Main switch
Refer to "SWITCH INSPECTION".

↓ CORRECT
*

NO CONTINUITY

↓

Replace the fuse.

INCORRECT

↓

- Clean the battery terminals,
- Recharge or replace the battery.

INCORRECT

↓

- Replace main switch.



4.2WD/4WD select switch
Refer to "SWITCH INSPECTION".



INCORRECT



Replace 2WD/4WD select switch.

5. Gear motor

- Check that the shift fork sliding gear is in the 2WD position.
- Disconnect the gear motor coupler.
- Remove the gear motor from the differential gear case.
- Connect the battery (12 V) to the gear motor terminals.

2WD → 4WD:
 Battery (+) terminal → Brown terminal ①
 Battery (-) terminal → Sky blue terminal ②

4WD → 2WD:
 Battery (+) terminal → Sky blue terminal ②
 Battery (-) terminal → Blue/Black terminal ③

- Make sure that the drive gear (shift fork sliding gear) operates correctly.

NOTE: _____
 When installing the differential gear case in the gear motor, refer to CHAPTER 1 "FEATURES".



INCORRECT

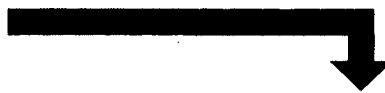

- Replace the gear motor.

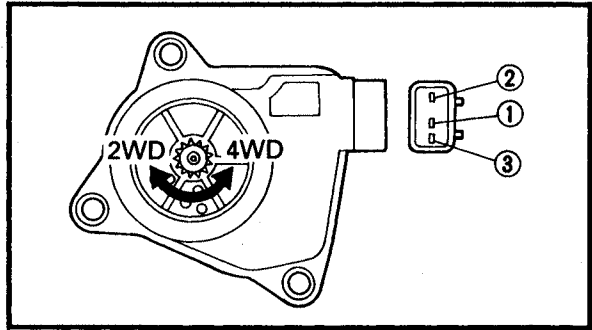

EB803028

6. Wiring connection

- Check the connections of the entire 2WD/4WD selecting system. Refer to "CIRCUIT DIAGRAM".

POOR CONNECTION



Properly connect the 2WD/4WD selecting system.

TROUBLESHOOTING

NOTE:

The following troubleshooting does not cover all the possible causes of trouble. It should be helpful, however, as a guide to troubleshooting. Refer to the relative procedure in this manual for inspection, adjustment and replacement of parts.

STARTING FAILURE/HARD STARTING**FUEL SYSTEM****Fuel tank**

- Empty
- Clogged fuel filter
- Clogged fuel strainer
- Clogged fuel breather hose
- Deteriorated or contaminated fuel

Fuel cock

- Clogged fuel hose

Carburetor

- Deteriorated or contaminated fuel
- Clogged pilot jet
- Clogged pilot air passage
- Sucked-in air
- Deformed float
- Worn needle valve
- Improperly sealed valve seat
- Improperly adjusted fuel level
- Improperly set pilot jet
- Clogged starter jet
- Starter plunger malfunction

Air filter

- Clogged air filter element

ELECTRICAL SYSTEM**Spark plug**

- Improper plug gap
- Worn electrodes
- Wire between terminals broken
- Improper heat range
- Faulty spark plug cap

Ignition coil

- Broken or shorted primary/secondary
- Faulty spark plug lead
- Broken body

CDI system

- Faulty CDI unit
- Faulty pickup coil
- Faulty source coil
- Broken woodruff key

Switches and wiring

- Faulty main switch
- Faulty engine stop switch
- Broken or shorted wiring
- Faulty neutral switch
- Faulty start switch
- Faulty rear brake switch

Starter motor

- Faulty starter motor
- Faulty starter relay
- Faulty starter circuit cut-off relay
- Faulty starter clutch

COMPRESSION SYSTEM

Cylinder and cylinder head

- Loose spark plug
- Loose cylinder head or cylinder
- Broken cylinder head gasket
- Worn, damaged or seized cylinder

Piston and piston rings

- Improperly installed piston ring
- Worn, fatigued or broken piston ring
- Seized piston ring
- Seized or damaged piston

Valve, camshaft and crankshaft

- Improperly sealed valve
- Improperly contacted valve and valve seat
- Improper valve timing
- Broken valve spring
- Seized camshaft
- Seized crankshaft

POOR IDLE SPEED PERFORMANCE

POOR IDLE SPEED PERFORMANCE

Carburetor

- Improperly returned starter plunger
- Loose pilot jet
- Clogged pilot jet
- Clogged pilot air jet
- Improperly adjusted idle speed (Throttle stop screw)
- Improper throttle cable play
- Flooded carburetor

Electrical system

- Faulty spark plug
- Faulty CDI unit
- Faulty pickup coil
- Faulty source coil
- Faulty ignition coil

Valve train

- Improperly adjusted valve clearance

Air filter

- Clogged air filter element

POOR MEDIUM AND HIGH SPEED PERFORMANCE

POOR MEDIUM AND HIGH SPEED PERFORMANCE

Refer to "STARTING FAILURE/HARD STARTING" and "POOR IDLE SPEED PERFORMANCE-valve train".

Carburetor

- Improper jet needle clip position
- Improperly adjusted fuel level
- Clogged or loose main jet
- Deteriorated or contaminated fuel

Air filter

- Clogged air filter element

FAULTY DRIVE TRAIN

The following conditions may indicate damaged shaft drive components:

Symptoms	Possible Causes
1.A pronounced hesitation or "jerky" movement during acceleration, deceleration, or sustained speed. (This must not be confused with engine surging or transmission characteristics.) 2.A "rolling rumble" noticeable at low speed; a high-pitched whine; a "clunk" from a shaft drive component or area. 3.A locked-up condition of the shaft drive mechanism, no power transmitted from the engine to the front and/or rear wheels.	A.Bearing damage. B.Improper gear lash. C.Gear tooth damage. D.Broken drive shaft. E.Broken gear teeth. F.Seizure due to lack of lubrication. G.Small foreign objects lodged between the moving parts.

NOTE:

Areas A, B, and C above may be extremely difficult to diagnose. The symptoms are quite subtle and difficult to distinguish from normal machine operating noise. If there is reason to believe these components are damaged, remove the components and inspect them.

FAULTY GEAR SHIFTING

HARD SHIFTING

Refer to "CLUTCH SLIPPING/Dragging-CLUTCH DRAGGING".

SHIFT LEVER DOES NOT MOVE

Shift cam, shift fork

- Groove jammed with impurities
- Seized shift fork
- Bent shift fork guide bar

Transmission

- Seized transmission gear
- Jammed impurities
- Incorrectly assembled transmission

Shift guide

- Broken shift guide

JUMPS-OUT-OF GEAR

Shift fork

- Worn shift fork

Shift cam

- Improper thrust play
- Worn shift cam groove

Transmission

- Worn gear dog

FAULTY CLUTCH PERFORMANCE

ENGINE OPERATES BUT SCOOTER WILL NOT MOVE

V-belt

- Bent, damaged or worn V-belt
- V-belt slips

Primary pulley cam and primary pulley slider

- Damaged or worn primary pulley cam
- Damaged or worn primary pulley slider

Transmission

- Damaged transmission gears

CLUTCH SLIPPING

Clutch spring

- Damaged, loosen or worn clutch shoe spring

Clutch shoe

- Damaged or worn clutch shoe

Primary sliding sheave

- Seized primary sliding sheave

POOR STARTING PERFORMANCE

V-belt

- V-belt slips
- Oil or grease in on the V-belt

Primary sliding sheave

- Faulty operation
- Worn pin groove
- Worn pin

Clutch shoe

- Bent, damaged or worn clutch shoe

POOR SPEED PERFORMANCE

V-belt

- Oil or grease is on the V-belt

Primary pulley weight

- Faulty operation
- Worn primary pulley weight

Primary fixed sheave

- Worn primary fixed sheave

Primary sliding sheave

- Worn primary sliding sheave

Secondary fixed sheave

- Worn secondary fixed sheave

Secondary sliding sheave

- Worn secondary sliding sheave

OVERHEATING

OVERHEATING

Ignition system

- Improper spark plug gap
- Improper spark plug heat range
- Faulty CDI unit

Fuel system

- Improper carburetor main jet (improper setting)
- Improper fuel level
- Clogged air filter element

Compression system

- Heavy carbon build-up

Engine oil

- Improper oil level
- Improper oil viscosity
- Inferior oil quality

Brake

- Brake drag

Oil cooling system

- Clogged or damaged oil cooler

FAULTY BRAKE

POOR BRAKING EFFECT

Front disc brake

- Worn brake pads
- Worn disc
- Air in brake fluid
- Leaking brake fluid
- Faulty master cylinder kit cup
- Faulty caliper kit seal
- Loose union bolt
- Broken brake hose and pipe
- Oily or greasy disc/brake pads
- Improper brake fluid level

Rear drum brake

- Worn brake shoe lining
- Worn brake drum
- Oily or greasy brake shoe lining
- Oily or greasy brake drum
- Improperly adjusted brake free play
- Improper brake cam lever position
- Fatigue/damaged return spring

SHOCK ABSORBER MALFUNCTION

MALFUNCTION

- Bent or damaged damper rod
- Damaged oil seal lip
- Fatigued shock absorber spring

UNSTABLE HANDLING

UNSTABLE HANDLING

Handlebar

- Improperly installed or bent

Steering

- Incorrect toe-in
- Bent steering stem
- Improperly installed steering stem
- Damaged bearing or bearing race
- Bent tie-rods
- Deformed steering knuckles

Tires

- Uneven tire pressures on both sides
- Incorrect tire pressure
- Uneven tire wear

Wheels

- Deformed wheel
- Loose bearing
- Bent or loose wheel axle
- Excessive wheel run-out

Frame

- Bent
- Damaged frame

Swingarm

- Worn bearing or bushing
- Bent or damaged

LIGHTING SYSTEM

HEADLIGHT DARK

- Improper bulb
- Too many electric accessories
- Hard charging (broken stator coil and/or faulty rectifier/regulator)
- Incorrect connection
- Improperly grounded
- Poor contacts (main or lights switch)
- Bulb life expired

BULB BURNT OUT

- Improper bulb
- Faulty battery
- Faulty rectifier/regulator
- Improperly grounded
- Faulty main and/or lights switch
- Bulb life expired

PROTECT YOUR INVESTMENT
Use Genuine YAMAHA Parts And Accessories



LIT-11616-FW-00

YAMAHA MOTOR CORPORATION, U.S.A.
PRINTED IN U.S.A.